

# Platinum™ 16

## User's Guide



**KEEPING THE WORLD SEWING™**

# **Congratulations on your purchase of the PLATINUM™ I6 quilting machine by HUSQVARNA VIKING®**

*Welcome to the HUSQVARNA VIKING® family!*

HUSQVARNA VIKING® is committed to your quilting success through excellence in customer service and education. With that in mind, we invite you to visit our website at [www.husqvarnaviking.com](http://www.husqvarnaviking.com) to learn more about the art of quilting through classes and events held around the world. Plus, you will find tips, tricks and inspiration on a variety of quilting topics including the basics of setting up your machine and loading a quilt.

We invite you to share your projects with us on our Facebook and Pinterest pages as well. Your new quilting friends are already there and they can't wait to see your creations!

Remember, if you ever have questions, your local retailer can help you or you can contact us by using the contact information provided on the website for your country.

Thank you and happy quilting!

# IMPORTANT INFORMATION: REGULATIONS

## Federal Communications Commissions (FCC) Declaration of Conformity (For USA Only)

Responsible Party: SVP Worldwide  
1224 Heil Quaker Blvd  
LaVergne, TN 37086 USA

declares that the product

Product Name: PLATINUM™ 16

complies with Part 15 of the FCC Rules. Operation is subject to the following two conditions: (1) this device may not cause harmful interference, and (2) this device must accept any interference received, including interference that may cause undesired operation.

This equipment has been tested and found to comply with the limits for Class B digital device, pursuant to Part 15 of the FCC Rules. These limits are designed to provide reasonable protection against harmful interference in a residential installation. This equipment generates, uses, and can radiate radio frequency energy and, if not installed and used in accordance with the instructions, may cause harmful interference to radio communications. However, there is no guarantee that interference will not occur in a particular installation. If this equipment does cause harmful interference to radio or television reception, which can be determined by turning the equipment off and on, the user is encouraged to try to correct the interference by one or more of the following measures:

- Reorient or relocate the receiving antenna.
- Increase the separation between the equipment and receiver.
- Consult the dealer or an experienced radio/TV technician for help.
- Changes or modifications not expressly approved by the manufacturer or local sales distributor could void the user's authority to operate the equipment.

---

## Canadian Department of Communications Compliance Statement (For Canada Only)

This digital apparatus does not exceed the Class B limits for radio noise emission from digital apparatus as set out in the interference-causing equipment standard entitled "Digital Apparatus", ICES-003 of the Department of Communications.

---

## Radio Interference (Other than USA and Canada)

This machine complies with EN55022 (CISPR Publication 22) /Class B and AUS/NZ 55022/Class B.

---

## Quick Facts

The PLATINUM™ 16 quilting machine utilizes high-tech electronics and an innovative touch-screen user interface to offer greater functionality and ease of operation to home quilters than ever before conceived in the quilting industry. The PLATINUM™ 16 quilting machine is a high quality machine that incorporates very robust design features and is very easy to service.

# IMPORTANT SAFETY INSTRUCTIONS

## ***Read all instructions before using.***

When using this machine, basic safety precautions should always be taken, including the following:

## **DANGER - To reduce the risk of electric shock:**

- A quilting machine should never be left unattended when plugged in. Always unplug the machine from the electrical outlet immediately after using and before cleaning.

## **WARNING - To reduce the risk of burns, fire, electric shock, or injury to persons:**

- Do not allow to be used as a toy. Close attention is necessary when this quilting machine is used by or near children.
- Use this quilting machine only for its intended use as described in this manual. Use only attachments recommended by the manufacturer as contained in this manual.
- Never operate this quilting machine if it has a damaged cord or plug, if it is not working properly, if it has been dropped or damaged, or dropped into water. Return the quilting machine to the nearest authorized dealer or service center for examination, repair, electrical or mechanical adjustment.
- Never operate the machine with any air openings blocked. Keep ventilation openings of the machine free from the accumulation of lint, dust, and loose cloth.
- Never drop or insert any object into any opening.
- Do not use outdoors.
- Do not operate where aerosol (spray) products are being used or where oxygen is being administered.
- To disconnect, turn the machine switch to the symbol "O" position which represents off, then remove plug from outlet.
- Do not unplug by pulling on cord. To unplug, grasp the plug, not the cord.
- Keep fingers away from all moving parts. Special care is required around the machine needle.
- Always use the proper needle plate. The wrong plate can cause the needle to break.
- Do not use bent needles.
- Switch the machine to the symbol "O" position to turn it off when making any adjustments in the needle area, such as threading needle, changing needle, threading bobbin, or changing presser foot, and the like.
- Always unplug the machine from the electrical outlet when removing covers, lubricating, or when making any other user servicing adjustments mentioned in the instruction manual.
- This sewing machine is not intended for use by young children or infirm persons without supervision. (For Australia and New Zealand only)
- Young children should be supervised to ensure that they do not play with this machine.

## **SAVE THESE INSTRUCTIONS**

***This machine is intended for household and commercial use.***

### ***Disclaimer***

SVP Worldwide and its Representatives are in no way legally responsible or liable for damage to the PLATINUM™ 16 quilting machine when used improperly or not in accordance with the guidelines stated in this manual or when used on machine quilting frames not recommended by SVP Worldwide.

# HOW TO UNPACK/REPACK THE MACHINE

Keep the carton and packing materials. You will need them in the event that you need to return the machine to the dealer or send it for repair. If you do not pack the machine properly or if you do not use the correct packaging materials, the machine could be damaged. SVP Worldwide is not liable for damage that occurs during return shipping. Follow the diagram below to unpack and repack the machine.

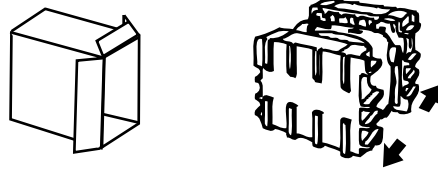

## IMPORTANT

These packaging materials are designed to prevent the machine from being damaged. Keep them in case you need to bring this machine to the dealer or send it for repair.

## PLEASE READ THESE INSTRUCTIONS BEFORE USING THE MACHINE.

### To use the machine safely

1. Carefully watch the needle when sewing. Do not touch the hand wheel, take up lever, needle or other moving parts.
2. Turn the machine off and unplug the cord in the following cases
  - when you have stopped using the machine;
  - when you replace or remove the needle or any other part;
  - in case of failure when you use the machine;
  - when you check or clean the machine;
  - when you leave the machine unattended.
3. Connect the machine directly to the wall outlet. Do not use extension cords.

### To increase the life of your machine

1. Do not store this machine in areas exposed to direct sunlight or high humidity. Never use or store the machine near a heater, an iron, a halogen lamp or other hot things.
2. Use only neutral soaps or detergents to clean the machine. Benzene, solvents and scouring powders can damage the case and the machine and therefore should never be used.
3. Do not drop or bump the machine.
4. Always consult the manual to replace or fix the presser foot, needle or any other part of the machine.

### To repair or adjust the machine

If the machine breaks down or needs adjustment, first check the troubleshooting chart in the appendix to inspect and adjust the machine yourself.

**For more product information and updates, visit our website at [www.husqvarnaviking.com](http://www.husqvarnaviking.com).**

**We reserve the right to change the machine equipment and the assortment of accessories without prior notice, or make modifications to the performance or design.**

**Such modifications, however, will always be to the benefit of the user and the product.**

## FOR USERS IN THE UK, EIRE, MALTA AND CYPRUS ONLY

If this machine is fitted with a three-pin non-rewireable BS plug then please read the following.

### IMPORTANT

If the available socket outlet is not suitable for the plug supplied with this equipment, it should be cut off and an appropriate three pin plug fitted. With alternative plugs an approved fuse must be fitted in the plug.

**NOTE:** The plug severed from the main leads must be destroyed as a plug with bared flexible cords is hazardous if engaged in a live socket outlet. In the event of replacing the plug fuse, use a fuse approved by ASTA to BS 1362, i.e. carrying the mark, rating as marked on plug.

Always replace the fuse cover. Never use plugs with the fuse cover omitted.

**WARNING: DO NOT CONNECT EITHER WIRE TO THE EARTH TERMINAL WHICH IS MARKED WITH THE LETTER 'E', BY THE EARTH SYMBOL OR COLOURED GREEN OR GREEN AND YELLOW.**

The wires in this main lead are coloured in accordance with the following code:

Blue	Neutral
Brown	Live

As the colours of the wiring in the main lead of this appliance may not correspond with the coloured markings identifying the terminals in your plug, proceed as follows:

The wire which is coloured blue must be connected to the terminal which is marked with the letter 'N' or coloured black or blue.

The wire which is coloured brown must be connected to the terminal which is marked with the letter 'L' or coloured red or brown.

# GROUNDING

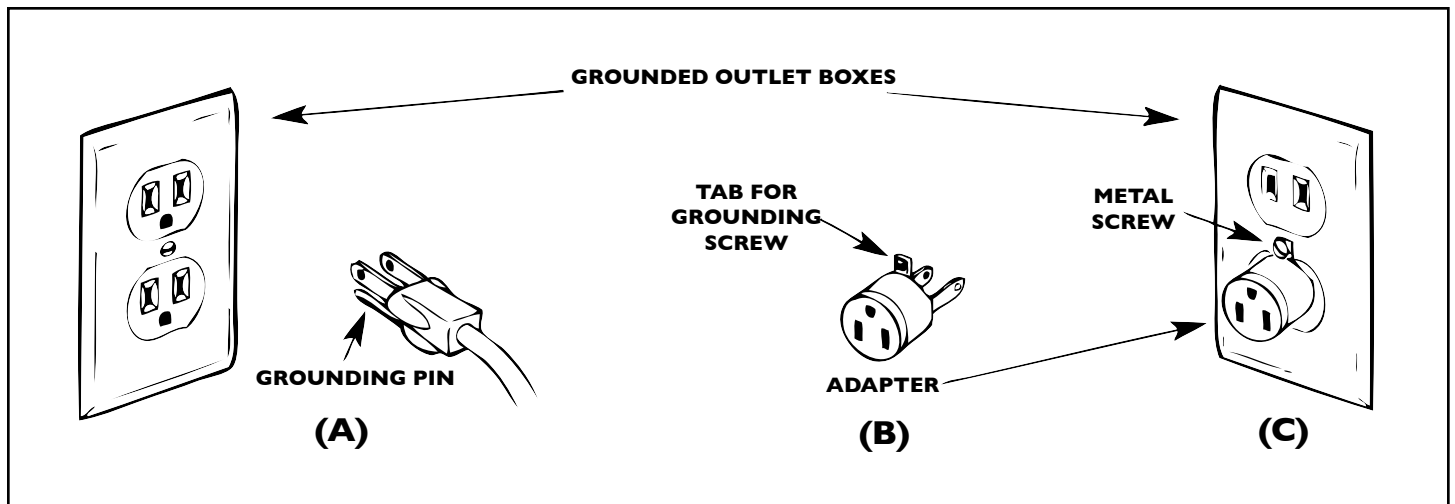

*Figure 1*

This product is for use on a nominal 120 V or nominal 220 V circuit, and has a grounding plug that looks like the plug illustrated in sketch A in Figure 1. A temporary adapter, which looks like the adapter illustrated in sketches B and C, may be used to connect this plug to a 2-pole receptacle as shown in sketch B if a properly grounded outlet is not available. The temporary adapter should be used only until a properly grounded outlet can be installed by a qualified electrician. The green colored rigid ear, lug, and the like, extending from the adapter must be connected to a permanent ground such as a properly grounded outlet box cover. Whenever the adapter is used, it must be held in place by the metal screw.

**Note:** In Canada, the use of a temporary adapter is not permitted by the Canadian Electric Code.

# Table of Contents

9	Safety Section Quick Facts
10	Components (Front Side View)
11	Components (Back Side View)
12	Components (Rear and Front Views) Included Accessories
13	Setting Up the Table Placing Machine in Table Installing Power Cord Installing Foot Pedal
14	Installing Thread Stand Installing Color Touch-Screen
15	Inserting Needle Needle/Thread Selection Guide Adjusting Hopping Foot
16	Threading the Machine
18	Bobbin Case and Bobbin Thread Tension Adjustments
19	Top Thread Tension Adjustment
20	Maintenance
21	Using the Touch-Screen Displays
28	Getting Started Quilting
29	Correcting Common Issues
32	Optional Accessories
33	Register your PLATINUM™ 16 Quilting Machine



## Safety Section

This device complies with Part 15 of the FCC Rules. Operation is subject to the following two conditions:  
(1) This device may not cause harmful interference, and  
(2) this device must accept any interference received, including interference that may cause undesired operation.

**Please note:** Do not operate your PLATINUM™ 16 quilting machine until you have completely read the information contained in this manual. Please keep all packaging and order information for warranty purposes.

1. The PLATINUM™ 16 quilting machine is very heavy. Never attempt to lift it alone – always use two people when lifting.
2. Always unplug the PLATINUM™ 16 quilting machine from the electrical outlet when performing any maintenance, changing the needle, removing thread locks, or when left unattended.
3. Keep fingers away from all moving parts. Use caution around the needle or sharp external components.
4. Change the needle often. Do not use bent or dull needles. “Every quilt deserves a new needle”.
5. Switch the power off when making any adjustments in the needle or bobbin area, such as threading the needle, installing the bobbin case, or when oiling or cleaning.
6. Never drop or insert foreign objects into any opening.
7. The PLATINUM™ 16 quilting machine should only be used indoors away from moisture.
8. The PLATINUM™ 16 quilting machine should not be stored or used in extreme temperatures.
9. Use the PLATINUM™ 16 quilting machine only for its intended use as described in this manual.
10. Use only attachments recommended by the manufacturer.
11. To disconnect from the wall outlet, push the switch to the off position, then remove the plug from outlet pulling from the plug, not the cord. Never operate the PLATINUM™ 16 quilting machine if the cord is damaged or not working correctly. If a mechanical or electrical problem is encountered, return the PLATINUM™ 16 quilting machine to the nearest authorized service center or the manufacturer for examination, repair, electrical or mechanical adjustment.

## Quick Facts

The PLATINUM™ 16 quilting machine utilizes high-tech electronics and an innovative touch-pad user interface to offer greater functionality and ease of operation to home quilters than ever before conceived in the quilting industry. The PLATINUM™ 16 quilting machine is a high quality machine that incorporates very robust design features and is very easy to service.

Throat Dimensions:	8.25” X 16” (245 mm X 610 mm)
Quilting Speed:	Maximum: 1500 SPM
Needle System:	134 (135 X 7)
Needle Sizes:	12/80 - 20/125
Hook System:	Rotary, Vertical, M-class bobbin
Bobbin Type:	Aluminum, Class M
Bobbin Case:	Type MF
Motor Type:	Brushless DC
Needle Positioning:	Up and down, tie-off stitch
Electrical Power:	100-250 VAC, 47-63Hz, 300W peak
LED Power Consumption:	2.25W
Hopping Foot Stroke/Lift:	5 mm
Needle Bar Stroke:	35.3 mm
Take-Up Stroke:	73 mm
Lubrication, main components:	Kluber Lube, permanent
Lubrication of hook:	Velocite 10, Texaco 22

### **Disclaimer**

*SVP Worldwide and its Representatives are in no way legally responsible or liable for damage to the PLATINUM™ 16 quilting machine when used improperly or not in accordance with the guidelines stated in this manual or when used on machine-quilting tables not recommended by SVP Worldwide.*

# PLATINUM™ 16 Quilting Machine Components

## Front Side View

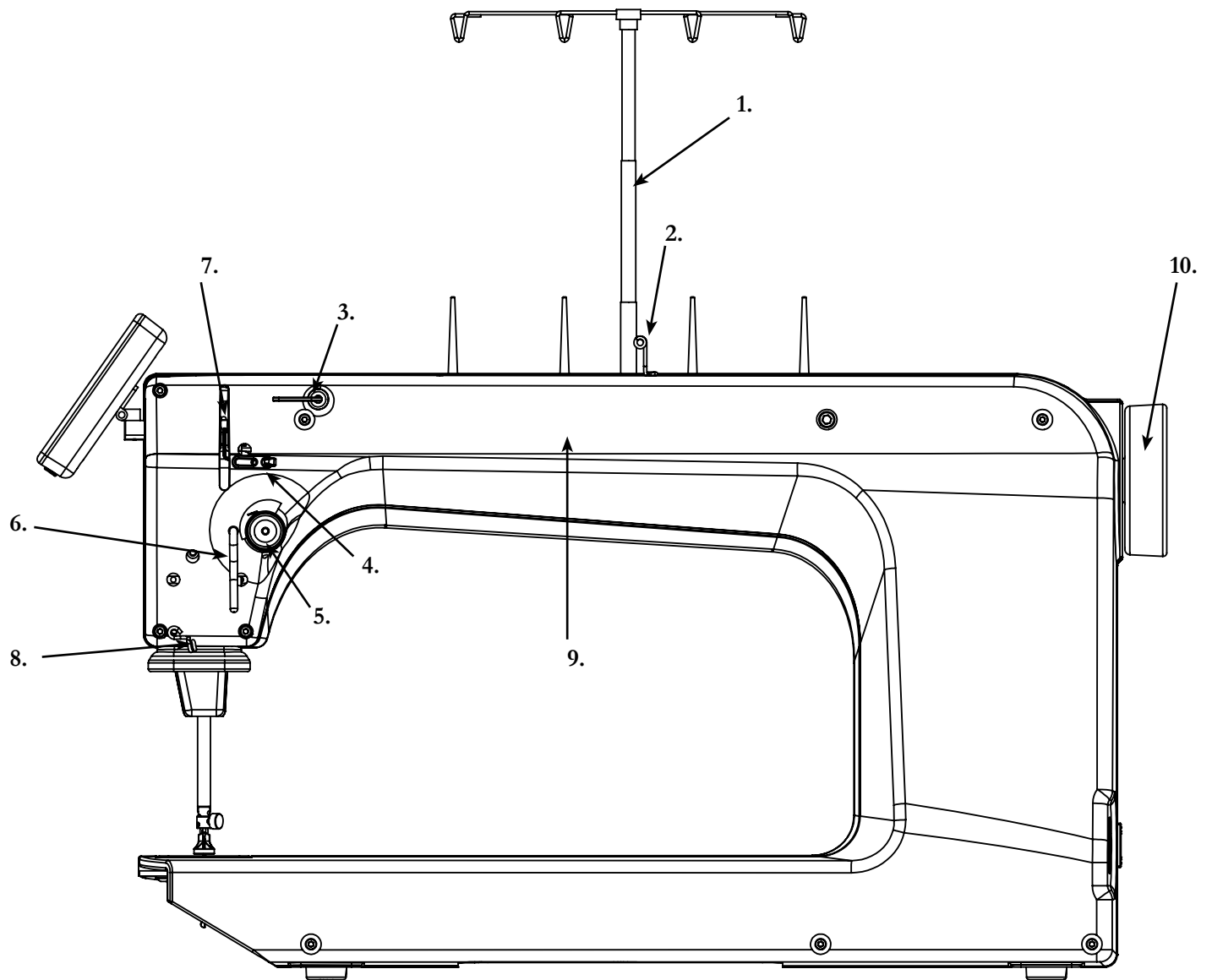

Figure 1

1. Thread Stand
2. Thread Guide A
3. Three-Hole Thread Guide B
4. Thread Guide C
5. Top Thread Tension Assembly
6. Stirrup Thread Guide E
7. Take-Up Lever
8. Thread Guide F
9. Front Casing/Frame
10. Hand Wheel

# Back Side View

- 11. Needle Bar
- 12. Needle Bar Thread Guide
- 13. Needle
- 14. Hopping Foot
- 15. Needle Plate
- 16. Needle Clamp Screw
- 17. Front Display

- 18. Back Casing/Frame
- 19. Color Touch-Screen Display Connector
- 20. Threaded Horizontal Spool Pin Mounting Hole

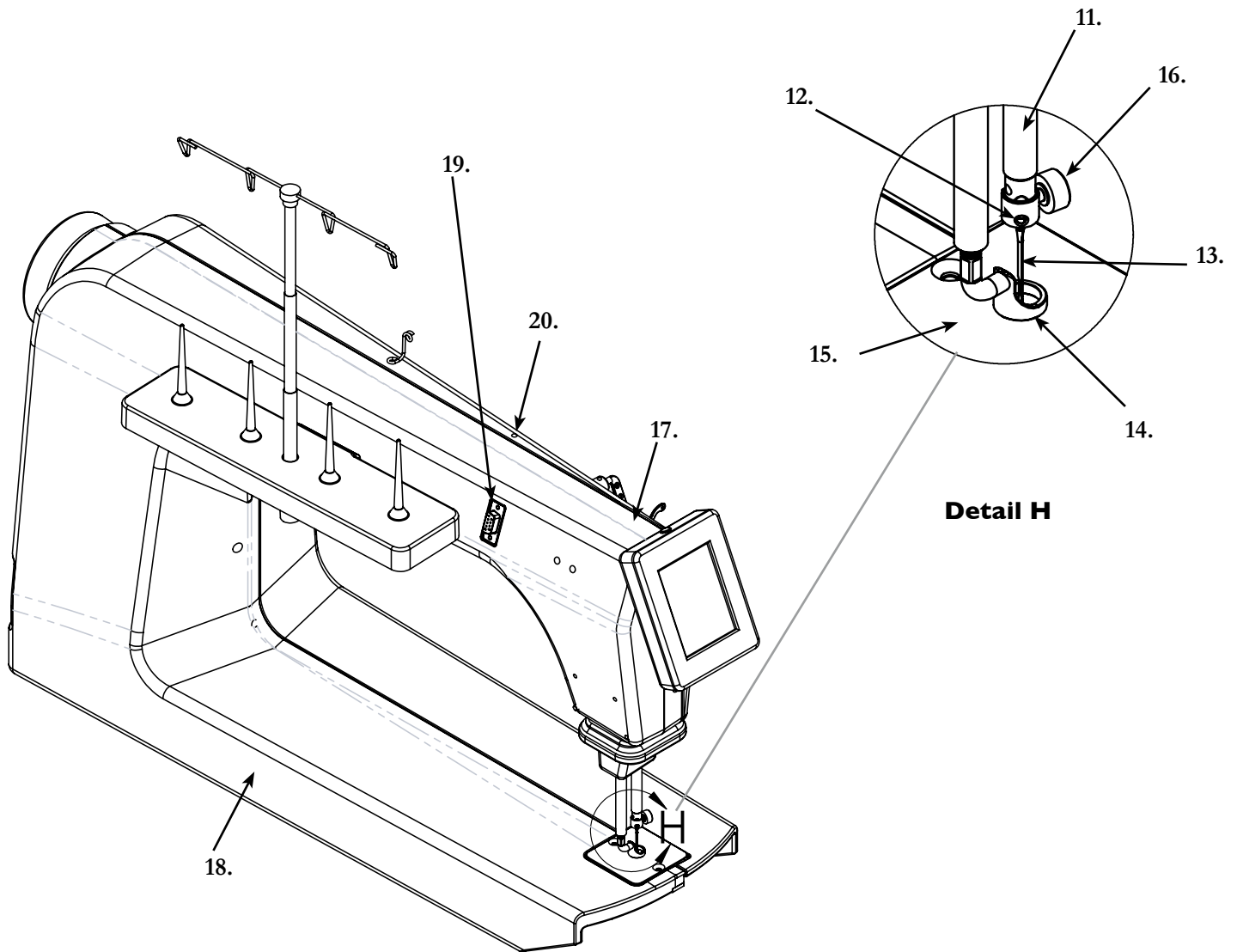

Figure 2

## Rear and Front Views

- 21. On/Off Switch
- 22. Power Cord Connector
- 23. Foot Pedal Connector
- 24. Spool Pins
- 25. Thread Stand
- 26. Bobbin Assembly
- 27. LED Light Ring

## Included Accessories

- 4 M-Class Bobbins
- INSPIRA® Needles Size 16
- Bobbin Case Screwdriver
- Lint Brush
- Pen Oiler
- Power Cord

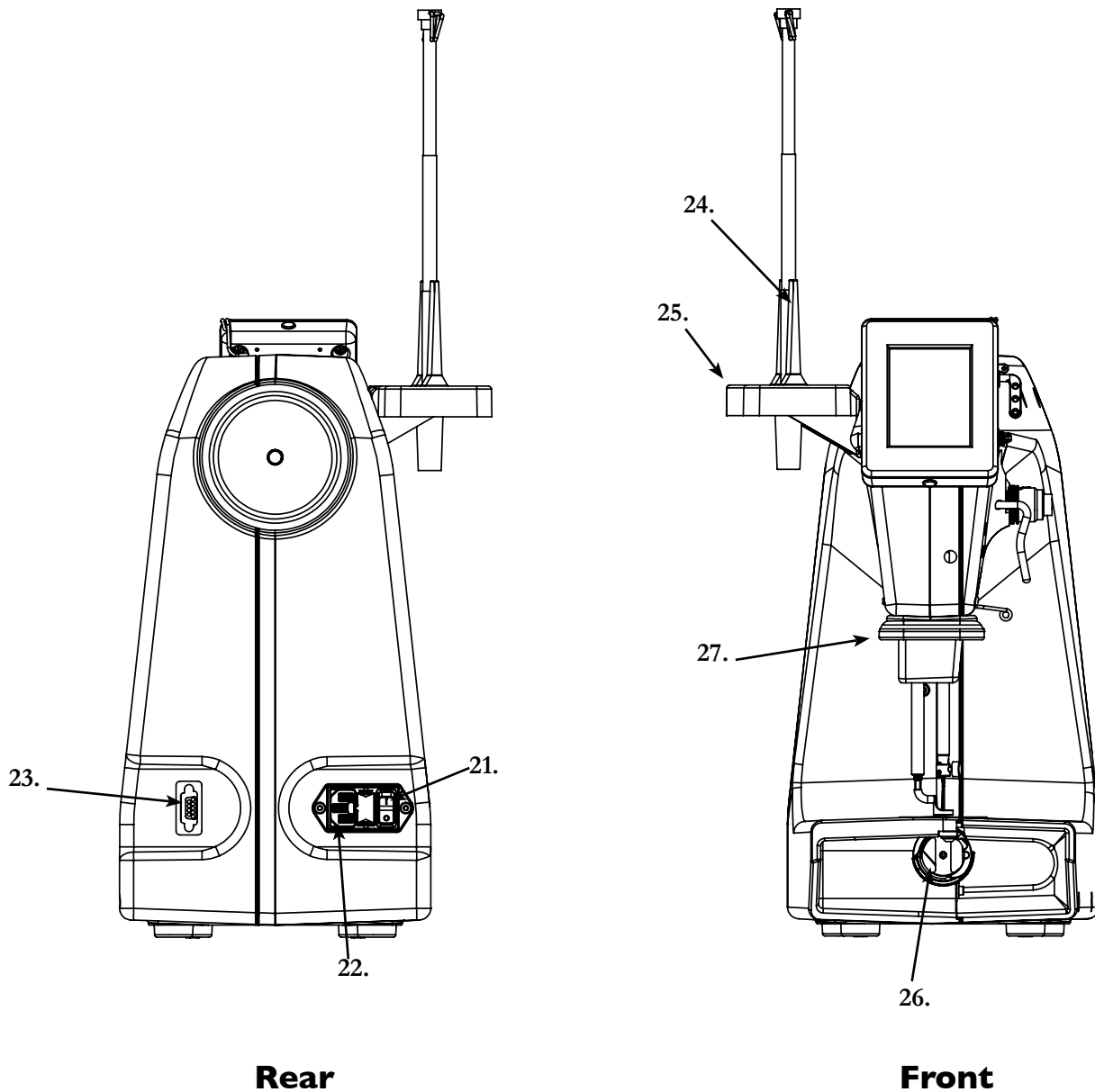

Figure 3

## Setting Up the Table (and Taking it Down for Storage)

The PLATINUM™ 16 quilting machine table has been designed to accommodate the PLATINUM™ 16 quilting machine. It has folding legs that are height-adjustable and is heavy enough to provide stabilization for quilting at high speeds.

1. Open the box and gently remove the table, taking care not to drop the table on the floor. The table weighs nearly 50 pounds, so it is recommended that you ask someone to help.
2. Remove the bracer.
3. Unfold the legs, pulling on the horizontal braces until the legs snap into place. Set the table upright.
4. Make the table taller by pinching the two height-adjustment tabs on each set of legs and lifting on table, while holding legs down with foot. Make the table shorter by pinching the same tabs and pushing down on the table.
5. To store the table, remove machine and return legs to their lowest position.
6. The legs are attached to the table top with brackets of two different sizes. One is longer than the other. Identify the long and the short leg brackets.
7. Fold in the short bracket leg first. Push on the horizontal braces to loosen the legs and push them back toward the table top.
8. Repeat with the long bracket leg.

## Placing the Machine in the Table

1. We recommend having someone help lift and place the machine.
2. Lift the machine by putting one arm through the throat space.
3. Guide the machine from the back of the table into the slot. Machine is positioned correctly when the back of the machine is flush with the back of the table.

## Installing the Power Cord



Figure 4

Check that the On/Off switch (page 12, Figure 3, #21) is turned off (the 0 setting). Plug the power cord into the power outlet on the back of the machine (Figure 4). Do not plug the power cord into a power source at this time.

## Installing the Foot Pedal

1. Plug in the foot pedal cord end into the foot pedal connector (see page 12, Figure 3, #23).
2. Place the foot pedal under the table where operator can reach it from the front of the machine.

## Installing the Thread Stand



Figure 5

1. Locate the two threaded holes on the left side of the machine, near the top and towards the middle.
2. Remove the 2 screws. Line up the holes of the thread stand with the holes on the machine and reinsert the screws.
3. Turn the thread stand until the eyelets are positioned over the spool pins.

**Note:** The eyelets of the thread stand *MUST* be centered over the spool pins. This ensures that the cone of thread will not pull, turn or tilt, which will cause thread tension problems (see **Figure 5**).

## Installing the Color Touch-Screen



Figure 6

The color touch-screen comes pre-installed on its mounting bracket and should have one end of the D cable attached to the back of the touch-screen (see Figure 6).

**NOTE:** Confirm that the power is turned off before installing the Color Touch-Screen.

1. Align the holes in the color touch-screen bracket hinges with the 4 holes on the front of the machine, with the touch screen facing the needle end of the machine.
2. Use a Phillips screwdriver to tighten the 4 screws through the holes of the hinges and into the machine (Figure 6). Tighten in place.
3. Plug the remaining cable end into the display connector located on the side of the machine (page 11, Figure 2, #19).
4. Remove the protective plastic from the touch-screen before using.

## Inserting (or changing) the Needle

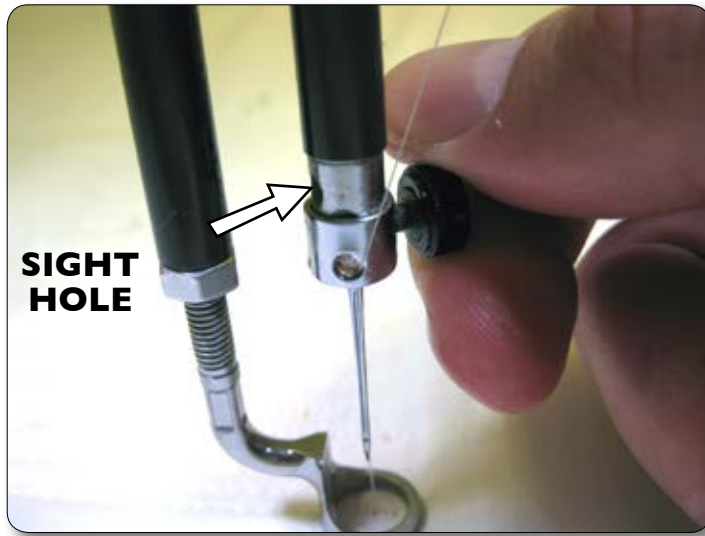

Figure 7

The needle that is in the machine when it arrives at your home has been used for 20 minutes of testing. It is possible that it could be damaged in shipping or as you remove the machine from the box. For these reasons, we recommend that you replace the needle before beginning to quilt with your new machine.

1. Move the needle bar to the highest position by turning the hand wheel.
2. Confirm that the power is off and that the machine is unplugged.
3. Loosen the needle-bar clamp thumb screw (see Figure 7) enough to assure that the needle can be inserted all the way up to the top of the sight hole.
4. With the scarf (small ground out section/dip on the back side of the needle just above the needle eye) facing the hand wheel end of the machine, and the long groove down the front of the needle facing the bobbin case side (see Figure 7), push the needle all the way up into the needle bar - until it can go no further. Look into the sight hole to verify that the butt of the needle reaches the top of the sight hole.
5. Carefully tighten the thumb screw. Over-tightening the thumb screw will result in damaged threads or stripping of the screw hole. Stripped holes are not covered under warranty. To avoid over-tightening the screw, finger-tighten only.

*Note: Changing the needle is recommended for each new quilt loaded on the machine or any time the needle becomes bent, dull or burred.*

*Needles are inexpensive and are important to the success of your project. Plan to change needles every 5-7 hours of quilting or more often if working with a lot of fusibles or heavy materials.*

## Needle/Thread Selection Guide

Needle Size	Threads
14 (90)	Silk (100 wt) 60 wt., monofilament, glitter, some metallics
16 (100)	60 wt., 50 wt., 40 wt., monofilament, glitter, metallics
18 (110)	50 wt., 40 wt., 30 wt., metallic
20 (120)	30 wt., 20 wt., 12 wt.

## Adjusting the Hopping Foot

The foot is adjusted at the factory and should not be moved without consulting your dealer.

# Threading the Machine

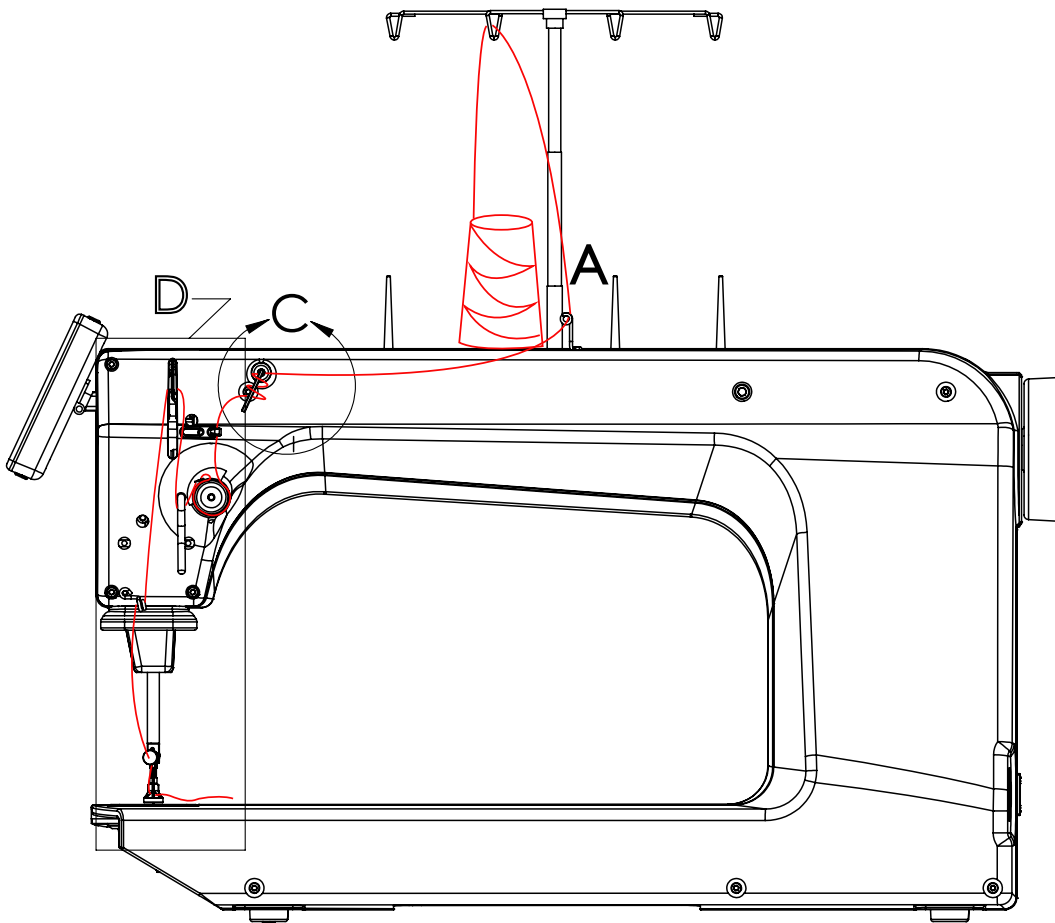
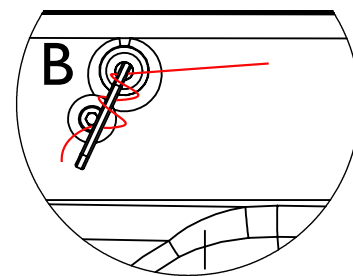

Figure 8

1. Place a cone or spool of thread on the spool pin. If using a spool, make sure that the slits on the spool are against the base of the spool pin holder. Pass the thread through the thread-stand eyelet from back to front, continuing to thread guide A. (Figure 8)

2. Continue to the three-hole thread guide B. Beginning at the top, wrap all three holes from back to front, hand wheel side to needle side (see Figure 9).

*Note:* The purpose of the three-hole thread guide B is to prevent loops of thread coming off the thread cone from going into the top tension as a knot can cause thread breakage and bad tension. For most threads on a cone, it is important to thread all three holes for consistent results and to make adjustments at the top tension assembly. An exception to this rule is when working with very delicate threads, such as holographic or threads that are prone to breakage. You may try skipping one or two holes on thread guide B when using these threads.



DETAIL C

Figure 9



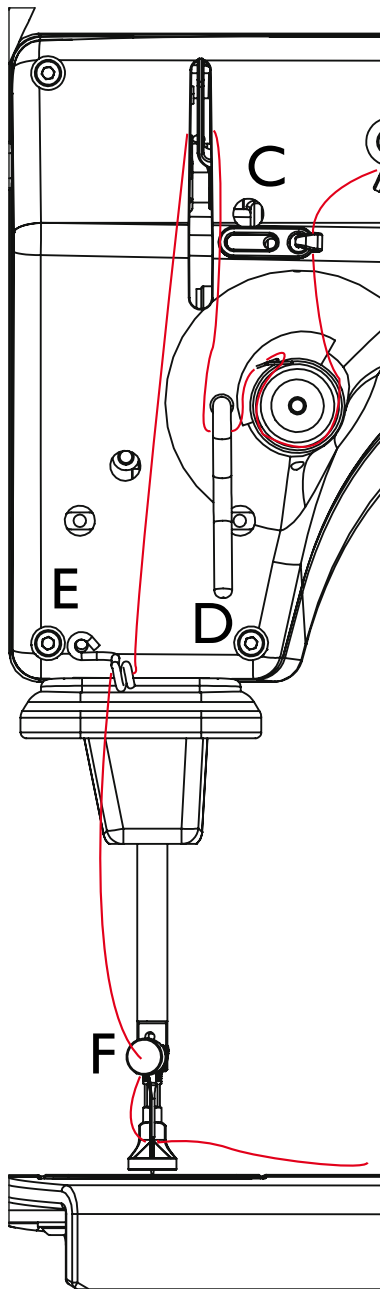

DETAIL D

Figure 10

3. Thread continues through thread guide C, and then down to the tension assembly (see Figure 10).

*NOTE: It is important that the thread is “flossed” up between the two tension discs. If the thread is not firmly in place between the two tension discs, the thread rests on the outside of the tension discs (without tension) and looping on fabric or thread nests may occur.*

4. Once the thread is in place, be sure that the thread catches on the take-up spring and then pull it down under the stirrup (thread guide D).

5. Bring the thread back up through the take-up lever from back to front, and then down through thread guide E. Pull the thread at the take-up lever to ensure that it is properly flossed between the tension disks. If it is properly flossed in the tension disks you should feel some resistance as you pull the thread. If it is not, then the thread will pull freely.

6. Pull the thread down to the needle thread guide and thread through the hole (thread guide F).

7. Make sure the thread is following the groove down the front of the needle and threads from front to back. Be careful that the thread does not twist around the needle.

**IMPORTANT NOTE:** The PLATINUM™ 16 quilting machine does not have a presser foot lever or top tension release like a home sewing machine. On a home sewing machine the top tension is released when the presser foot is raised, allowing the thread to come freely out of the machine. When a home machine is threaded, the presser foot is raised and the tension discs are released and open for the thread to easily fall between the tension discs. This is not the case with the PLATINUM™ 16 quilting machine where the top tension is always tight and the tension discs are never open. Therefore, the thread must be pulled up or “flossed” between the tension discs or it will stay outside the discs and float without tension, causing serious stitch problems and/or thread nests. It is also possible to bend the needle while it is threaded if care is not taken while moving the machine around the quilt because the top tension is never released.

# Bobbin and Thread Tension Adjustments

## Inserting the Bobbin

**Note:** Turn off the power switch while inserting the bobbin case or anytime your hands are near the needle area.

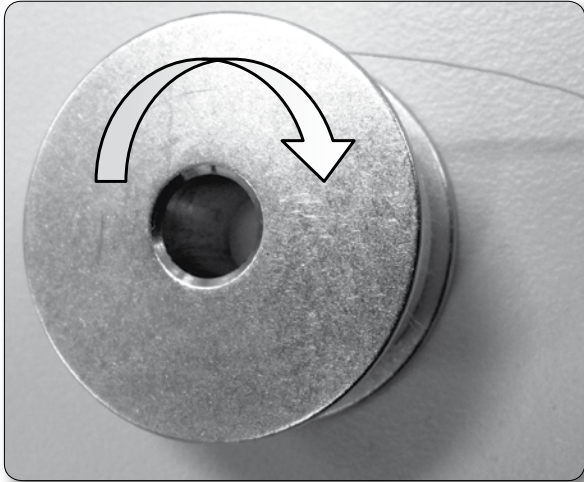

Figure 11

1. Place the bobbin in the bobbin case so that the thread pulls off clockwise when viewing the open side (Figure 11).

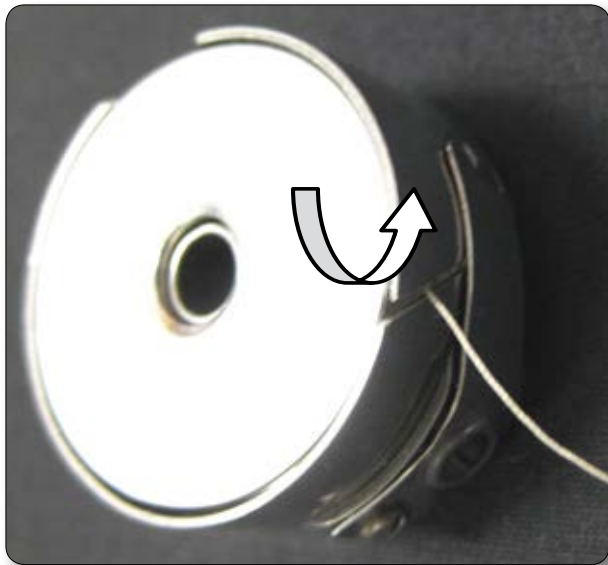

Figure 12

2. Slide the thread through the slot (Figure 12) and under the tension spring leaving 5-6 inches of thread hanging loose (Figures 12 and 13).



Figure 13



Figure 14

3. To insert the bobbin case into the machine, grasp the bobbin case with thumb and first finger. Do not lift the lever on bobbin case. Fit the bobbin case onto the hook spindle in the machine. Rotate the case until the open throat keys into the alignment notch in the middle of the hook. Push the case in until it stops in place. Push the case inward further until it clicks (see Figure 14). Allow the thread end to hang freely.

**NOTE:** Pulling out the latch lever pushes the bobbin forward in the bobbin case, aiding in removal of the bobbin. The lever should be used only for removing the bobbin case from the machine.

## Drawing the Bobbin Thread to the Top of the Quilt

1. After threading the machine, plug it in and turn on the power. Place quilt sandwich under hopping foot.
2. While firmly holding the tail of the needle thread with the left hand, choose one of the following methods to cycle the needle through one full rotation to bring the bobbin thread to the top of the quilt.
  - A. Foot Pedal Method. LIGHTLY tap the foot pedal to make the needle go down. Then LIGHTLY tap again to bring the needle up.
  - B. Needle Up/Down Button Half-Stitch. Find the Needle Up/Down Button in the lower left of the color touch screen main display. Press once to cycle the needle down. Press again to cycle the needle back up.
  - C. Needle Up/Down Button, Full-Stitch. Find the Needle Up/Down Button in the lower left of the color touch screen main display. Press and hold briefly to cycle the needle through one complete stitch cycle (down and back up).
3. Pull the fabric 3-4 inches away while holding the needle thread.
4. Bobbin thread will pull up and through to the top, allowing you to grasp the loop and pull it to the desired length.

## Checking and Adjusting Bobbin Case Tension

The bobbin case tension is the foundation tension for the entire machine. To test that bobbin tension is correct, hold the bobbin case in the palm of your hand with the open end facing up. Wrap the thread around your index finger and lift the bobbin case from your hand. While gently moving the finger front to back (not up and down, which is not consistent), the bobbin case should slide slowly down the thread, like a spider on its web.

The small screw in the center of the tension spring is where the adjustment is made (see Figure 15). Turn clockwise to tighten and counter-clockwise to loosen the bobbin case tension. Make very small adjustments. Check the bobbin tension every time a new bobbin is inserted.



Figure 15

## Tighten Bobbin Case Tension

The bobbin case tension is TOO LOOSE if it will not lift up onto its side. Turn screw clockwise to tighten. The bobbin case screw requires very small adjustments. Think of the “tick of a clock”. Adjust, then check. Adjust and check again.

## Loosen Bobbin Case Tension

The bobbin case tension is TOO TIGHT if it lifts out of your hand. Turn screw counter-clockwise to loosen. The bobbin case screw requires very small adjustments. Think of the “tick of a clock”. Adjust, then check. Adjust and check again.

## Top Thread Tension Adjustment

**IMPORTANT NOTE:** Top thread tension should be adjusted only after the bobbin case foundation tension adjustment is made.

Puckering, gathers and thread breakage occur when the top tension is too tight. Loops and thread nests occur on the back when the top thread tension is too loose. (See Figure 16 on next page.) Tension may need to be adjusted, depending on the fabric, thread or batting used in each project.

Unlike the bobbin case adjustment, which requires minute adjustments (like the tick of a clock), the top tension knob may require turns anywhere from 1/4 of a turn to 2-4 turns to achieve balanced tension.

## Tighten Top Thread Tension

To adjust the top tension tighter, turn the top thread tension knob (page 10, Figure 1, #5) clockwise.

## Loosen Top Thread Tension

To loosen the tension, turn the top thread tension knob (page 10, Figure 1, #5) counter-clockwise.

**NOTE:** Before adjusting the top tension, remember to floss or pull the top thread up into the tension discs or it will float outside the discs providing little or no top tension. This could cause significant tension or nesting problems on the bottom side of the quilt. If the top tension is too loose (causing loops of thread on the underside of the quilt) and no amount of tightening the top thread tension knob seems to affect it, there's a good chance that the thread is riding on the outside of the tension discs and is not "flossed" between them.

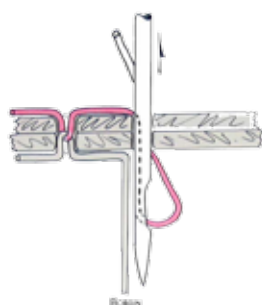

A stitch is balanced when the top thread and the bobbin thread meet in the middle of the quilt sandwich.

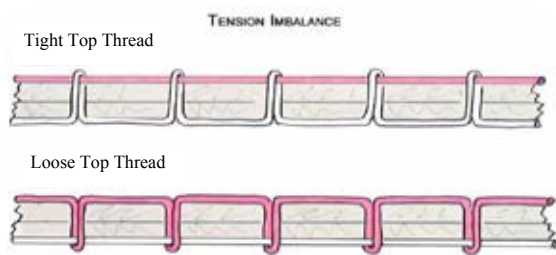

Figure 16

## Maintenance

**NOTE:** Turn off the machine and remove the power cord when performing maintenance on the machine.

### Cleaning and Lubricating the Machine

Only use light sewing machine oil in the PLATINUM™ 16 quilting machine. Internal oiling is not necessary on the PLATINUM™ 16 quilting machine except when the machine is taken to a service technician for routine maintenance and cleaning. The hook assembly, however, needs regular lubricating. Failure to keep the hook assembly lubricated can cause severe damage to the machine.



Figure 17

To lubricate, turn off the machine. Remove the bobbin and case before oiling. Clean around the hook assembly with a soft brush to remove lint. Put a very small drop of oil on the hook in the region where the bobbin basket assembly and the rotating hook meet (see Figure 17). The bobbin basket is the portion of the hook that the bobbin case snaps into. The bobbin basket remains stationary while the hook rotates around the basket. The oil lubricates the region where these two components interlock. A drop of oil in the region indicated will work its way back into the interlocking area of the hook and bobbin basket.

The frequency of lubrication depends upon the usage of the machine. Lubricating is recommended before running the machine if it has not been used regularly, or every other bobbin change if used frequently. After oiling, always stitch through a scrap piece of fabric, as oil may cling to thread. Over-oiling can cause excess dripping from the bobbin assembly. Lack of lubricant may be noticed by a change in the sound of the machine and will affect stitch quality.

### Cleaning the Touch-Screen Display

Use a soft rag dampened with isopropyl alcohol to gently wipe the display and remove any marks. Never use any other chemicals to clean your display as they may adversely affect the touch-screen response and clarity.

# Using the Touch Screen Displays

## Display Menus

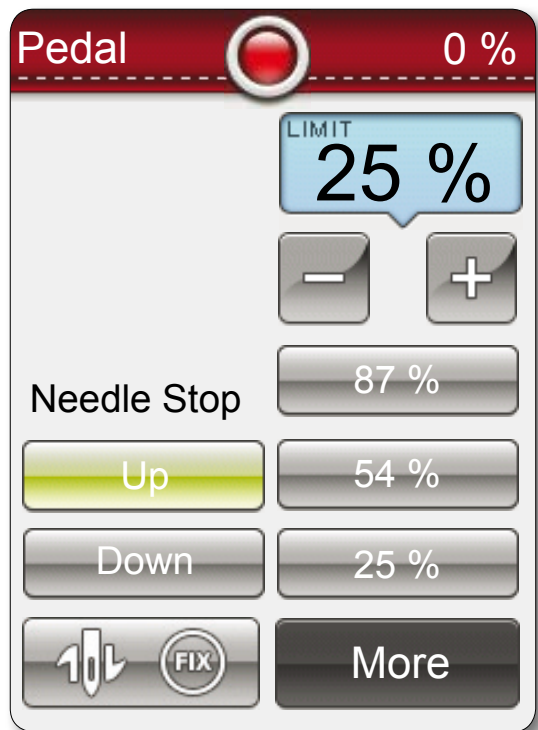

Figure 18



Figure 19

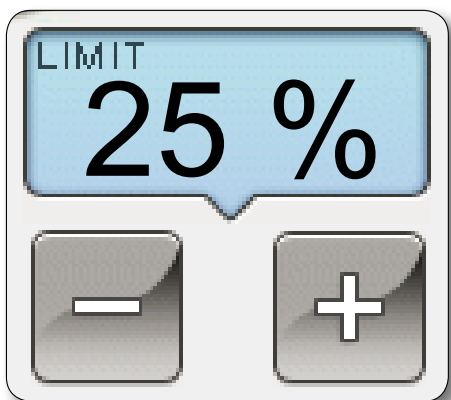

Figure 20

The PLATINUM™ 16 quilting machine has a color touch-screen display on the front of the machine. Settings are changed using this display.

### Main Screen Button Functions (Figure 18)

#### Pedal Status

The status of the foot pedal connection is displayed in the top left corner of the Main screen (Figure 18). If the foot pedal is not properly connected the message “Check Pedal” will appear. Once the pedal is connected properly the word “Pedal” appears in that space.

#### On/Off Indicator

The box in the center of Figure 19 indicates whether or not the motor is running. It will be red when the machine is stopped and green when the foot pedal is pressed.

#### Current Speed

The box in the top right of Figure 19 is the current percentage of full speed the machine is running. The value displayed will vary as you press and release the foot pedal. The maximum percentage value that is displayed is controlled by the Limit that is set for the machine.

#### Limit Controls

The Limit box encompasses two main features, the “My Speed” controls and Preset buttons. The My Speed controls consist of “+” and “-” buttons and the My Speed display box (Figure 20). Pressing the “+” button will increase the maximum motor speed the pedal controls. Pressing the “-” button will decrease the maximum speed.

The My Speed range is between 5 % and 100 % or between 75 and 1500 stitches per minute (SPM). The current percentage My Speed value is displayed in the box under the “Limit” text. This My Speed setting will be preserved when the machine is shut off, allowing you to begin quilting again at the same speed when you turn the machine back on.

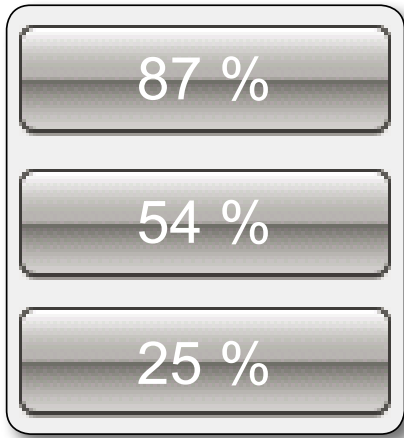

Figure 21

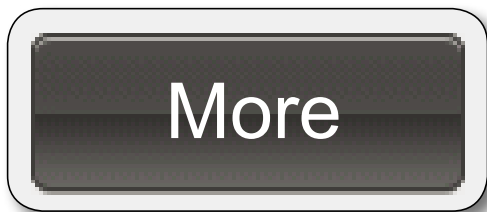

Figure 22

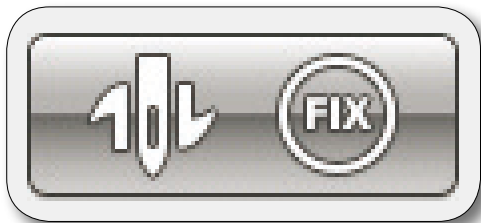

Figure 23

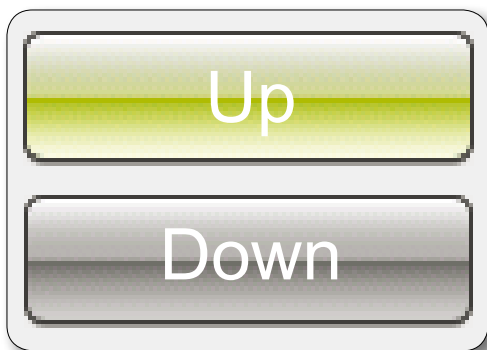

Figure 24

The second feature of the Limit box are three buttons called Presets that can be customized to your favorite speed settings (Figure 21). Pressing a Preset button will change the “My Speed” setting to the speed shown on that button. This feature makes it quick and easy to switch between different speeds preferred for different types of quilting. For example you may wish to use a slower speed for detail work and a faster speed for stippling. Changing these Preset values is discussed in the “Presets Screen” section.

### More

Pressing the “More” button (Figure 22) will change to the “More” menu screen, which allows access to lighting options, sound options, diagnostics menus, system information, Preset button customization and a calculator.

### Up/Down/Tie-Off

The button with the needle image in the center of the screen can assist you in creating tie-off stitches, basting or needle-positioning functions without the use of the foot pedal (Figure 23). Pressing and releasing the button quickly will send the needle to the next needle stop position. If the needle is up, pressing the button will cause the needle to move to the down position. If the needle is down, it will return to the up position.

Pressing and holding the button for a longer time allows you to do a full stitch. As long as you continue to hold the button down the machine will continue to stitch at a slow rate, and when the button is released the needle will stop in the closest stop position (up or down) available. This action is useful for tying off beginning and ending stitches.

### Needle Stop

When in “Needle Up” mode, the needle ends in the “Up” position upon release of the foot pedal. This button does not move the needle, but simply determines the final needle position after the machine has been stopped. (Figure 24)

When in “Needle Down” mode, the needle ends in the “Down” position upon release of the foot pedal. Again, this button does not move the needle, but sets the final resting position of the needle after the foot pedal is released.

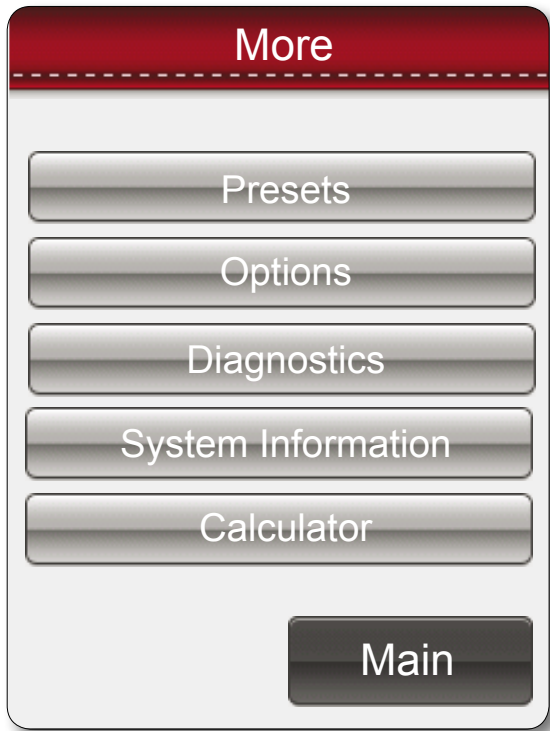

Figure 25

## More Menu (Figure 25)

The More screen allows access to other functions available on the PLATINUM™ 16 quilting machine. (Figure 25)

### **Presets**

Press the “Presets” button to adjust the three available speed presets.

### **Options**

Pressing the “Options” button will open a screen that allows adjustment of the sound volume and the LED Light Ring brightness.

### **Diagnostics**

The “Diagnostics” button activates the screen where machine diagnostic functions can be performed. Diagnostic functions are generally only used when working with our Technical Support to resolve issues.

### **System Information**

The “Sys. Info.” Button provides access to machine information. This includes the machine Serial Number, the hardware and firmware version numbers and the Stitch Counters.

### **Calculator**

An on-screen calculator may be accessed from the “More” screen.

### **Main**

Press the “Main” button to return to the Main menu screen.

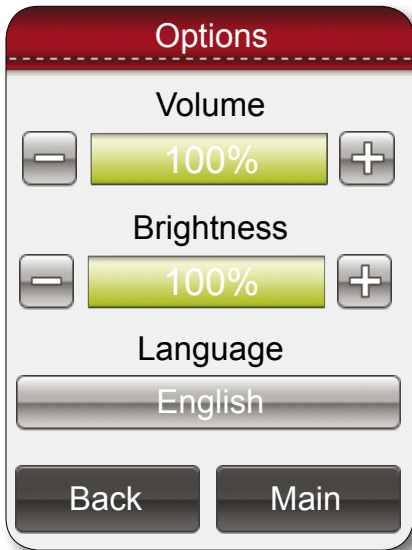

Figure 26

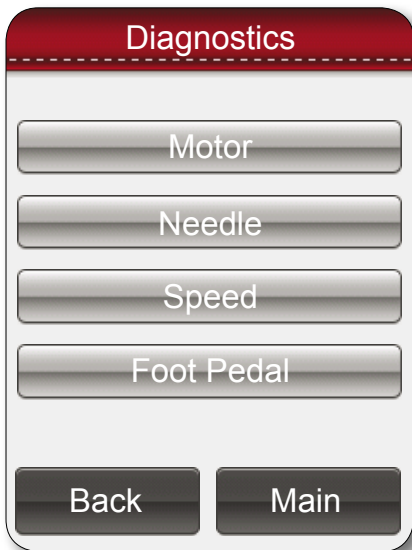

Figure 27

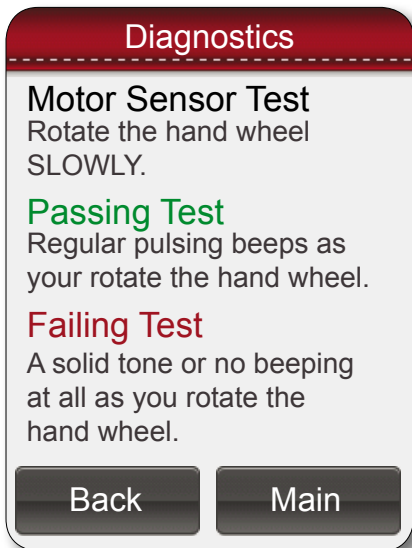

Figure 28

## Options Screen (Figure 26)

### Volume

The “Volume” portion of this screen has two buttons and a sliding control. Pressing on the “minus -” button lowers the sound of the buttons when they are pressed. Pressing the “plus +” button turns the volume to its loudest level. Pressing the sliding control in any position sets the volume to the level indicated in that control. Pressing and moving back and forth across the sliding control will change the volume up as it is moved left to right and down as it is moved from right to left.

### Brightness

The “Brightness” portion of this screen has two buttons and a sliding control as well. The LED Light Ring can be turned on completely with the “plus +” button or off completely with the “minus -” button. Pressing the sliding control in any position will set the brightness to the value indicated in the slider control. Pressing and moving back and forth across the sliding control will change the brightness up as it is moved left to right and down as it is moved right to left.

Press the “Main” button to return to Main menu screen or the “Back” button to return to the “More” menu screen.

## Diagnostics Screen (Figure 27)

Four different diagnostics tests can be performed on the machine. These functions test the motor control operation, the foot pedal and the internal position sensors.

Press the “Main” button to return to the “Main” menu screen or the “Back” button to return to the “More” menu screen.

## Diagnostics Tests (Figure 28)

### Motor Sensor Test

The “Motor” Sensor test can help you determine whether they may be a problem with the PLATINUM™ 16 quilting machine motor. Slowly rotating the hand wheel should result in an audible “beep.” If you get a constant solid “beep” or no “beep” at all, this indicates a failed test and the machine should be inspected by a qualified HUSQVARNA VIKING® repair technician.

Press the “Main” button to return to the “Main” menu screen or the “Back” button to return to the “More” menu screen.



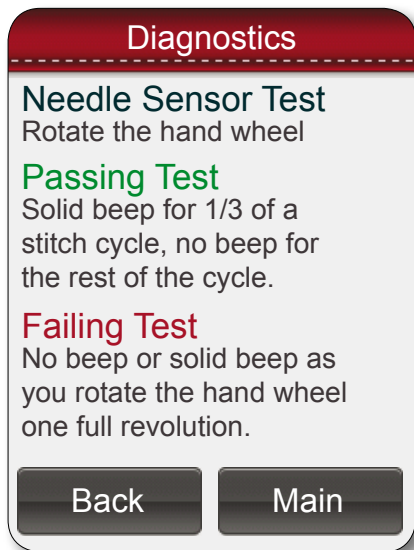

Figure 29

### Needle Sensor Test

The Needle Sensor test will indicate whether the needle position sensor is functioning properly. Rotating the hand wheel should result in a “beep” for half of a stitch cycle followed by no “beep” for the other half. (Figure 29)

If you hear a constant beep or no beep at all for a full 360° rotation of the hand wheel, this indicates a failed test and the machine should be inspected by a qualified HUSQVARNA VIKING® repair technician.

Press the “Main” button to return to the “Main” menu screen or the “Back” button to return to the “More” menu screen.

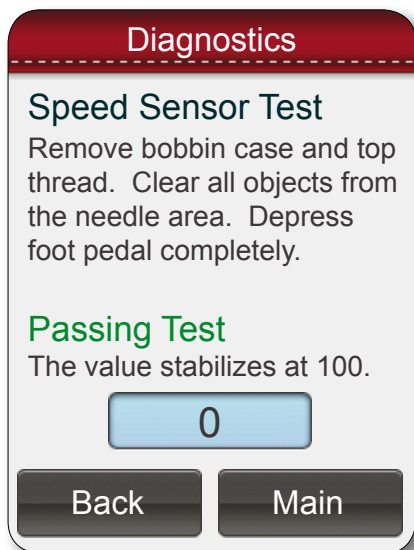

Figure 30

### Motor Speed Sensor Test

The “Speed” Sensor test can help you determine whether or not there is a problem with the PLATINUM™ 16 quilting machine speed sensor. Before performing this test, remove the bobbin case and the top thread. Press the foot pedal so that the machine will begin slowly rotating. The box will show a number that should stabilize at 100 if the sensor is functioning properly. Release the foot pedal to stop the machine. (Figure 30)

Press the “Main” button to return to the “Main” menu screen or the “Back” button to return to the “More” menu screen.

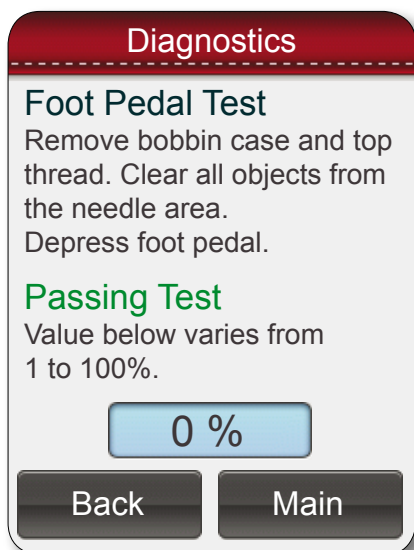

Figure 31

### Pedal Test

The “Pedal” test can help you determine if there is a problem with the PLATINUM™ 16 quilting machine foot pedal. As you slowly depress the foot pedal a percent of depression will appear in the box. The foot pedal should be controllable from 0 to 100%. (Figure 31)

Press the “Main” button to return to the “Main” menu screen or the “Back” button to return to the “More” menu screen.

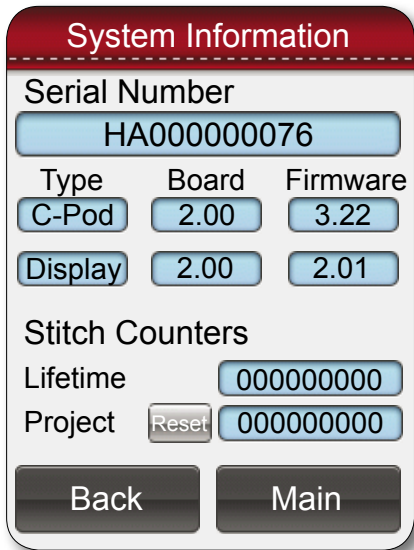

Figure 32

### System Information Screen

The serial number of the machine is displayed at the top of the System Information screen. This number matches the one found on the label at the back of the machine.

Information contained in the white boxes below the serial number identifies the electronics board revision numbers as well as the firmware revision numbers of the PLATINUM™ 16 quilting machine and its handlebars.

The Lifetime and Trip (or project) stitch counters count the number of stitches the machine is performed. The Lifetime count is the total number of stitches made since the machine was built. The Trip Counter can be reset to keep track of the number of stitches made during a given project. To reset this counter, press the “Reset” button found aligned with the Trip counter.

The Lifetime counter cannot be reset and should be used as an indicator to determine when general machine maintenance should be performed by an authorized HUSQVARNA VIKING® Representative. (Figure 32)

Press the “Main” button to return to the “Main” menu screen or the “Back” button to return to the “More” menu screen.

### Calculator Screen

A basic six-function calculator is provided for your convenience. (Figure 33) The functions provided are addition, subtraction, multiplication, division, square root and percent. The delete key on the top right may be used to delete a digit mistakenly entered.

Press the “Main” button to return to the “Main” menu screen or the “Back” button to return to the “More” menu screen.



Figure 33

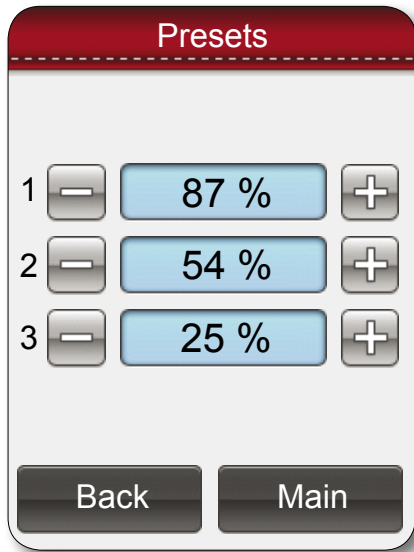

Figure 34

### Presets Screen

Pressing the Presets button will take you to a screen that allows you to customize the preset button speed settings (Figure 34). There is a "+" and "-" button for each of the three presets and a blue box that displays the current setting.

The top preset value indicated by the number "1" box on the left adjusts the top button on the main screen. Pressing the "+" button will increase the preset speed and pressing the "-" button will decrease the speed. These presets are saved so that they are preserved even if the machine is turned off.

Press the "Main" button to return to the "Main" menu screen or the "Back" button to return to the "More" menu screen.

# Getting Started Quilting

## Thread Requirements

Threads have a tendency to dry rot over a period of time. Be sure to choose high quality threads for your valuable heirloom quilts. Most machine quilting threads on the market today are acceptable.

## Needle Requirements

For general quilting, a size 16/100 needle will accommodate most threads and fabrics. Heavier threads, such as top stitch and some decorative threads, require a larger needle such as 18/110 or 20/120. Heavier fabrics such as denim, canvas or densely woven fabric may require a larger needle.

## To Prepare for Quilting

With any quilting machine, it is important to understand the basics of free motion quilting. The PLATINUM™ 16 quilting machine Quilting Machine does not have feed dogs like domestic machines; therefore, the fabric does not automatically feed under the hopping foot. The operator controls the machine sewing speed with the My Speed setting and the foot pedal, and moves the fabric to get an even, consistent stitch.

In order to become comfortable using the PLATINUM™ 16 quilting machine, quilters can begin with a few simple techniques using a sample quilt sandwich (two pieces of fabric with a layer of batting between them).

Set the machine at a medium My Speed setting (perhaps 25%) and begin moving the fabric until you become accustomed to the resistance. By moving the fabric faster, the stitches begin to elongate. The My Speed setting can either be increased or the fabric can be moved slower to get the stitches back to the desired length. By moving the fabric slower, the stitches get shorter and can build up on top of each other, breaking the thread or making it extremely difficult to unpick.

The My Speed setting can be decreased or the foot pedal released slightly, while maintaining a constant motion with the fabric, to bring the stitches back to the desired length.

When quilting, relax your hands and maintain a light touch on the fabric. Gripping the fabric too tightly may cause body tension resulting in poor quilting quality and discomfort.

Different colors of fabric may require different brightness settings for the LED light ring to prevent eye strain.

## Correcting Common Issues

Skipped Stitches	Corrective Measure
<ul style="list-style-type: none"> <li>• The needle is damaged, dull, bent, or installed improperly</li>   <li>• Incorrect needle size</li> <li>• Very tightly-woven fabric (such as batiks)</li>   <li>• Needle has not been positioned properly</li>   <li>• Thread tension too tight</li> <li>• Improper threading</li> </ul>	<ul style="list-style-type: none"> <li>• Replace the needle often, normally once or twice per day for continuous quilting or at least once per quilt. Use PLATINUM™ 16 quilting machine recommended needles.</li> <li>• Always change the needle if the needle has struck any hard object such as a straight pin, etc. The tip of the needle can become damaged or burred, resulting in fabric damage as well as skipped stitches, thread breakage or shredding.</li> <li>• Always change the needle if it has been hit, bumped or pulled off center while maneuvering the machine about the quilt. A slightly bent needle can be a major cause of skipped stitches.</li>   <li>• Check for the proper combination of needle size and thread weight being applied to the quilting operation. Some fabrics used in quilting may constrict or impede the thread passing through the front groove of the needle. This diminishes the loop lift required for stitch formation. Typically, a larger needle will solve the problem; however, it has been found that certain smaller sizes of needles as well as the use of ball-pointed needles solve some specific problems.</li> <li>• Position the needle properly to the needle bar. Inspect the position of the needle to make sure the needle is at the 6 o'clock position (see figure 16, page 20)—If you stand directly in front of the needle (facing the bobbin case side of the machine), you will see the entire needle eye directly facing you. This is 6 o'clock position.</li> <li>• Make sure (1) the needle is installed all the way into the needle bar to the needle stop hole in the needle bar, (2) the long groove in the needle is toward the front (bobbin case side), and (3) the scarf/scooped out part of the needle is toward the handwheel. The needle can sometimes be rotated to 5 o'clock (slightly right) or 7 o'clock (slightly left) in order to adjust for a more positive thread loop pickup by the hook point.</li>   <li>• Loosen top tension. Re-check top and bobbin tension (see pages 19-20).</li> <li>• Inspect that the thread take-up lever, thread stirrup or tension spring are all threaded correctly.</li> </ul>
The Needle Breaks	Corrective Measure
<ul style="list-style-type: none"> <li>• The needle is bent or not installed properly</li>   <li>• The needle hits the needle plate</li> </ul>	<ul style="list-style-type: none"> <li>• Replace or correctly change the needle. Make sure that the needle is pushed up into the needle bar clamp until it can go no farther (visually check that it is up to the top of the stop/sight hole above the needle bar clamp screw). Failure to do so can cause damage in the bobbin area and throat plate.</li> <li>• Correctly position the needle, needle plate or hopping foot. Replace needle with a new one.</li> </ul>
Stitches are Puckered	Corrective Measure
<ul style="list-style-type: none"> <li>• Tension is not balanced</li>   <li>• Needle too large for material</li> </ul>	<ul style="list-style-type: none"> <li>• Balance the tension of the needle thread after ensuring the bobbin tension is adjusted correctly (see pages 19-20).</li> <li>• Replace the needle with a size better suited to the fabric.</li> </ul>

## Correcting Common Issues

Stitch Quality is Poor	Corrective Measure
<ul style="list-style-type: none"> <li>Tension is not balanced</li> <li>Bobbin case is damaged, corroded, dirty, et cetera</li> <li>Moving the fabric or depressing the foot pedal inconsistently</li> </ul>	<ul style="list-style-type: none"> <li>Adjust the tension of the needle thread after ensuring the bobbin tension is adjusted correctly (see pages 19-20).</li> <li>Since thread slides over the surface of the bobbin case at a high speed, make sure the case is free of any lint or foreign matter that could impede thread passage through the machine.</li> <li>The My Speed setting should be adjusted to a value that will allow you to sew comfortably and confidently with the foot pedal fully depressed. Discover a method of holding the fabric that is most comfortable.</li> </ul>
Tension Is Poor	Corrective Measure
<ul style="list-style-type: none"> <li>Lint caught under the tension spring in the bobbin case</li> <li>Poorly wound bobbin</li> </ul>	<ul style="list-style-type: none"> <li>With some threads, lint and other material can build up under the tension leaf spring and begin to lift the spring. This reduces the spring's ability to compress against the thread. By inserting a needle under the spring and clearing out the lint, the bobbin tension will return to the previously set tension.</li> <li>If the bobbin is wound too tight or too loose it can lead to poor and inconsistent tension. Make sure when the bobbin is wound that the thread tension is not so tight that the wound bobbin thread feels hard and causes the bobbin sides to bulge. It should also not be so loose that the thread is spongy, which can cause the thread to tangle as it is wound.</li> </ul>
Hand Wheel Won't Rotate	Corrective Measure
<ul style="list-style-type: none"> <li>Thread is entangled and caught in the hook</li> </ul>	<ul style="list-style-type: none"> <li>Turn off the machine and remove the power plug from the electrical outlet. Remove the bobbin case from the machine. Lubricate the hook, then manually rotate the hand wheel clockwise and counter-clockwise several times. Remove the thread caught in the hook.</li> </ul>
Thread Nests Under Quilt	Corrective Measure
<ul style="list-style-type: none"> <li>Not enough tension on top thread</li> <li>Improper threading</li> </ul>	<ul style="list-style-type: none"> <li>Check that the machine is threaded correctly. Make certain that the thread is flossed snugly in place between the two tension discs. If the machine is correctly threaded, tighten the top tension by rotating the tension knob clockwise.</li> <li>Refer to the threading diagram and threading instructions on pages 16-17.</li> </ul>
Motor Fails to Run	Corrective Measure
<ul style="list-style-type: none"> <li>On/Off switch is off or power cord is loose</li> <li>Foot pedal is unplugged</li> </ul>	<ul style="list-style-type: none"> <li>Turn the machine on only by using the switch on the back of the power pod. Verify the power cord is plugged in tightly at both the machine and the power source.</li> <li>Verify that the foot pedal is plugged in. If the main screen status message in the upper left hand corner says "Check Pedal", then the pedal is not properly installed.</li> </ul>

## Correcting Common Issues

Needle Thread Breaks	Corrective Measure
<ul style="list-style-type: none"> <li>• Top and bobbin tension not balanced</li> <li>• Thread cones/spools are poor quality or may have severe twisting or thread rot</li> <li>• The machine head has been threaded incorrectly or thread spools are not positioned correctly</li> <li>• Particles in tension discs</li> <li>• Bobbin rotation is not smooth</li> <li>• Needle is burred, bent or dull, or installed incorrectly</li> <li>• Needle not suited for the thread</li> <li>• Hesitating too long at one point in the pattern</li> <li>• Improper needle/hook relationship</li> <li>• Damage or burr at the needle hole in the needle plate or any other place along the thread path</li> <li>• Wrong type of needle</li> <li>• Other possible causes:</li> </ul>	<ul style="list-style-type: none"> <li>• Check the tension of the top tensioner and bobbin for proper balance (see pages 19-20).</li> <li>• Look for severe twisting of threads when approximately 12 to 15 inches has been pulled off, with ends pinched together. Cotton threads are particularly susceptible to dry rot which makes thread brittle. Do not use poor quality thread, or thread that is rotted or brittle.</li> <li>• Check that the machine is threaded correctly.</li> <li>• Inspect for accidental double wrapping of thread on thread guides.</li> <li>• Inspect the thread stand making sure the eyelets of the stand are directly over the spools.</li> <li>• Inspect the vertical positioning of the thread cones. Tipped cones can dramatically affect thread tension and can cause breakage.</li> <li>• Inspect for particles and remove any lint or debris.</li> <li>• Change the bobbin. The slightest hesitation of the bobbin rotation can be the cause of dramatic tension change and thread breakage. Use ONLY INSPIRA® bobbins</li> <li>• Change the needle at least once per quilt. Make sure the needle is installed to the top of the sight hole in the needle bar.</li> <li>• Replace the needle with one better suited for the thread. Use the proper size needle.</li> <li>• Move more quickly so stitches don't overlap or build up. When starting the machine, begin moving immediately. Sewing in one place too long will cause the thread to break.</li> <li>• Timing of the machine is improper. Consult a repair technician at your local, authorized HUSQVARNA VIKING® representative.</li> <li>• If the thread is shredding at the needle plate, check for burrs or jagged edges. Gently rub with metal cloth to remove the sharp edge. Consult a repair technician to polish any hard to reach or delicate areas, or if the burr is inside the hole.</li> <li>• Use needles recommended by HUSQVARNA VIKING®. Using the wrong needle with a smaller shank diameter causes many problems. For example a system 1738 or 287WH needle with a shank diameter of 1.64mm will fit loosely into the clamp at an angle. This may cause skipped stitches because the needle is positioned too far away from the hook point. It can also cause the needle to hit the hook, breaking the needle.</li> <li>• The needle is too close to the hook, which causes friction and a possible collision of the hook point and the needle.</li> <li>• Needle plate damage.</li> <li>• Hook damage.</li> <li>• Broken needle inside needle bar clamp, preventing the needle from insertion to the top of the clamp.</li> <li>• Damaged needle bar clamp.</li> </ul>
No Visible Display	Corrective Measure
<ul style="list-style-type: none"> <li>• Cable unplugged</li> </ul>	<ul style="list-style-type: none"> <li>• Check the communication cable that connects the display to the machine and make sure the connection is secure.</li> </ul>

## Optional Accessories

### INSPIRA® Horizontal Spool Pin



Figure 35

An optional horizontal spool pin is available for use with delicate threads such as metallics or holographic threads or for specialty threads that are wound on a spool (not a cone). Some threads twist and break if fed from a vertical spool.

### INSPIRA® Table Extension



Figure 37

Expand your original PLATINUM™ 16 quilting machine table with Table Extensions. Each extension measures 18" x 30". Purchase one or two to provide extra support for large projects. Adding two extensions will expand the original table to a full six feet in width (one extension shown above).

### TruStitch™ Stitch Regulator for HUSQVARNA VIKING®



Figure 36

Innovative stitch-regulation system enables you to create even, harmonious stitches regardless of stitching speed.

### INSPIRA® Table Overlay

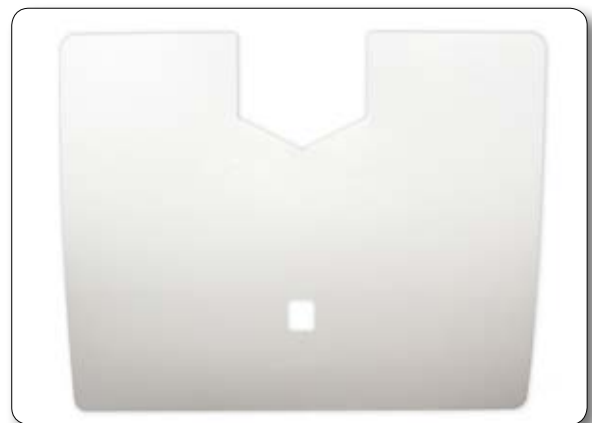

Figure 38

Attached to the table to create a continuous surface for use with the Stitch Regulator.



# Register your PLATINUM™ I6 Quilting Machine

For product and warranty registration, go to the HUSQVARNA VIKING® web site at [www.husqvarnaviking.com](http://www.husqvarnaviking.com).

## Correct Disposal of this Product



This marking indicates that this product should not be disposed with other household wastes throughout the European Union. To prevent possible harm to the environment or human health from uncontrolled waste disposal, recycle it responsibly to promote the sustainable reuse of material resources. To return your used device, please use the return and collection systems or contact the retailer where the product was purchased. They can take this product for environmental safe recycling.

### CE - Authorised Representative

VSM Group AB, SVP Worldwide

Drottninggatan 2, SE-56184, Huskvarna, SWEDEN



[www.husqvarnaviking.com](http://www.husqvarnaviking.com)

© 2013 KSIN Luxembourg II, S.ar.l. All rights reserved.