

*TWO NEEDLE DOUBLE CHAIN
LOCKSTITCH SEWING MACHINE*

GK 0058
PARTS BOOK

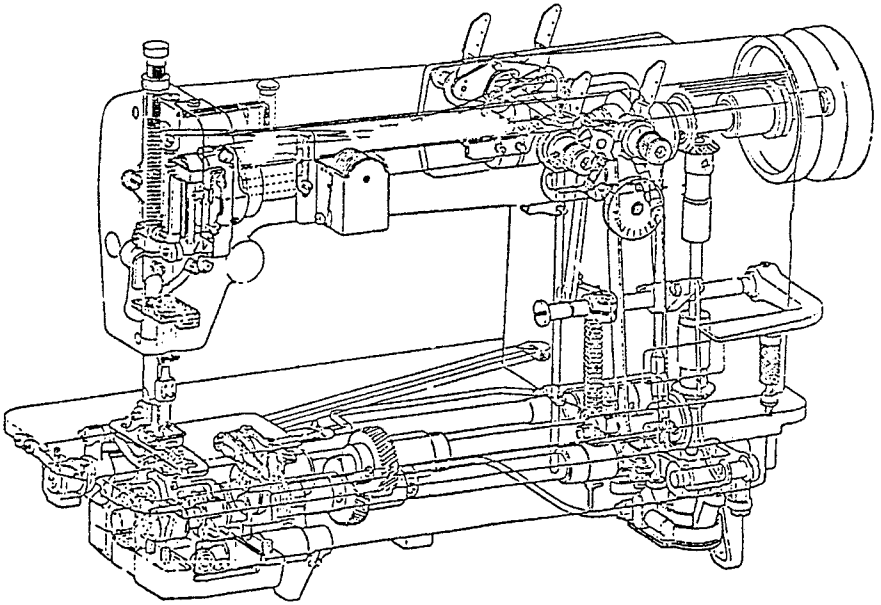

ARM & BED MECHANISM

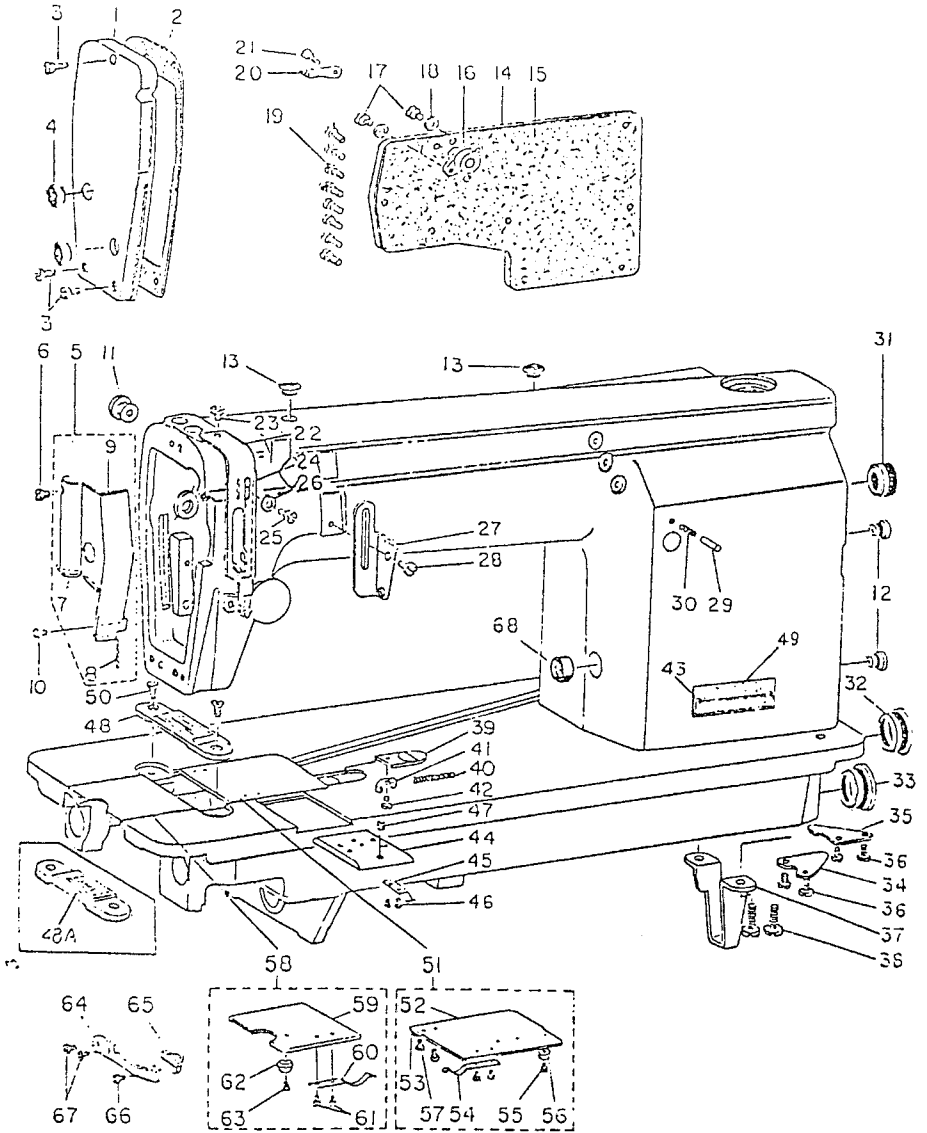

ARM & BED MECHANISM

No.	Part Number	Description	Q'ty	Remarks
1	5S1-12	Face plate	1	
2	5S1-13	Gasket	1	
3	22T1-004	Screw	3	
4	22T1-003C4	Rubber plug	2	
5	5S1-018D	Oil wick holder assy	1	
6	5S1-04	Screw	1	
7	5S1-018D2	Oil braid for needle bar	1	
8	5S1-018D3	Oil wick for needle bar	1	
9	5S1-018D1	Oil wick holder	1	
10	22T2-004	Screw	1	
11	22T1-003C4	Rubber plug	1	
12	22T1-015	Rubber plug	2	
13	22T1-003C4	Rubber plug	2	
14	5S1-19	Side cover	1	
15	5S1-20	Gasket for side cover	1	
16	5S1-27E	Bushing assy for thread releasing	1	
17	5S1-28	Screw	2	
18	5S1-29	Washer	2	
19	22T1-004	Screw	8	
20	5S1-21	2-eyed thread guide	1	
21	22T2-004	Screw	1	
22	5S1-15	Cover plate for thread take-up	1	
23	22T2-004	Screw	2	
24	5S1-14	Tensioner for thread take-up	1	
25	22T2-004	Screw	1	
26	22T1-007	Washer	1	
27	5S1-16	Inter-thread-guide	1	
28	22T2-019	Screw	1	
29	5S4-27	Stop pin	1	
30	5S4-26	Stop pin spring	1	
31	5S1-17	Rubber plug	1	
32	5S1-32	Rubber plug	1	
33	5S1-32	Rubber plug	1	
34	5S1-26	Front oil shield	1	
35	5S1-33	Back oil shield	1	
36	22T2-004	Screw	4	

ARM & BED MECHANISM

No.	Part Number	Description	Q' ty	Remarks
37	5S1-31	Bracket	1	
38	5S1-30	Screw	2	
39	5S1-02	Opener for right slide plate	1	
40	5S1-03	Opener spring	1	
41	5S1-05	Backing plate	1	
42	5S1-04	Screw	1	
43	22T1-002B3	Rivet	2	
44	5S1-06	Adjusting plate	1	
45	5S1-08	Lock spring	1	
46	J9. 0. 3	Screw	2	
47	5S1-07	Set Screw	1	
48	5S1-10	Needle plate 1/4"	1	
49	5S1-25	Name plate	1	
50	J0. 0. 27	Screw	2	
51	5S1-09B	Right slide plate assy.	1	
52	5S1-09B1	Right slide plate	1	
53	5S1-09B4	Position plate	1	
54	5S1-09B3	Position spring	1	
55	61. 04. 01/B7/Z1	Screw	1	
56	5S1-09B2	Lock ring	1	
57	J9. 0. 3	Screw	4	
58	5S1-11C	Left slide plate assy.	1	
59	5S1-11C1	Left slide plate	1	
60	5S1-11C2	Position spring	1	
61	J9. 0. 3	Screw	2	
62	5S1-11C3	Lock ring	1	
63	61. 04. 01/B7/Z1	Screw	1	
64	5S1-24	Opener spring	1	
65	5S1-23	Opener for left slide plate	1	
66	6A2-14	Screw	1	
67	22T2-004	Screw	2	
48A	5S1-10-3	Needle plate	1	Tandem

ARM SHAFT AND NEEDLE BAR MECHANISM

No.	Part Number	Description	Q'ty	Remarks
1	TVX7 #14	Needle	2	
2	5S2-4	Needle bar bushing (lower)	1	
3	5S2-2	Needle clamp	1	
4	22T2-013	Screw	2	
5	5S8-5	Screw	1	
6	22T2-012C2	Thread guide	1	
7	5S2-3	Needle bar	1	
8	5S2-22	Machine pulley	1	
9	5S2-6	Needle bar adaptor	1	
10	22T2-001A9	Screw	1	
11	5S2-1	Slide block	1	
12	5S2-25	Bracket for thread take-up	1	
13	5S2-26	Screw	1	
14	5S2-20B3	Self-lock spring	1	
15	5S2-24	Thread take-up lever	1	
16	5S2-28	Tension plate	1	
17	5S2-27	Tension spring	1	
18	5S2-29	Tension screw	1	
19	22T2-001A9	Screw	2	
20	5S2-11	Needle bar bushing (upper)	1	
21	5S2-10	Screw	1	
22	22T2-011	Rubber plug	1	
23	22T3-007C2	Screw	2	
24	5S2-16	Arm shaft	1	
25	5S2-8	Adjusting valve for oil amount	1	
26	GB3452.1-82	O-ring	1	
27	5S2-13	Felt	1	
28	5S2-7	Hinge stud	1	
29	5S2-12	Needle bar crank	1	
30	J0.0.81	Screw	1	
31	22T2-007	Set Screw	1	
32	5S2-23	Screw	1	
33	GB3452.1-82	O-ring	1	
34	5S2-5	Connecting rod	1	
35	10242/S	Needle bearing	1	
36	22T2-001A6	Screw	1	

ARM SHAFT AND NEEDLE MECHANISM

No.	Part Number	Description	Q' ty	Remarks
37	5S2-15	Bushing (left)	1	
38	J0.040	Screw	1	
39	5S2-18	Bushing (middle)	1	
40	J0.040	Screw	1	
41	5S2-17	Stop ring	2	
42	22T2-005B3	Set Screw	4	
43	5S2-19	Bushing (right)	1	
44	5S2-19A1	Outer ring	1	
45	5S2-19A3	Bearing needle and retainer assy.	2	
46	5S2-19A2	Retaining ring	2	
47	GB893.1-86-21	Stop ring	2	
48	5S2-20	Rubber ring	1	
49	5S2-9	Seal ring	1	
50	5S2-14	Oil wick	1	
3A	5S2-2-3	Needle clamp	1	Tandem

PRESSER BAR, VERTICAL SHAFT AND LOWER SHAFT MECHANISM

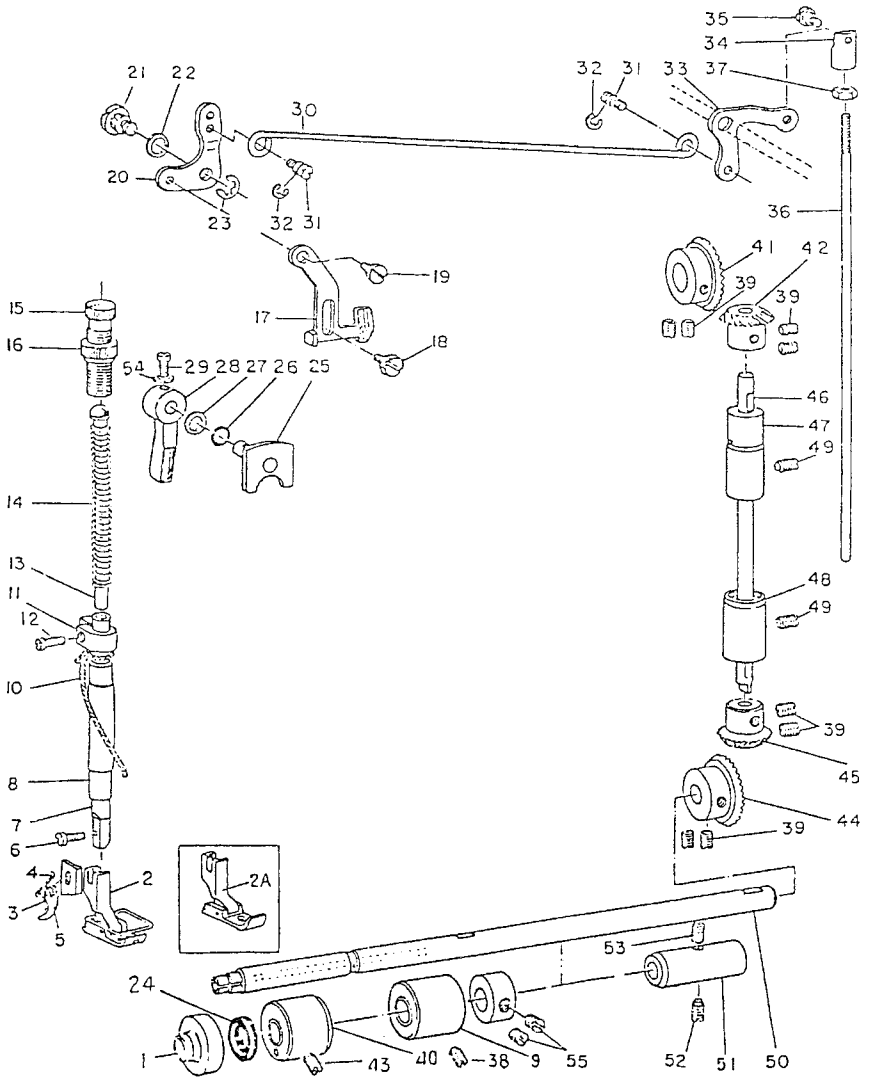

PRESSER BAR, VERTICAL SHAFT AND LOWER SHAFT MECHANISM

No.	Part Number	Description	Q'ty	Remarks
1	5S3-33	Bushing	1	
2	5S3-23B	Presser foot assy.	1	
3	5S3-24	Thread cutter	1	
4	5S3-16	Thread cutter guide	1	
5	6A1-a04	Screw	1	
6	22T7-015	Screw	1	
7	5S3-22	Presser bar	1	
8	5S3-21	Bushing	1	
9	5S3-30	Bushing (middle)	1	
10	5S3-20	Oil wick	1	
11	5S3-19	Presser bar guide	1	
12	J0. 0. 45	Screw	1	
13	22T7-012	Guide stud	1	
14	22T7-013	Presser bar spring	1	
15	22T7-014E1	Adjusting stud	1	
16	22T7-014E2	Thumb nut	1	
17	5S3-1	Presser foot lifting bracket	1	
18	5S3-2	Screw	1	
19	5S3-3	Screw	1	
20	5S3-5	Knee lifter lever (left)	1	
21	5S3-10	Screw	1	
22	5S3-9	Washer	1	
23	GB894-76	Stop ring 7	1	
24	5S3-32	Oil seal	1	
25	5S3-13A	Presser bar lifting cam assy.	1	
26	GB3452.1-82	O-ring	1	
27	5S3-14	Washer	1	
28	5S3-15	Presser foot lifter lever	1	
29	6A2-27	Screw	1	
30	5S3-6	Knee lifting rod	1	
31	5S3-4	Screw	2	
32	GB894-76	Stop ring 6	2	
33	5S3-7	Knee lifting lever (right)	1	
34	5S3-8	Connection joint	1	
35	5S3-35	Screw	1	
36	5S3-28	Connecting rod	1	

PRESSER BAR, VERTICAL SHAFT AND LOWER SHAFT MECHANISM

No.	Part Number	Description	Q'ty	Remarks
37	22T6-001A8	Nut	1	
38	22T2-002	Screw	1	
39	22T2-005B3	Set Screw	8	
40	5S3-31	Bushing (left)	1	
41	22T3-010E2a1	Bevel gear	1	
42	22T3-010E2a2	Bevel gear	1	
43	22T2-002	Screw	1	
44	22T3-010E2a1	Bevel gear	1	
45	22T3-010E2a1	Bevel gear	1	
46	5S3-18	Vertical shaft	1	
47	5S3-11	Bushing (upper)	1	
48	5S3-17	Bushing (lower)	1	
49	22T2-002	Screw	2	
50	5S3-34	Lower shaft	1	
51	5S3-26	Bushing (right)	1	
52	22T2-002	Screw	1	
53	5S3-27	Felt	1	
54	5S3-12	Washer	1	
55	22T2-005B3	Set Screw	2	
2A	5S3-23B-3	Presser foot assy.	1	Tandem

STITCH REGULATING MACHANISM

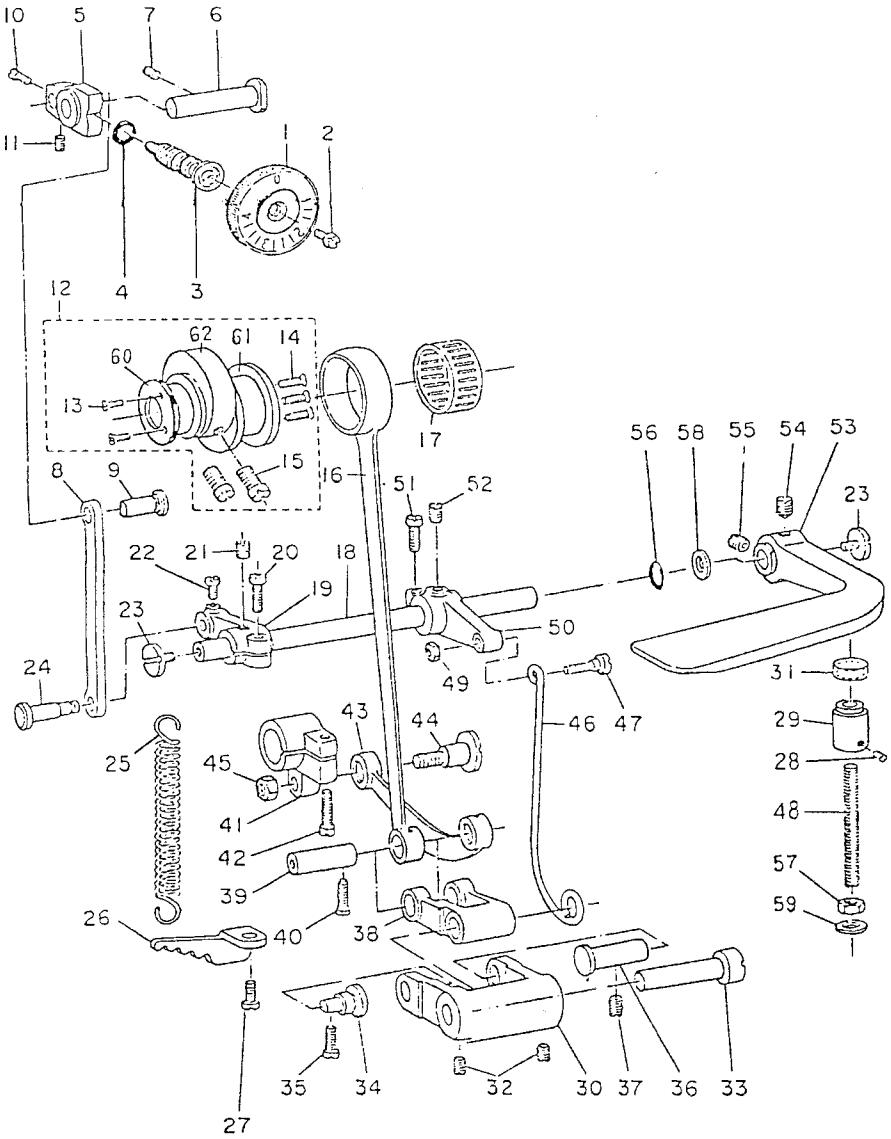

STITCH REGULATING MECHANISM

No.	Part Number	Description	Q' ty	Remarks
1	5S4-28	Dial	1	
2	5S4-30	Screw	1	
3	5S4-29K1	Regulating screw	1	
4	GB1235	O-ring	1	
5	5S4-11D2	Stitch regulating block	1	
6	5S4-12	Pin	1	
7	2J2-002	Screw	1	
8	5S4-14	Stitch regulator link	1	
9	5S4-13	Pin	1	
10	5S4-11D1	Screw	1	
11	5S4-11D2	Screw	1	
12	5S4-18G	Feed cam assy.	1	
13	5S4-18G6	Screw	2	
14	5S4-18G1	Screw	3	
15	5S4-18G4	Screw	2	
16	5S4-20	Feed connection rod	1	
17	9241/23	Bearing	1	
18	5S4-231	Lever shaft	1	
19	5S4-15E2	Front crank	1	
20	5S4-15E1	Screw	1	
21	61-04-01/B3	Screw	1	
22	5S4-15E3	Screw	1	
23	5S4-24	Screw	2	
24	5S4-16	Pin	1	
25	5S4-46	Spring	1	
26	5S4-47	Hanger	1	
27	5S4-48	Screw	1	
28	2113-003	Screw	1	
29	5S4-32M2	Stopper bushing	1	
30	5S4-55T1	Crank	1	
31	5S4-32M1	Rubber ring	1	
32	5S4-04C2	Screw	2	
33	5S4-54	Long pin	1	
34	5S4-51	Short pin	1	
35	5S4-48	Screw	1	
36	5S4-54	Long pin	1	

STITCH REGULATING MECHANISM

No.	Part Number	Description	Q'ty	Remarks
37	J0.081	Screw	1	
38	5S4-53	Feed driving rock arm	1	
39	5S4-52	Pin	1	
40	22T6-008D3	Screw	1	
41	5S4-45R1	Feed crank	1	
42	61-04-01/B5	Screw	1	
43	5S4-49	Feed rocker	1	
44	5S4-42	Pin	1	
45	5S4-43	Nut	1	
46	5S4-22	Pull bar	1	
47	5S4-21H2	Pin	1	
48	5S4-32M3	Screw bar	1	
49	5S4-21H3	Nut	1	
50	5S4-21H1	Back crank	1	
51	5S4-15E1	Screw	1	
52	61-04-01/B3	Screw	1	
53	5S4-31L3	Lever	1	
54	5S4-31L2	Screw	1	
55	5S4-31L1	Screw	1	
56	GB1235	O-ring	1	
57	5S4-33	Nut	1	
58	GB95	Washer 10	1	
59	5S4-34	Washer	1	
60	5S4-18G2	Small spacer	1	
61	5S4-18G5	Big spacer	1	
62	5S4-18G3	Feed cam	1	

FEED & FEED LIFTING MECHANISM

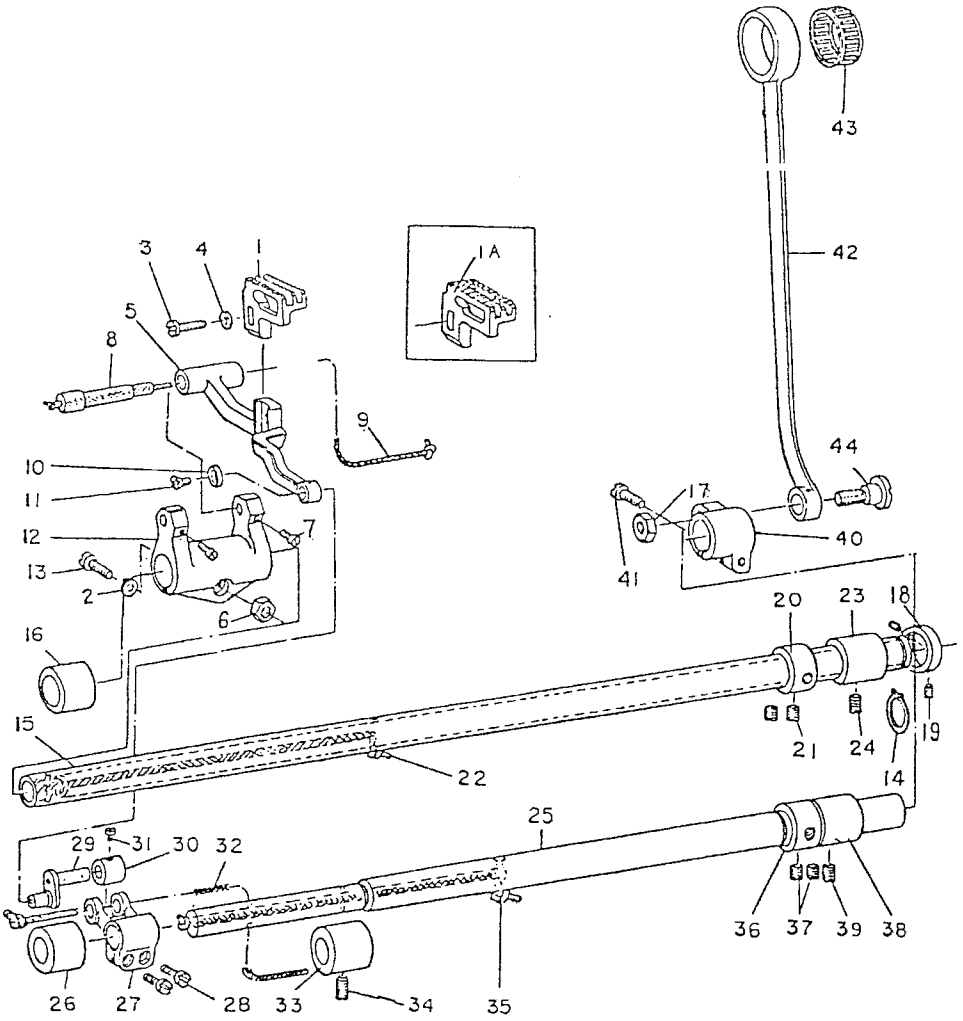

FEED & FEED LIFTING MECHANISM

No.	Part Number	Description	Q'ty	Remarks
1	5S4-07	Feed dog	1	
2	5S4-08	Washer	1	
3	5S4-09	Screw	1	
4	5S4-08	Washer	1	
5	5S4-02	Feed bar	1	
6	5S4-21H3	Nut	1	
7	6A1-08	Screw	2	
8	5S4-37P1	Crank shaft	1	
9	5S4-37P2	Oil wick	1	
10	5S4-06	Washer	1	
11	5S4-05	Screw	1	
12	5S4-36N2	Crank	1	
13	5S4-36N1	Screw	1	
14	GB894	Stop ring 15	1	
15	5S4-50S1	Feed rock shaft	1	
16	5S4-35	Front bushing	1	
17	5S4-43	Nut	1	
18	5S4-25J1	Narrow collar	1	
19	J0.068	Screw	2	
20	5S4-40Q1	Stop ring	1	
21	22T2-00B2	Screw	2	
22	5S4-5S2	Oil wick	1	
23	5S4-44	Back bushing	1	
24	J0.081	Screw	1	
25	5S4-39	Feed lifting rock shaft	1	
26	5S4-10	Front bushing	1	
27	5S4-01A1	Feed lifting crank (left)	1	
28	5S4-01A2	Screw	2	
29	5S4-03B1	Feed lifting link	1	
30	5S4-04C1	Stop ring	1	
31	5S4-04C2	Screw	2	
32	5S4-03B2	Oil wick	1	
33	5S4-10	Front bushing	1	
34	J0.040	Screw	1	
35	5S4-38	Oil wick	1	
36	5S4-40Q1	Stop ring	1	

FEED & FEED LIFTING MECHANISM

No.	Part Number	Description	Q'ty	Remarks
37	22T3-002B2	Screw	2	
38	5S4-44	Back bushing	1	
39	J0.081	Screw	1	
40	5S4-17F1	Feed lifting crank (right)	1	
41	61-04-01/B5	Screw	1	
42	5S4-19	Feed lifting connecting rod	1	
43	9241/24	Bearing	1	
44	5S4-42	Pin	1	
1A	5S4-07-3	Feed dog	1	Tandem

LOOPER MECHANISM

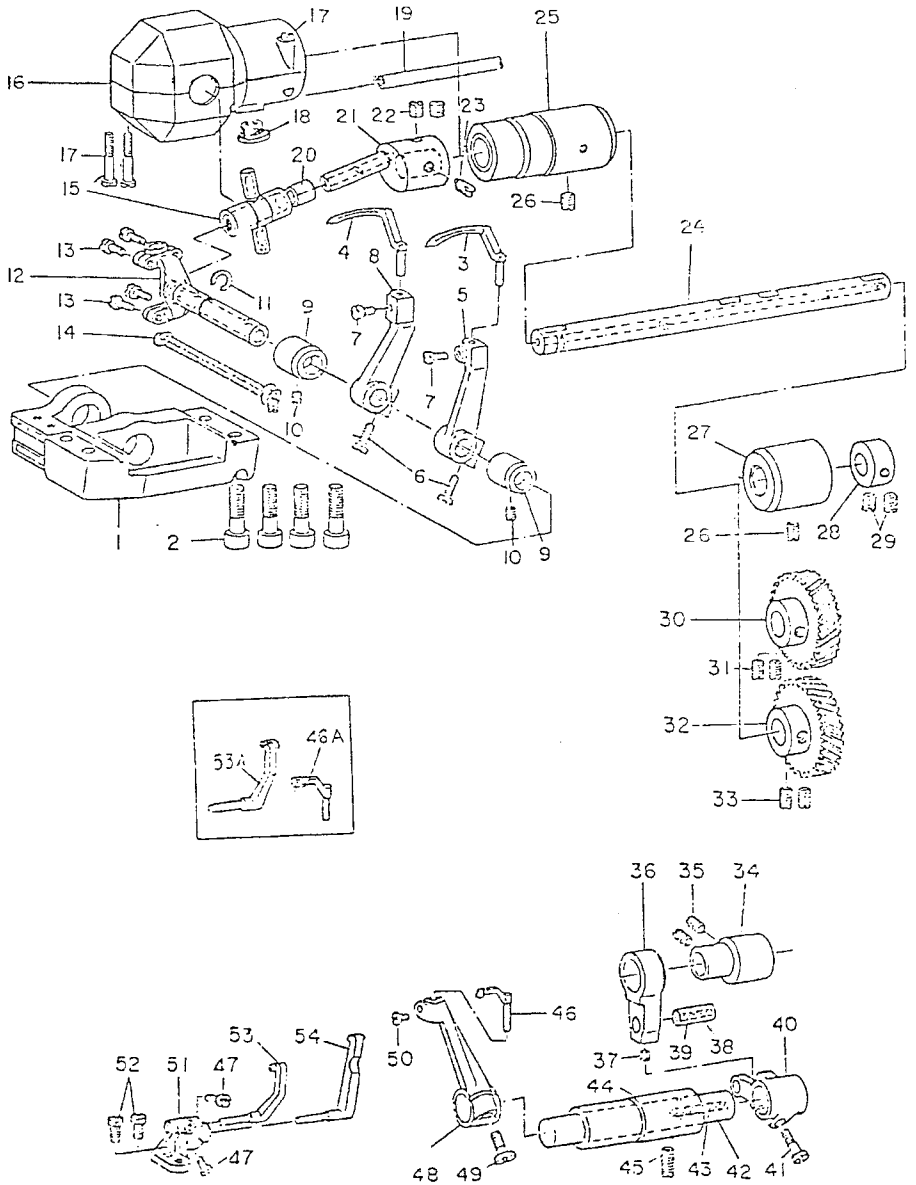

LOOPER MECHANISM

No.	Part Number	Description	Q' ty	Remarks
1	5S5-01	Looper base	1	
2	5S5-02	Screw	4	
3	5S5-30	Left looper	1	
4	5S5-31	Right looper	1	
5	5S5-28	Left looper bracket	1	
6	J0. 0. 71	Screw	2	
7	61-04-01/B3	Screw	2	
8	5S5-29	Right looper bracket	1	
9	5S5-04	Bushing	2	
10	61-04-01/B4/Z1	Screw	2	
11	GB894-2-86	Stop ring	1	
12	5S5-03A	Half shaft assy.	1	
13	6A2-23	Screw	4	
14		Yarn braid	1	
15	5S5-07	Cross joint	1	
16	5S5-05B	Looper crank housing assy.	1	
17	5S5-05B2	Screw	3	
18	22T1-003C4	Rubber plug	1	
19		Oil returning pipe	1	
20	5S5-08	Bushing	2	
21	5S5-09	Looper crank	1	
22	6A6-08A	Screw	2	
23	5S5-10	Eccentric stud	1	
24	5S5-11	Looper driving shaft	1	
25	5S5-12	Front bushing	1	
26	61-04-01/B9	Screw	2	
27	5S5-13	Back bushing	1	
28	5S5-14	Collar	1	
29	6A6-08A	Screw	2	
30	5S5-20	Left turn gear	1	
31	6A6-08A	Screw	2	
32	5S5-19	Right turn gear	1	
33	6A6-08A	Screw	2	
34	5A5-18	Needle protecting cam	1	
35	6A6-08A	Screw	2	
36	5S5-17	Needle protecting crank	1	

LOOPER MECHANISM

No.	Part Number	Description	Q'ty	Remarks
37	61-04-01/B4/Z1	Screw	1	
38	5S5-16	Pin	1	
39		Yarn braid	1	
40	5S5-15	Fork crank	1	
41	22T6-008D3	Screw	1	
42	5S5-22	Needle protecting shaft	1	
43		Yarn braid	1	
44	5S5-21	Bushing	1	
45	61-04-01/B3	Screw	1	
46	5S5-24	Movable needle protecting lever	1	
47	61-04-01/B3	Screw	2	
48	5S5-23	Needle protecting bracket	1	
49	22T6-001A16	Screw	1	
50	J0. 0. 42	Screw	1	
51	5S5-27	Needle protecting base	1	
52	22T2-019	Screw	2	
53	5S5-25	Needle protecting lever (left)	1	
54	5S5-26	Needle protecting lever (right)	1	
46A	5S5-24-3	Needle guard block	1	Tandem
53A	5S5-25-3	Needle guard block	1	Tandem

THREAD TENSION MECHANISM

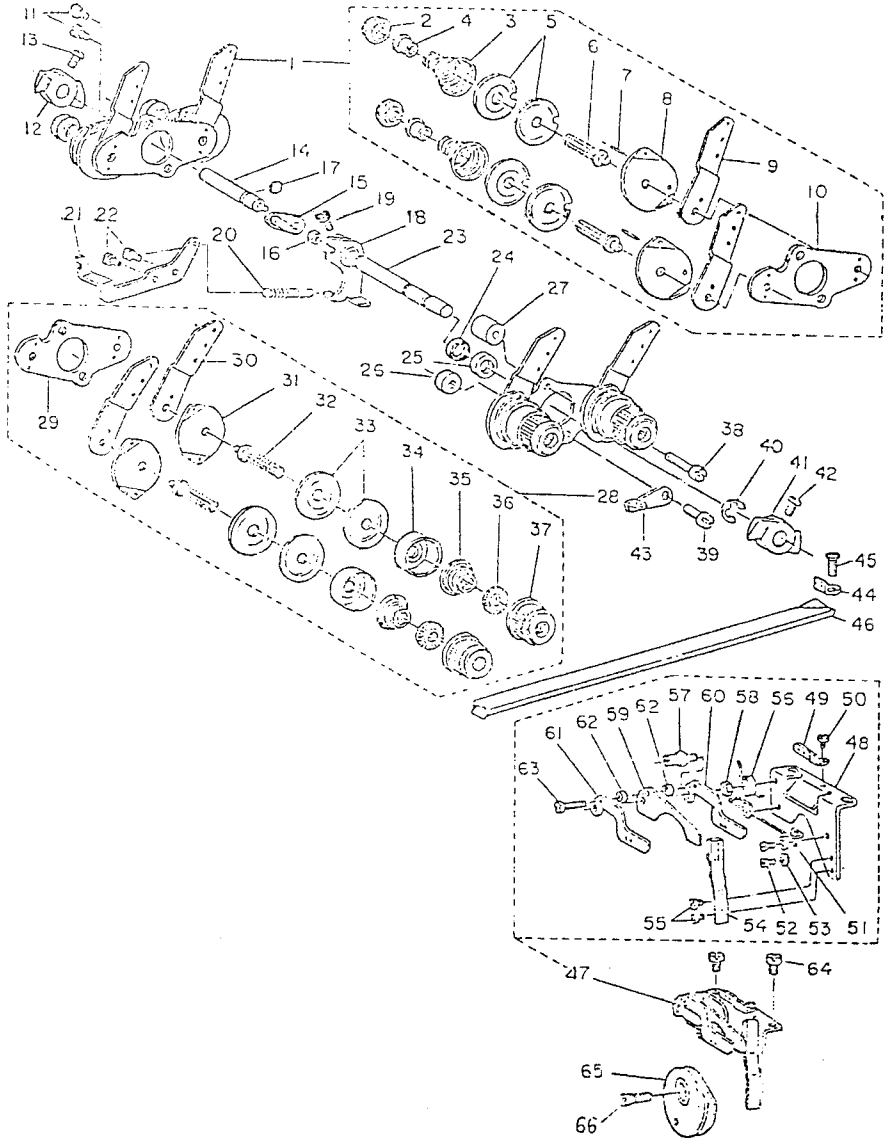

THREAD TENSION MECHANISM

No.	Part Number	Description	Q'ty	Remarks
1	5S6-01A	Rear thread tension assy.	1	
2	5S6-01A8	Tension nut	2	
3	5S6-01A6	Tension spring	2	
4	5S6-01A7	Retaining ring	2	
5	5S6-01A5	Tension disc	4	
6	5S6-01A1	Tension stud	2	
7	GB879-86	Pin	2	
8	5S6-01A4a1	Eyed thread guide plate	2	
9	5S6-01A3	3-eyed thread guide plate (rear)	2	
10	5S6-01A2	Installation plate	1	
11	36T5-008E5	Screw	2	
12	5S6-02	Thread releasing cam (rear)	1	
13	6A3-18	Screw	1	
14	5S6-03B1	Thread releasing stud (rear)	1	
15	5S6-03B2, B4	Thread releasing pin (rear)	1	
16	5S6-03B3	Nut	1	
17	GB3452. 1-82	O-ring	1	
18	5S6-04C2	Thread releasing fork	1	
19	36T5-008E5H01	Screw	1	
20	5S6-15	Spring	1	
21	5S6-14	Suspension lever	1	
22	22T1-004	Screw	2	
23	5S6-05	Shaft	1	
24	GB3452. 1-82	O-ring	1	
25	5S6-10	Bushing	1	
26	5S6-06	Bushing	1	
27	5S6-08	Bushing	1	
28	5S6-13D	Front thread tension assy.	1	
29	5S6-01A2	Installation plate	1	
30	5S6-13D1	3-eyed thread guide plate (front)	2	
31	5S6-13D2	Thread guide plate	2	
32	5S6-01A1	Tension stud	2	
33	5S6-13D3	Tension disc	4	
34	5S6-13D4	Tension spring cap	2	
35	5S6-13D5	Tension spring	2	
36	5S6-13D6	Retaining ring	2	

THREAD TENSION MECHANISM

No.	Part Number	Description	Q'ty	Remarks
37	5S6-13D7a	Tension nut	2	
38	5S6-09	Screw	1	
39	5S6-07	Screw	1	
40	5S6-11	Spring stop ring	1	
41	5S6-12	Thread releasing cam (front)	1	
42	6A3-18	Screw	1	
43	5S1-21	2-eyed thread guide	1	
44	5S6-16	Thread guide at bed	1	
45	5S6-17	Screw	1	
46	5S6-18	Thread guide trough	1	
47	5S6-21F	Thread releasing bracket assy.	1	
48	5S6-21F9	Thread guide plate (big)	1	
49	5S6-21F7	Thread guide plate (small)	1	
50	5S6-21F8	Screw	1	
51	5S6-21F10	Spring	1	
52	6A2-14	Screw	2	
53	GB97. 2-85	Washer 3A	2	
54	5S6-21F11	Spring plate	1	
55	5S6-21F8	Screw	2	
56	5S6-21F6	Spring	1	
57	5S6-21F3	Screw	1	
58	5S6-03B3	Nut	1	
59	5S6-21F4	Thread retaining plate	1	
60	5S6-21F5	Thread guide (right)	1	
61	5S6-21F1	Thread guide (left)	1	
62	5S6-21F1	Bushing	2	
63	22T8-004	Screw	1	
64	N3-7-27	Screw	2	
65	5S6-20E	Thread releasing cam assy. (lower)	1	
66	5S6-19	Screw	1	

LUBRICATION MECHANISM

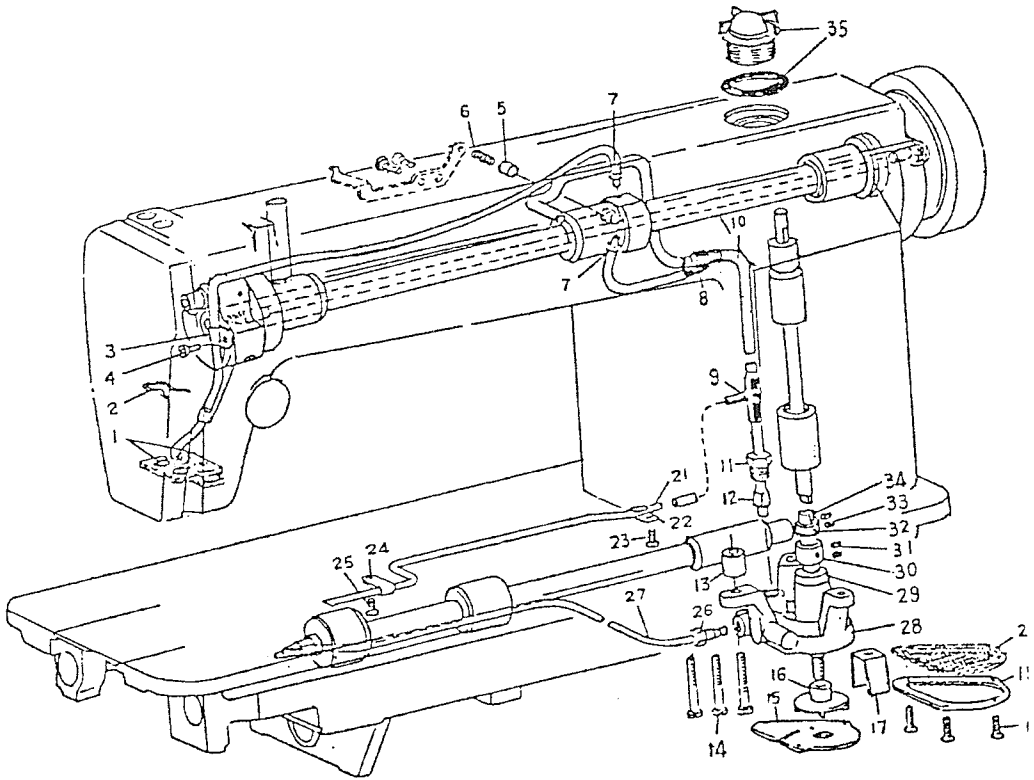

LUBRICATION MECHANISM

No.	Part Number	Description	Q' ty	Remarks
1	5S7-01A3, A4	Felt	1	
2	5S7-05	Spring	1	
3	5S7-01A2	Oil sucking tube support	1	
4	36T5-008E5	Screw	1	
5	5S7-09	Pin	1	
6	5S7-08	Spring	1	
7	5S7-06	Joint	2	
8	5S7-07	Oil tube sleeve	1	
9	5S7-10A	Oil tube sleeve	1	
10	5S7-10	Main oil tube	1	
11	5S7-17E1	Nut	1	
12	5S7-17E2	Bush	1	
13	5S7-13	Bushing	3	
14	5S7-14	Screw	3	
15	5S7-22	Oil pump screen bracket	1	
16	5S7-18	Impeller	1	
17	5S7-23	Oil pump cover	1	
18	22T8-004	Screw	3	
19	5S7-21	Oil pump fitting plate	1	
20	5S7-20	Oil pump screen	1	
21	5S7-02	Oil tube	1	
22	5S7-04	Tube clamp	1	
23	36T5-008E5	Screw	1	
24	5S7-04	Tube clamp	1	
25	36T5-008E5	Screw	1	
26	5S7-03B2	Joint	1	
27	5S7-03B1	Oil tube	1	
28	5S7-19	Oil pump	1	
29	5S7-16	Bushing	1	
30	5S7-15D1	Collar (big)	1	
31	61-04-01/B4/E1	Screw	2	
32	5S7-12C	Collar (small)	1	
33	6A4-007B	Screw	2	
34	5S7-11	Oil pump shaft	1	
35	22T1-008H	Oil check window assy.	1	

OIL PAN MECHANISM

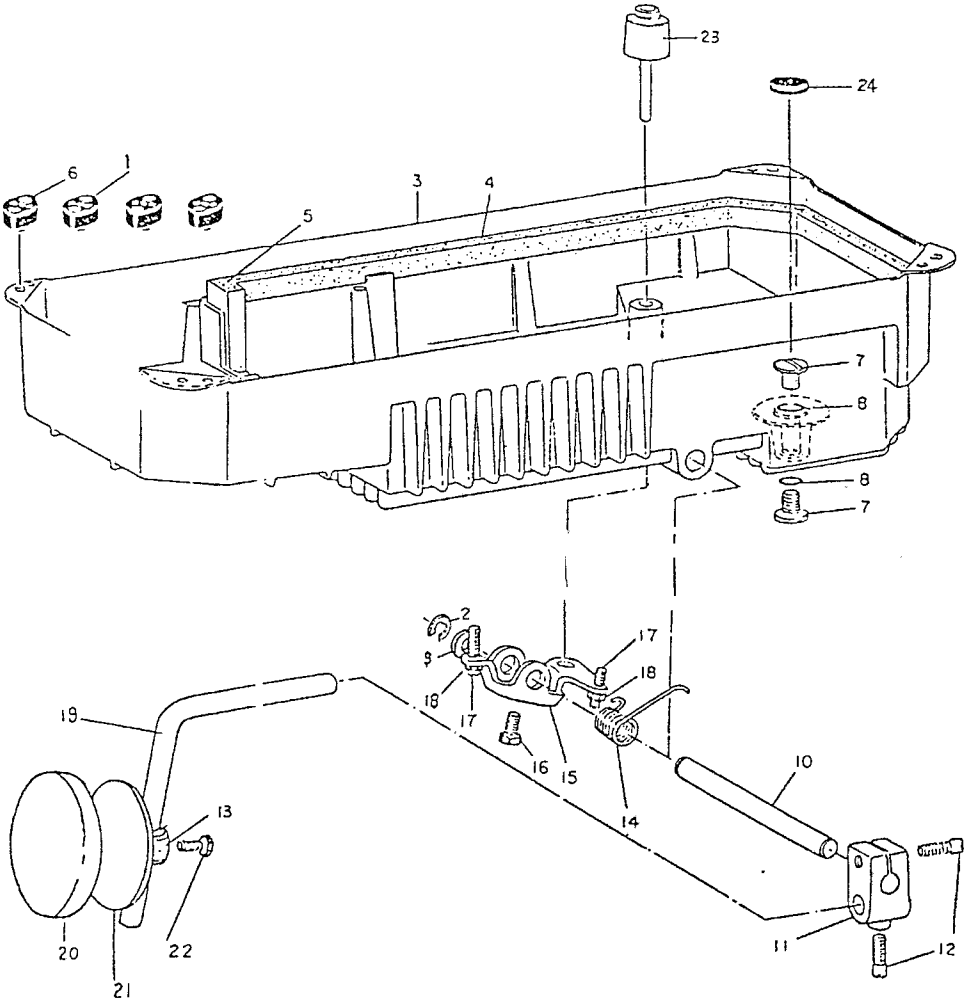

OIL PAN MECHANISM

No.	Part Number	Description	Q'ty	Remarks
1	22T9-010	Rubber cushion (small)	2	
2	GB894-76	Stop ring 11	1	
3	5S8-1	Oil pan	1	
4	5S8-2	Gasket (A)	2	
5	5S8-7	Gasket (B)	1	
6	22T9-009	Rubber cushion (big)	2	
7	5S8-5	Screw	2	
8	GB3452.1-82	O-ring	2	
9	GB95-85	Washer 10	1	
10	5S8-3	Hinge bar	1	
11	22T9-003B3	Joint	1	
12	22T9-003B4	Screw	2	
13	22T9-003B6	Bell crank bracket	1	
14	5S8-6	Spring	1	
15	22T9-001A8	Knee lifter stop bracket	1	
16	36T7-008D2	Screw	1	
17	22T9-001A9	Adjusting screw	2	
18	22T9-001A10	Nut	2	
19	22T9-003B2	Bell crank	1	
20	22T9-003B8	Pad	1	
21	22T9-003B5	Knee press plate	1	
22	22T9-003B7	Screw	1	
23	22T9-003B1	Lifting rod	1	
24	5S8-4	Magnet	1	

BELT GUARD & HEMMER DEVICE

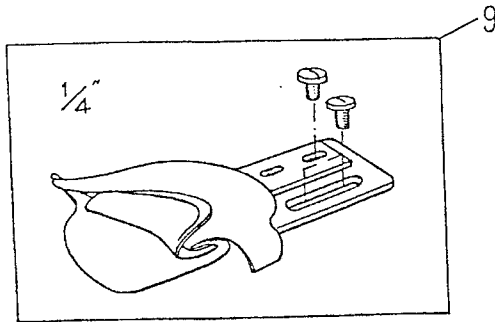
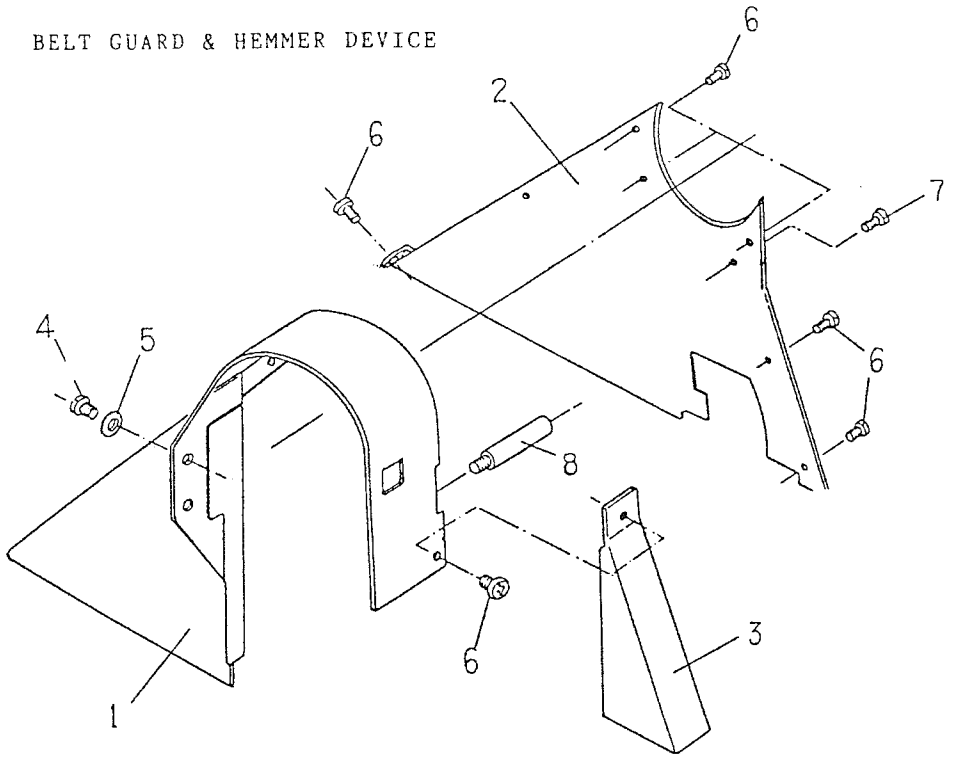

BELT GUARD & HEMMER DEVICE

No.	Part Number	Description	Q' ty	Remarks
1	5S10-1	Belt cover (big)	1	
2	5S10-2	Belt cover (middle)	1	
3	5S10-3	Belt cover (small)	1	
4	22T5-010D4	Set screw	1	
5	GB848-S5	Washer	1	
6	22T2-004	Screw	7	
7	22T2-019	Screw	1	
8	5S10-4	Stud	1	
9	5S11	Henmer 1/4"	1	

