

Commercial Dual Motor Upright Parts List

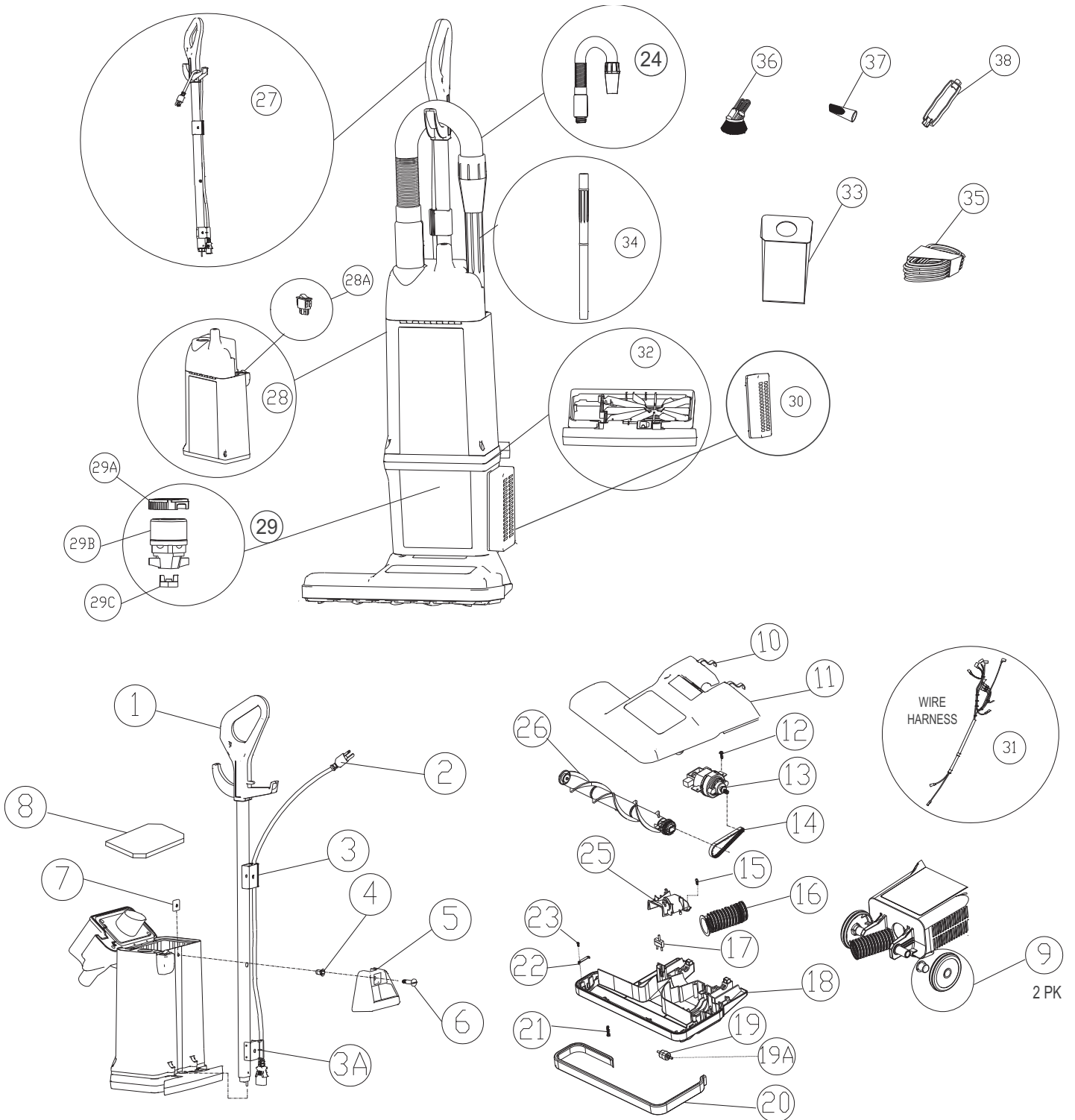

	PART NO.	DESCRIPTION
1	DM1	HANDLE GRIP
2	DM2	POWER CORD
3	DM3	UPPER CORD HOLDER WITH SCREW
3A	DM3A	LOWER CORD HOLDER WITH SCREW
4	DM4	SLEEVE FOR HANDLE BOLT
5	DM5	CARRY HANDLE
6	DM6	HANDLE BOLT
7	DM7	SQUARE HANDLE NUT
8	DM8	FOAM FILTER BELOW BAG
9	PPN60	REAR WHEELS WITH SLEEVE BEARING - 2 PCS EA./PACK
10	DM10	DETENT SPRING
11	DM11	PN HOOD WITH DETENT SPRINGS
12	DM12	SCREW-PN MOTOR
13	PPN17	BRUSH ROLL MOTOR
14	16-1982	BRUSH ROLL BELT
15	PPN14	DUCT HOSE TOP COVER SCREW
16	DM16	DUCT HOSE WITH CUFF ASSEMBLY
17	DM17	CIRCUIT BREAKER 1.6A WITH SPACER
18	DM18	BASE ASSEMBLY - COMPLETE WITH BUMPER AND ROLLER GUIDE
19	PPN22	FRONT ROLLER WHEEL
19A	PPN23	FRONT ROLLER AXLE
20	PPN79	BUMPER
21	DM21	BOTTOM BASE SCREW
22	DM22	BRUSH ROLL RETAINER
23	DM23	SCREW-RETAINER
24	DM24	ATTACHMENT HOSE
25	DM25	DUCT HOSE COVER
26	PPN7	BRUSH ROLL COMPLETE
27	DM27	HANDLE ASSEMBLY COMPLETE
28	DM28	TOP BAG HOUSING COMPLETE WITH LID
28A	DM28A	ON/OFF SWITCH
29	LUXMH	LOWER MOTOR HOUSING
29A	DM29A	SUCTION END MOTOR HOUSING GASKET
29B	DM29B	SUCTION MOTOR
29C	DM29C	COMMUTATOR END GASKET
30	DM30	HEPA FILTER
31	DM31	WIRE HARNESS COMPLETE
32	DM32	BULKHEAD WITH ELECTRICAL RECEPTACLE
33	10-1032	100 PK UPRIGHT BAG
33A	10-1154	12 PK UPRIGHT BAG
34	DM34	PLASTIC WAND ASSEMBLY
35	DM35	50 FT - 18/3 EXTENSION CORD
36	DB4705	COMBO DUST BRUSH / UPHOLSTERY TOOL
37	DM37	CREVICE TOOL
38	DM38	CORD CONNECTOR ASSEMBLY