



Owner's Manual



This household sewing machine is designed to comply with IEC/EN 60335-2-28 and UL1594.

IMPORTANT SAFETY INSTRUCTIONS

When using an electrical appliance, basic safety precautions should always be followed, including the following:

Read all instructions before using this household sewing machine. Keep the instructions at a suitable place close to the machine. Make sure to hand them over if the machine is given to a third party.

DANGER – TO REDUCE THE RISK OF ELECTRIC SHOCK:

- A sewing machine should never be left unattended when plugged in. Always unplug this sewing machine from the electric outlet immediately after using and before cleaning, removing covers, lubricating or when making any other user servicing adjustments mentioned in the instruction manual.

WARNING – TO REDUCE THE RISK OF BURNS, FIRE, ELECTRIC SHOCK, OR INJURY TO PERSON:

- Do not allow to be used as a toy. Close attention is necessary when this sewing machine is used by or near children.
- Use this sewing machine only for its intended use as described in this manual. Use only attachments recommended by the manufacturer as contained in this manual.
- Never operate this sewing machine if it has a damaged cord or plug, if it is not working properly, if it has been dropped or damaged, or dropped into water. Return the sewing machine to the nearest authorized dealer or service center for examination, repair, electrical or mechanical adjustment.
- Never operate the sewing machine with any air openings blocked. Keep ventilation openings of the sewing machine and foot control free from the accumulation of lint, dust, and loose cloth.
- Keep fingers away from all moving parts. Special care is required around the sewing machine needle.
- Always use the proper needle plate. The wrong plate can cause the needle to break.

- Do not use bent needles.
- Do not pull or push fabric while stitching. It may deflect the needle causing it to break.
- Wear safety glasses.
- Switch the sewing machine off (“0”) when making any adjustment in the needle area, such as threading needle, changing needle, threading bobbin, or changing presser foot, etc.
- Never drop or insert any object into any opening.
- Do not use outdoors.
- Do not operate where aerosol (spray) products are being used or where oxygen is being administered.
- To disconnect, turn all controls to the off (“0”) position, then remove plug from outlet.
- Do not unplug by pulling on cord. To unplug, grasp the plug, not the cord.
- The foot control is used to operate the machine. Avoid placing other objects on the foot control.
- Do not use the machine if it is wet.
- If the LED lamp is damaged or broken, it must be replaced by the manufacturer or it's service agent or a similarly qualified person, in order to avoid a hazard.
- If the supply cord connected with the foot control is damaged, it must be replaced by the manufacturer or its service agent or a similarly qualified person, in order to avoid a hazard.
- This sewing machine is provided with double insulation. Use only identical replacement parts. See instructions for Servicing of Double-Insulated Appliances.

SAVE THESE INSTRUCTIONS

FOR EUROPE ONLY:

This appliance can be used by children aged from 8 years and above and persons with reduced physical, sensory or mental capabilities or lack of experience and knowledge if they have been given supervision or instruction concerning use of the appliance in a safe way and understand the hazards involved. Children shall not play with the appliance. Cleaning and user maintenance shall not be made by children without supervision.

The noise level under normal operating conditions is less than 75dB(A).

The machine must only be used with foot control of type "FC-1902 (110-120V), FC-2902A/FC-2902D (220-240V)" manufactured by ZHEJIANG FOUNDER MOTOR CORPORATION LTD (China).

FOR OUTSIDE EUROPE:

This sewing machine is not intended for use by persons (including children) with reduced physical, sensory or mental capabilities, or lack of experience and knowledge, unless they have been given supervision or instruction concerning use of the sewing machine by a person responsible for their safety. Children should be supervised to ensure that they do not play with the sewing machine.

The noise level under normal operating conditions is less than 75dB(A).

The machine must only be used with foot control of type "FC-1902 (110-120V), FC-2902A/FC-2902D (220-240V)" manufactured by ZHEJIANG FOUNDER MOTOR CORPORATION LTD (China).

SERVICING OF DOUBLE INSULATED PRODUCTS

In a double-insulated product, two systems of insulation are provided instead of grounding. No ground means is provided on a double-insulated product, nor should a means for grounding be added to the product. Servicing of a double-insulated product requires extreme care and knowledge of the system and should be done only by qualified service personnel. Replacement parts for a double-insulated product must be identical to those parts in the product. A double-insulated product is marked with the words 'DOUBLE INSULATION' or 'DOUBLE INSULATED'.

TABLE OF CONTENTS

INTRODUCTION.....	6	Stitch Length.....	21
Machine Overview	6	Stitch Width.....	22
Front Side.....	6	Adjustable Needle Position.....	22
Top Parts.....	7	Reverse Sewing.....	22
Rear Side.....	7		
Accessories.....	7	SEWING	23
Included Accessories not in Picture.....	7	Start to Sew - Straight Stitch.....	23
Presser Feet.....	8	Change Sewing Direction.....	23
Stitch Overview - 160s.....	9	Finish Sewing.....	23
Stitch Overview - 140s.....	10	Reinforced Straight Stitch.....	24
		Three-Step Zigzag Stitch.....	24
PREPARATIONS	11	Overlock Stitch.....	25
Unpacking	11	Closed Overlock Stitch.....	25
Connect to the Power Supply	11	Blindhem.....	26
Pack away after Sewing.....	12	Sewing on Patches or Appliqués.....	27
Free Arm	12	Darning with the	
Leveling the Machine Base Plate.....	12	Three-Step Zigzag Stitch.....	27
Thread Cutter.....	12	Repairing Tears.....	27
Spool Pins	13	Sewing on Buttons.....	28
Threading the Machine.....	14	Standard Buttonhole (model 160s).....	29
Needle Threader	15	Standard Buttonhole (model 140s).....	30
Threading for Twin Needle.....	16	Corded Buttonhole (Stretch Fabrics)	31
Bobbin Winding.....	17	Sewing Zippers	32
Inserting the Bobbin	17		
Presser Foot Pressure	18	MAINTENANCE	33
Thread Tension	18	Cleaning the Machine	33
Needles.....	19	Cleaning the Bobbin Area	33
Changing the Needle	19	Cleaning Under the Bobbin Area	33
Lowering Feed Dogs	20	Replacing the Stitch Plate	33
Presser Foot Lift.....	20		
Changing the Presser Foot	20	TROUBLESHOOTING	34
Stitch Selection	21		

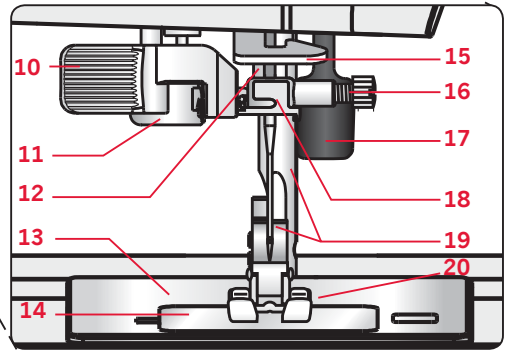
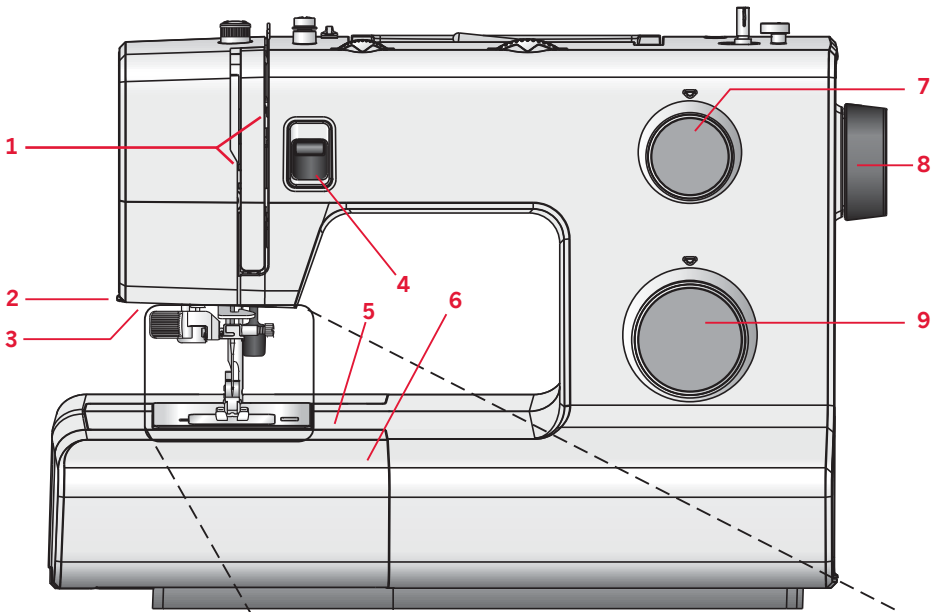

INTRODUCTION

Machine Overview

Front Side

- | | |
|---|--|
| <ul style="list-style-type: none"> 1. Threading slots 2. Thread cutter 3. LED light 4. Reverse lever 5. Free arm 6. Accessory tray 7. Stitch length dial 8. Handwheel 9. Stitch selection dial | <ul style="list-style-type: none"> 10. Built-in needle threader 11. Buttonhole lever (only 160s) 12. Needle bar 13. Stitch plate 14. Bobbin cover 15. Lower thread guide 16. Needle screw 17. Presser foot lift 18. Needle thread guide 19. Presser foot bar and presser foot holder 20. Presser foot |
|---|--|

Top Parts

21. Presser foot pressure dial
22. Thread guides
23. Spool caps/Spool pin
24. Hole for auxiliary spool pin
25. Bobbin winder spindle
26. Take-up lever
27. Thread tension discs
28. Bobbin winder tension disc
29. Thread tension dial
30. Stitch width dial

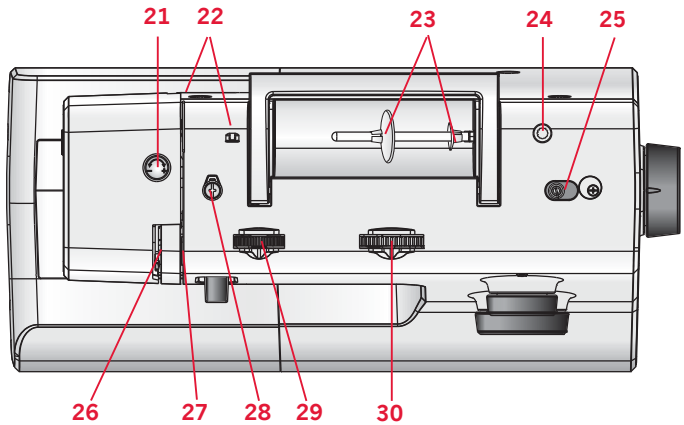

Rear Side

31. Main switch, connectors for power cord and foot control
32. Handle
33. Slide for lowering the feed dogs

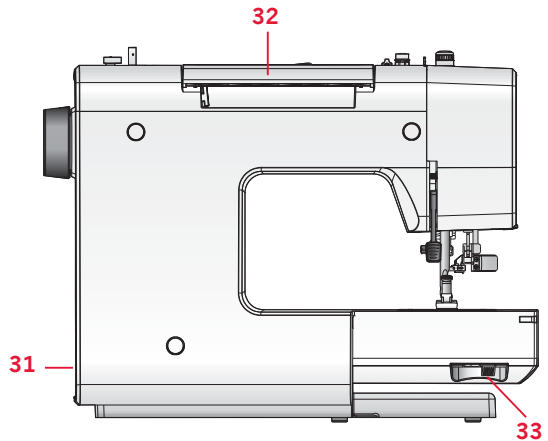

Accessories

34. Bobbins (3)
35. Felt pad
36. Screwdriver
37. Spool cap, large
38. Spool cap, small
39. Seam ripper & brush (as one)
40. Edge guide
41. Auxiliary spool pin

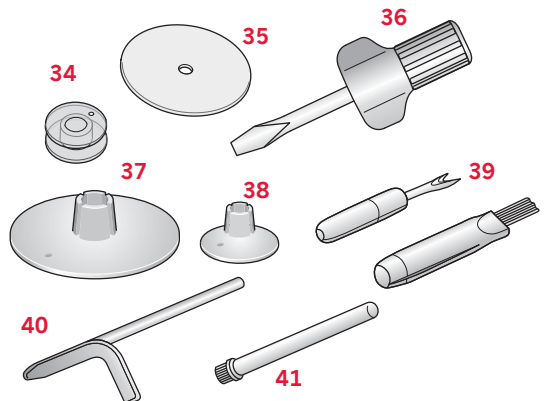

Included Accessories not in Picture

- Foot control and power cord
- Needles
- Hard cover

Presser Feet



Standard Presser Foot 0

This foot is used mainly for straight stitching and zigzag stitching with a stitch length longer than 1.0 mm.

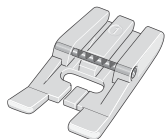

Clearview Foot 1

When sewing decorative stitches or short zigzag stitches and other utility stitches with less than 1.0mm stitch length, use this foot. The groove on the underside of the foot is designed to flow smoothly over the stitches.

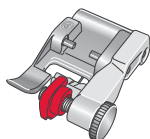

Blindhem Foot 3

This foot is used for blindhem stitches. The toe on the foot guides the fabric. The red guide on the foot is designed to ride along the fold of the hem edge.

Note: Always use at least 5mm stitch width when using Blind Hem Foot 3. If using a stitch width other than the recommended, swing the needle by turning the hand wheel to make sure the needle doesn't hit the metal pin in the foot.



Zipper Foot 4

This foot can be snapped on either the right or the left of the needle, making it easy to sew close to both sides of the zipper teeth. Move the needle position to the right or left to sew closer to zipper teeth.

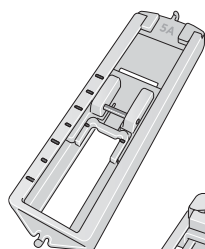

Four-Step Buttonhole Foot 5A (for 140s)



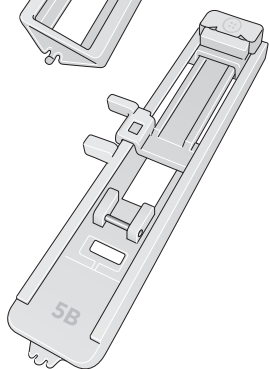





















Sliding plate under foot has conveniently spaced markings to start and stop your buttonhole at precisely the correct point.



One-Step Buttonhole Foot 5B (for 160s)





















This foot has a space in the back for a button used to set the size of the buttonhole. The machine will sew a buttonhole to fit that button size.

Stitch Overview – 160s

Stitch		Name	Description
	5B	1-step Buttonhole	Standard buttonhole
	0	Straight stitch	For all straight stitching and topstitching
	0	Zigzag stitch	For serging and appliqué
	0	Triple zigzag stitch	For stitching on elastic band, darning tears and patches
	3	Blindhem stitch	For invisible hem attachment
	3	Elastic blindhem stitch *	For invisible hem attachment and simultaneous serging, also for stretch fabrics
	1	Decor stitch	For all fabrics and types of work
	1	Checker satin stitch	Satin decorative stitch
	1	Open scallop	Satin decorative stitch
	1	Bridging Stitch *	For overcasting, sewing on elastic, darning tears and inserting patches
	0/1	Greek stitch	A traditional decorative stitch e.g. for borders and towels
	0/1	Shell-edging stitch	For decorative hems on fine materials, e.g. linen
	0	Reinforced straight stitch *	For stretch seams, e.g. crotch seams on sports- and workwear
	1	Reinforced zigzag stitch *	For attaching elastic tape on elastic materials
	1	Honeycomb stitch *	For sewing on elastic threads, overlocking towel-ling and for decorative hem seams
	1	Edge stitch narrow *	A decorative stitch
	3	Superstretch *	A decorative stretch stitch
	1	Decorative stitch	A decorative stitch
	1	Cross Stitches	A decorative stitch
	1	Decorative stitch	A decorative stitch
	0	Feather Stitch	A decorative stitch
	3	Closed overlock stitch *	A closing and serging seam for fraying materials
	3	Overlock stitch *	A closing and serging seam for stronger or non-fraying materials

* These stitches are stretch stitches

Stitch Overview – 140s

Stitch		Name	Description
	5A	4-step Buttonhole	Standard buttonhole
---	0	Straight stitch	For all straight stitching and topstitching
	0	Zigzag stitch	For serging and appliqué
	0	Triple zigzag stitch*	For stitching on elastic band, darning tears and patches
	3	Elastic blindhem stitch *	For invisible hem attachment and simultaneous serging, also for stretch fabrics
	3	Blindhem stitch	For invisible hem attachment
	0/1	Shell-edging stitch	For decorative hems on fine materials, e.g. linen
	0/1	Greek stitch	A traditional decorative stitch e.g. for borders and towels
	1	Bridging Stitch *	For overcasting, sewing on elastic, darning tears and inserting patches
	1	Checker satin stitch	Satin decorative stitch
	1	Open scallop	Satin decorative stitch
	0	Reinforced straight stitch *	For stretch seams, e.g. crotch seams on sports- and workwear
	1	Reinforced zigzag stitch *	For attaching elastic tape on elastic materials
	1	Honeycomb stitch *	For sewing on elastic threads, overlocking towel-ling and for decorative hem seams
	3	Superstretch *	A decorative stretch stitch
	1	Edge stitch narrow	A decorative stitch
	3	Overlock stitch *	A closing and serging seam for stronger or non-fraying materials
	3	Closed overlock stitch *	A closing and serging seam for fraying materials
	0	Feather Stitch	A decorative stitch
	1	Cross Stitches	A decorative stitch
	1	Decorative stitch	A decorative stitch

* These stitches are stretch stitches

PREPARATIONS

Unpacking

1. Place the box on a steady, flat surface. Lift the machine out of the box, remove the outer packaging and lift off the machine carrying case.
2. Remove all outer packing material and the plastic bag.

Note: Your SMARTER BY PFAFF™ 140s/160s sewing machine is adjusted to provide the best stitch result at normal room temperature. Extreme hot and cold temperatures can affect the sewn result.

Connect to the Power Supply

Among the accessories you will find the power plug and the foot control.

Note: Consult a qualified electrician if in doubt as how to connect the machine to the power source. Unplug the power cord when the machine is not in use.

For this sewing machine, foot control model FC-1902 (110-120V), FC-2902A/FC-2902D (220-240V) manufactured by ZHEJIANG FOUNDER MOTOR CORPORATION LTD (China) must be used.

1. Connect the plug of the foot control to the connecting socket (A) of the sewing machine and to the wall socket. The sewing speed is regulated by pressing the foot control.
2. Press the O/I switch (B) to "I" to turn on power and light.

For the USA and Canada

This sewing machine has a polarized plug (one blade wider than the other). To reduce the risk of electric shock, this plug is intended to fit in a polarized outlet only one way. If the plug does not fit fully in the outlet, reverse the plug. If it still does not fit, contact a qualified electrician to install the proper outlet. Do not modify the plug in any way.

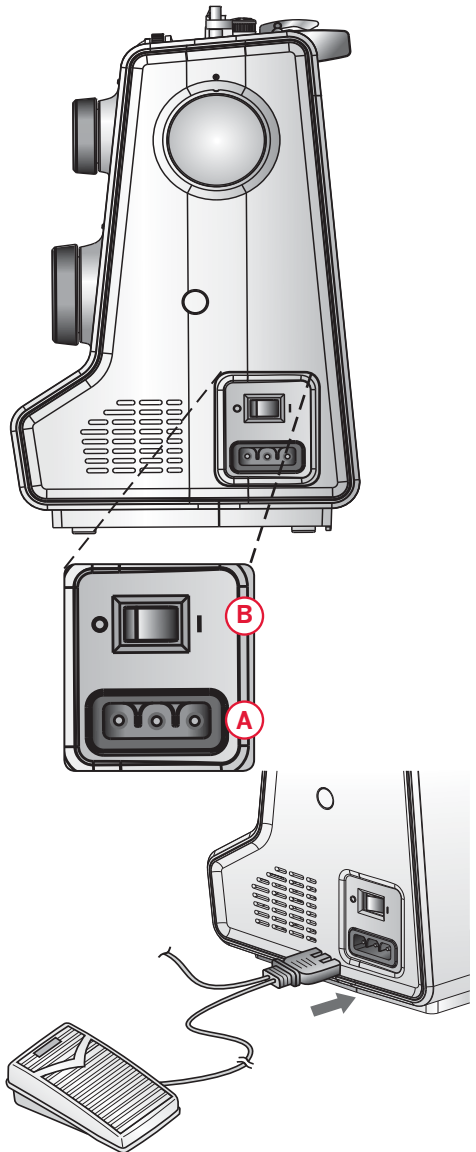

Pack away after Sewing

1. Switch the main switch off.

Note: After switching off, residual power may still remain in the machine. This may cause the light to stay on for a few seconds while the power is consumed. This is normal behavior for an energy efficient appliance.

2. Unplug the cord from the wall socket and then from the machine.
3. Unplug the foot control cord from the machine. Wind the cord around the foot control for easy storage.
4. Place all accessories in the accessory tray. Slide the tray on to the machine around the free arm.
5. Place the foot control in the space above the free arm.
6. Put on the hard cover.

Free Arm

To use the free arm, slide off the accessory tray. When attached, a hook keeps the accessory tray securely attached to the machine. Remove the tray by sliding it to the left.

Leveling the Machine Base Plate

To make sure your machine stands steadily on your sewing surface you can adjust the base plate height.

Turn the base plate adjusting screw (A) by hand. Turn clockwise to lower and counter-clockwise to raise the base plate.

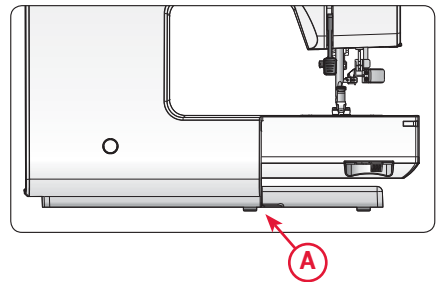

Thread Cutter

To use the thread cutter, pull the thread from back to front as shown (B).

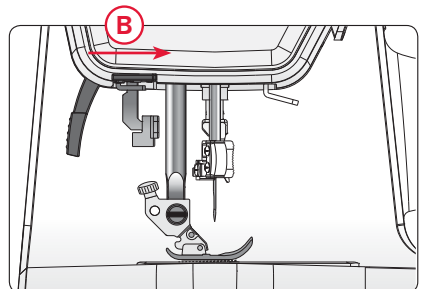

Spool Pins

Your machine has two spool pins, a main spool pin and an auxiliary spool pin. The spool pins are designed for all types of thread. The main spool pin is used in a horizontal position (the thread reels off the spool) and the auxiliary spool pin in a vertical position (the thread spool rotates). Use the horizontal position for normal threads and the vertical position for large spools or specialty threads.

Main Spool Pin

Place a spool cap and the thread spool on the spool pin. Make sure that the thread reels off the spool counter clock-wise and slide on a second spool cap.

Note: Not all thread spools are manufactured in the same way. If you experience problems with the thread, turn it in the opposite way or use the vertical position.

Use a spool cap slightly larger than the thread spool. For narrow thread spools, use a smaller spool cap in front of the spool. For large thread spools, use a larger spool cap in front of the spool.

The flat side of the spool cap should be pressed firmly against the spool. There should be no space between the spool cap and the thread spool.

Auxiliary Spool Pin

The auxiliary spool pin is used when winding a bobbin thread from a second spool of thread or for a second spool when sewing with a twin needle.

Insert the auxiliary spool pin into the hole at the top of the machine (A). Slide on a large spool cap and place a felt pad under the thread spool. This is to prevent the thread from reeling off too fast.

Do not place a spool cap on top of the spool as that would prevent the spool from rotating.

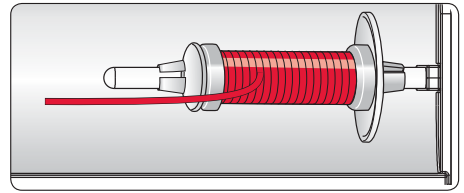

Narrow thread spool

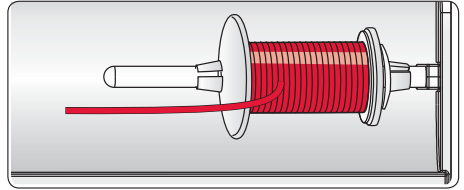

Large thread spool

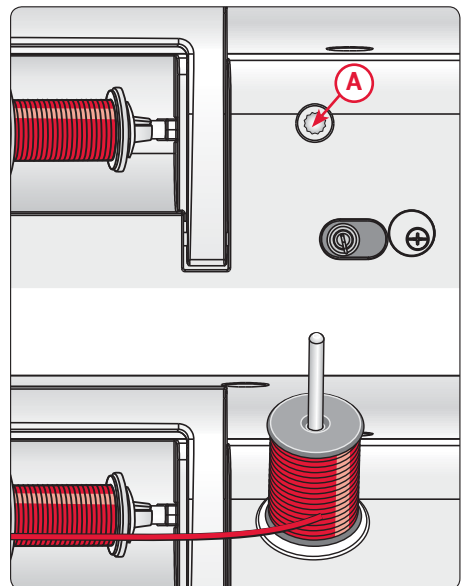

Auxiliary spool pin

Threading the Machine

Make sure that the presser foot is raised and the needle is in its highest position.

1. Place the thread on the spool pin and fit the appropriately sized spool cap.
2. Pull the thread into the thread guide (A) from front to the back. Pull the thread between the tension discs (B).
3. Thread down through the right threading slot (C) and then upwards through the left threading slot (D).
4. Bring the thread from the right into the take-up lever (E) and down in the left-hand threading slot, into the lower thread guide (F) and to the needle thread guide (G).
5. Thread the needle.

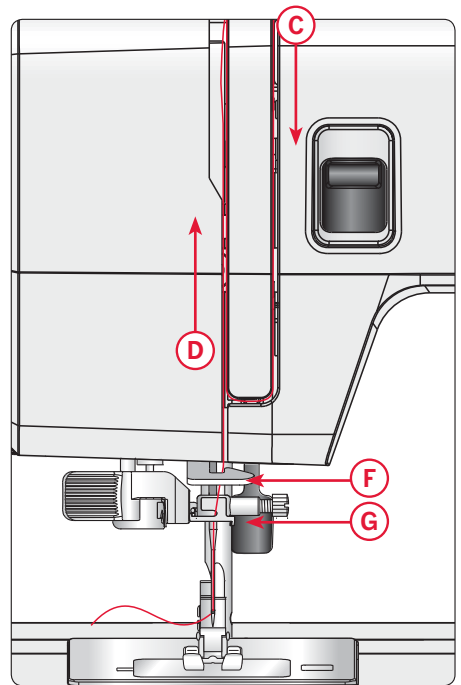
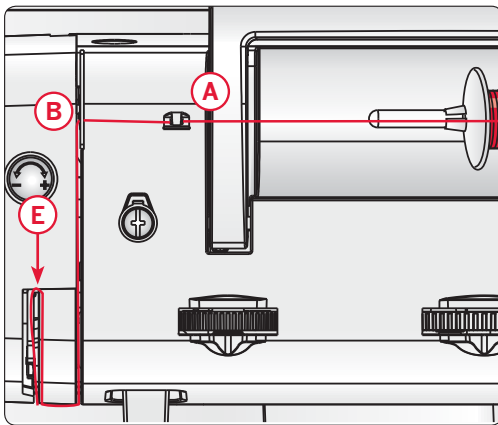

Needle Threader

The integrated needle threader allows you to thread the needle quick and easy.

The needle must be in its highest position to use the built-in needle threader. Turn the handwheel until the notch on the wheel is pointing upwards (A). We also recommend lowering the presser foot.

1. Use the handle (B) to pull the needle threader all the way down. The metal flanges cover the needle. A small hook will pass through the needle eye.
2. Place the thread from the back over the thread guide (C) and under the small hook (D).
3. Let the needle threader gently swing back. The hook pulls the thread through the needle eye and forms a loop behind the needle. Pull the thread loop out behind the needle.
4. Raise the presser foot and place the thread under it.

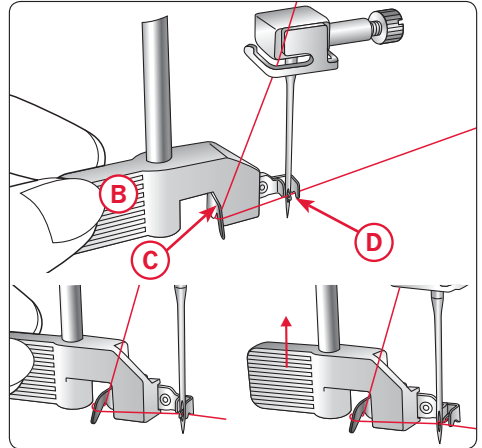
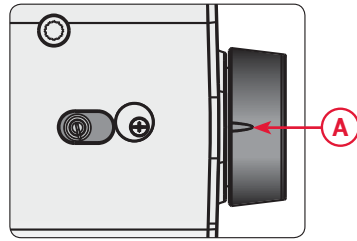

Note: The needle threader is designed to be used for size 70-120 needles. You cannot use the needle threader for size 60 needles or smaller, wing needles or twin needles.

There are also some optional accessories that require manual threading of the needle.

When threading the needle manually, make sure that the needle is threaded from front to back.

Threading for Twin Needle

Replace the sewing needle with a twin needle. Make sure that the presser foot is raised and the needle is in its highest position.

1. Place the thread spool on the spool pin and fit the appropriately sized spool cap. Insert the auxiliary spool pin. Slide on a large spool cap and a felt pad. Place the second thread spool on the spool pin.
2. Pull the threads into the thread guide (A) from front to the back. Pull both threads between the tension discs (B).
3. Thread down through the right threading slot (C) and then upwards through the left threading slot (D).
4. Bring the threads from the right into the take-up lever (E) and down into the left threading slot. Place the threads into the lower thread guide (F). Place one thread into the slot on the left side of the needle thread guide (G) and the other thread into the slot on the right side of the needle thread guide (H). Make sure that the threads do not become twisted.
5. Thread the needles manually from front to back.

Note: When you are using a twin needle, you might need to reduce the stitch width to prevent damage of the twin needle, stitch plate or presser foot. How much you need to reduce it depends on the width and/or the size of the twin needle.

Note: The weight and irregular surface of specialty threads such as metallic increases the amount of friction on the thread. By reducing the tension, the risk of needle breakage is prevented.

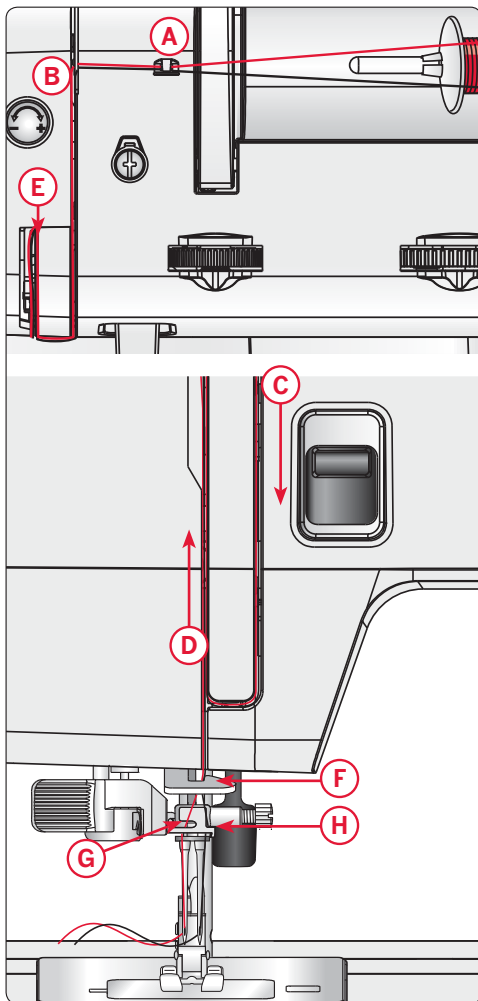

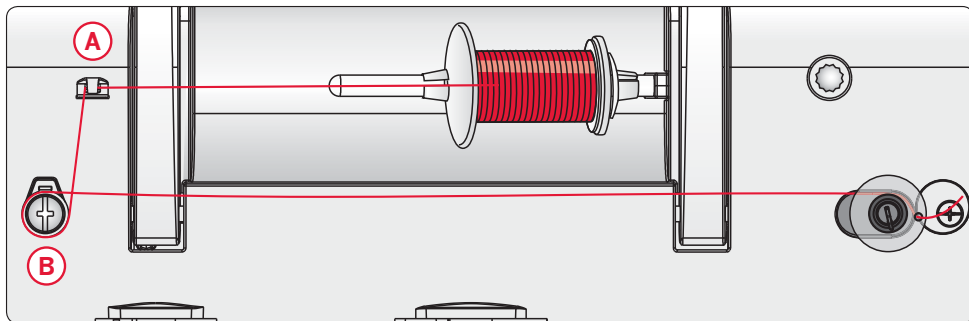

Bobbin Winding

1. Place the thread spool on the spool pin. Slide a spool cap tightly against the spool.
2. Place the thread into the thread guide (A) from front to the back. Pull the thread clockwise around the bobbin winder tension disc (B).
3. Thread through the hole in the bobbin (C) from the inside to the outside.
4. Place the bobbin on the bobbin spindle.
5. Push the bobbin spindle to the right to activate the bobbin winding. Press the foot control to wind the bobbin. Once the bobbin begins to wind, cut the excess thread. When the bobbin is full, the bobbin winding will slow down and stop automatically. Push the bobbin spindle to the left. Remove the bobbin and cut the thread.

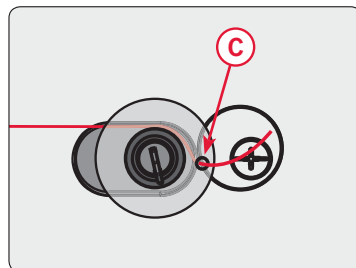

Inserting the Bobbin

Make sure that the needle is fully raised and the machine is turned off before inserting or removing the bobbin.

1. Open the bobbin cover by pushing the release button to the right (A). Remove the cover (B).
2. Insert the bobbin in the bobbin case with the thread running in a counterclockwise direction.
3. Pull the thread through the slit (C).
4. Pull the thread clockwise until it slips into the notch (D).
5. Replace the bobbin cover.

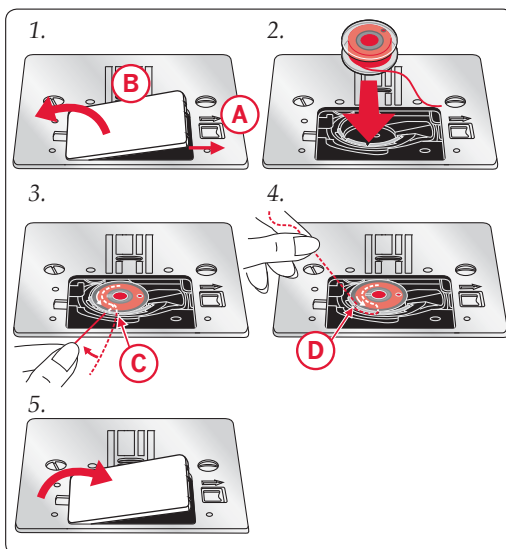

Presser Foot Pressure

The presser foot pressure has been pre-set to the standard value “2”. In most cases, you do not need to adjust the presser foot pressure. For specialty techniques or when sewing on very light or heavy fabric, adjusting the pressure can improve the result.

For very light fabrics, loosen the pressure by turning the dial counterclockwise.

Note: If the dial is turned counterclockwise too much, it could come off. If this happens, simply replace the dial and turn it clockwise until it stays in place.

For heavy fabric, tighten the pressure by turning the dial clockwise.

Note: If the dial is turned clockwise until it comes to a stop, it has reached the maximum pressure available. Do not try to turn the dial any further!

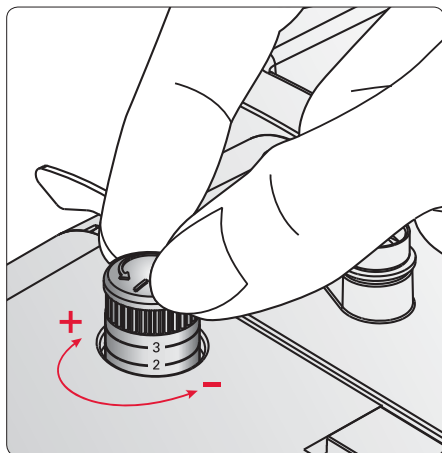

Thread Tension

To set the thread tension, turn the dial on top of the machine. Depending on the fabric, batting, thread, etc., the tension may need to be adjusted.

For the best stitch appearance and durability, make sure the needle thread tension is correctly adjusted. For general sewing, the threads evenly meet between the two layers of fabric (A).

If the bobbin thread is visible on the top side of the fabric, the needle thread tension is too tight (B). Reduce the needle thread tension.

If top thread is visible on the underside of the fabric, the needle thread tension is too loose (C). Increase the needle thread tension.

For decorative stitches and buttonholes, the top thread should be visible on the underside of the fabric.

Make a few tests on a scrap piece of the fabric you are going to sew and check the tension.

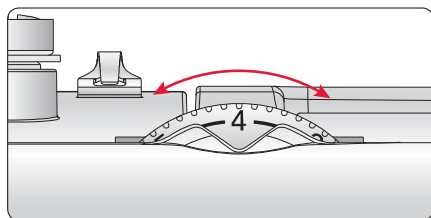

Correct tension



Tension too tight



Tension too loose

Needles

The sewing machine needle plays an important role in successful sewing. Use only quality needles. We recommend needles of system 130/705H. The needle package included with your machine contains needles of the most frequently used sizes.

Universal Needle (A)

Universal needles have a slightly rounded point and come in a variety of sizes. For general sewing in a variety of fabric types and weights.

Stretch Needle (B)

Stretch needles have a special scarf to eliminate skipped stitches when there is a flex in the fabric. For knits, swimwear, fleece, synthetic suedes and leathers. Marked with a yellow band.

Denim Needle (C)

Denim needles have a sharp point to penetrate tightly woven fabrics without deflecting the needle. For canvas, denim, microfibers. Marked with a blue band.

Note: Change the needle often. Always use a straight needle with a sharp point (D).

A damaged needle (E) can cause skipped stitches, breakage or snapping of the thread. A damaged needle can also damage the stitch plate.

Do not use asymmetrical twin needles (F), since they may damage your sewing machine.

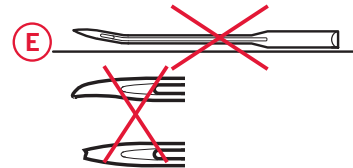
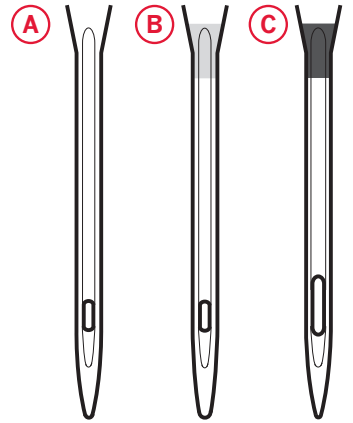

Changing the Needle

1. Loosen the needle screw. Use the screw-driver if necessary.
2. Remove the needle.
3. Push the new needle upwards with the flat side away from you until it will go no further.
4. Tighten the needle screw as tight as it will go.

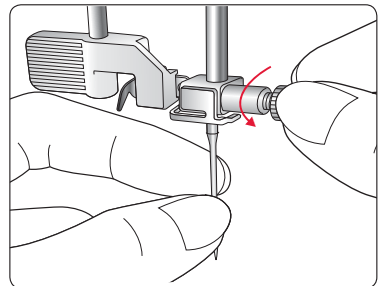

Lowering Feed Dogs

You can lower the feed dogs by moving the switch at the back of the free arm to the left (A). Move the switch to the right if you wish to raise the feed dogs.

Note: The feed dogs will not raise immediately when the lever is switched. Turn the handwheel one full turn or start sewing to re-engage the feed dogs.

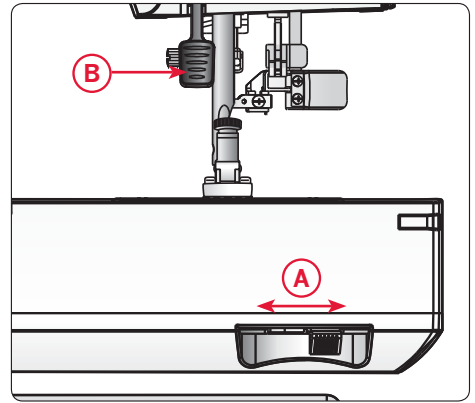

Presser Foot Lift

The presser foot is lowered or raised with the presser foot lift (B). By raising the presser foot lever as far as it goes the lift height of the presser foot can be increased. This is useful for easy removal of the presser foot or when placing heavy fabrics under the foot.

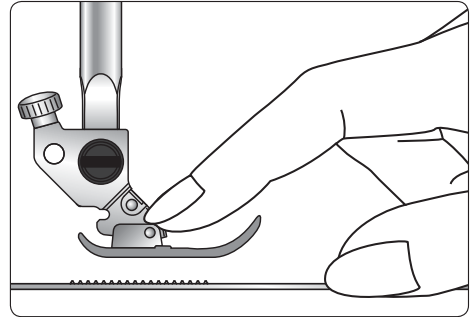

Changing the Presser Foot

Remove Presser Foot

Press the presser foot downwards until it snaps off from the presser foot holder.

Attach Presser Foot

Place the presser foot under the presser foot holder (A). Line up the cross pin on the foot (B) with the gap in the presser foot ankle (C).

Lower the presser foot lifter and the presser foot will snap into the presser foot holder.

Note: Check that the presser foot is properly attached by raising the presser foot lift.

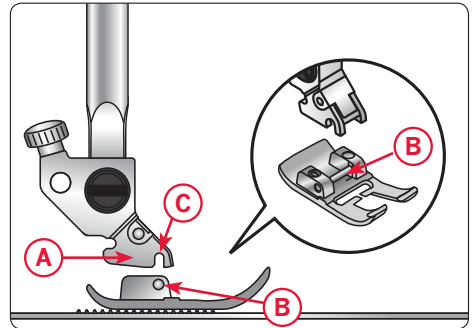

Stitch Selection

Raise the needle to its highest position (A).

Turn the stitch selection dial (B) to set the desired stitch. The selected stitch is the one underneath the setting mark (C).

The stitches printed in white on the stitch selection dial have a fixed stitch length (see below).

Use non-stretch stitches when sewing woven fabrics, leather or vinyl and stretch stitches when using stretch fabrics (see Stitch Overview to find out which stitches are stretch stitches).

Note: Always raise the needle above the fabric and presser foot before you turn the stitch selection dial.

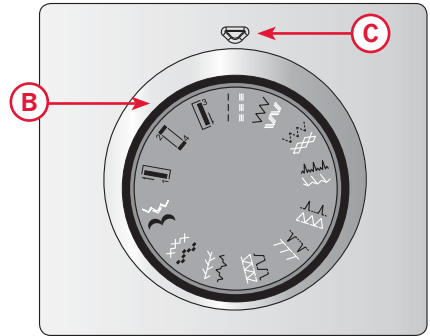
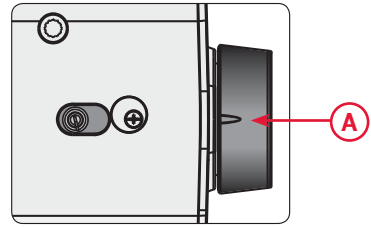

Stitch Length

Turn the stitch length dial (A) until the desired stitch length corresponds to the setting mark (B). The higher the number, the longer the stitch. The stitch length can be varied from 0-4mm (the numbers on the selection wheel correspond to the stitch length in mm).

When sewing using the stitches printed in white on the Stitch Selection wheel, set the stitch length dial to "S1".

The  mark shows the adjustment range when sewing the buttonhole.

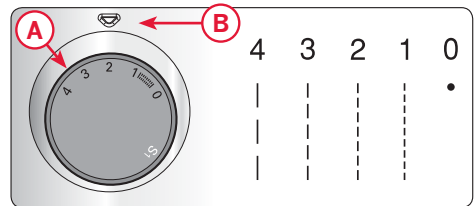

Stitch Width

Turn the stitch width dial (A) to set the desired stitch width.

The higher the number, the wider the stitch. A center straight stitch is set to "0" stitch width. The stitch width can be varied from 0-6mm (the numbers on the selection wheel correspond to the stitch width in mm).

Note: Before you turn the stitch width dial, raise the needle to its highest position, otherwise it may bend or break.

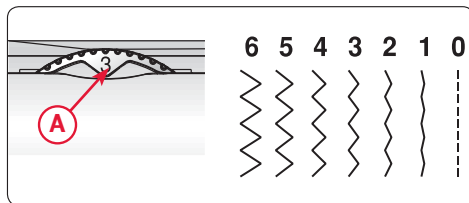

Adjustable Needle Position

When a straight stitch is selected, the stitch width dial can be used to adjust the needle position from 0-6 mm. This is convenient when you need to adjust the position of the stitch for example when topstitching.

Note: Before you turn the stitch width dial, raise the needle to its highest position, otherwise it may bend or break.

On model 160s the needle position is adjusted from the center to the left. On model 140s the needle position is adjusted from the center to the right.

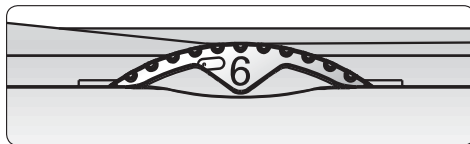

Model 160s

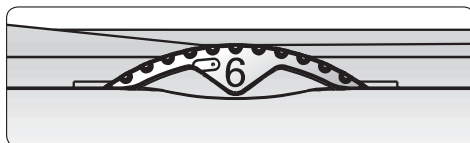

Model 140s

Reverse Sewing

Press the reverse lever down to sew in reverse.

The machine sews in reverse only as long as the reverse sewing button is pressed.

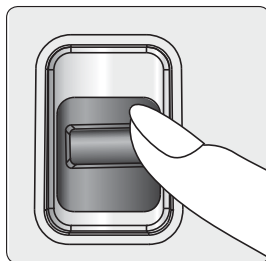

SEWING

Next to each stitch or sewing technique described, a chart shows the recommended settings and presser foot. See explanations of the chart to the right.

stitch	----	~~~~~	XXX	
	2-4	0	3-5	0

Start to Sew – Straight Stitch

Set your machine for straight stitch (see chart to the right).

Raise the presser foot and position the fabric under it, next to a seam allowance guide line on the needle plate. On the bobbin cover there is a 1/4" (6mm) guide line.

Lower the needle to the point where you want to start. Lower the presser foot and pull the threads toward the back. Press the foot control. Gently guide the fabric along the seam guide letting the machine feed the fabric.

Note: Some sewing is done more easily by changing the needle position, e.g. topstitching a collar or sewing in a zipper. The needle position is determined by the stitch width dial (0 is center, 6 is left/right, see page 22).

Change Sewing Direction

To change sewing direction, stop the machine and turn the handwheel toward you to bring the needle down into the fabric.

Raise the presser foot.

Pivot the fabric around the needle to change sewing direction as desired. Lower the presser foot and continue sewing in the new direction.

Finish Sewing

Press the reverse stitch lever and sew several stitches in reverse at the end of the seam.

Raise the presser foot and remove the fabric, pulling the threads to the back.

Pull the threads up and into the thread cutter.

The threads are cut the proper length for starting the next seam.



A. Recommended stitch

B. Stitch length in mm

C. Stitch width in mm

D. Thread tension

E. Recommended presser foot

stitch	----	~~~~~	XXX	
	2-4	0	3-5	0

Set for Straight Stitch

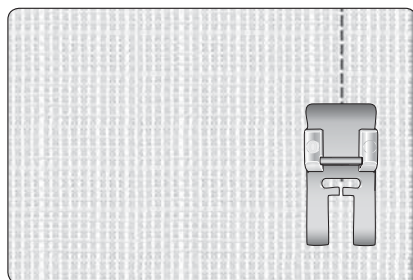
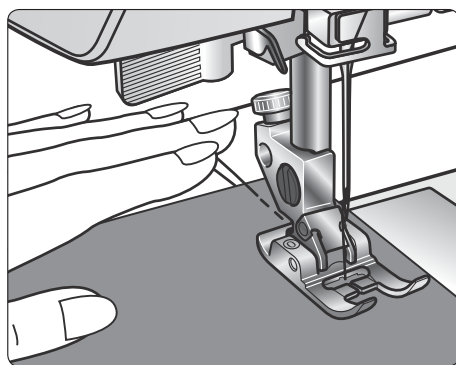

Reinforced Straight Stitch

This stitch is stronger than regular straight stitch, due to the fact that it is a triple and elastic stitch. The reinforced straight stitch can be used for heavy stretch fabrics, for crotch seams which are subject to considerable strain and for topstitching heavy fabrics.

The stitch is sewn with two stitches forward and one stitch backward, forming a seam that does not rip easily.

Carefully guide the fabric while sewing as the fabric moves back and forth.

stitch	-----	~~~~~	XXX	
	S1	0	2-5	0

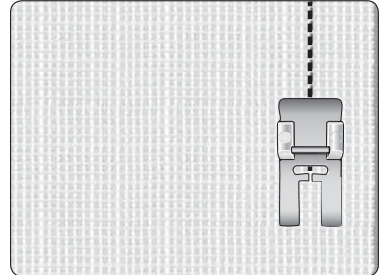

Set for reinforced straight stitch



Three-Step Zigzag Stitch

Three-step zigzag stitch is used to overcast raw edges. Make sure the needle pierces the fabric on the left side and overcasts the edge on the right side.

The stitch can also be used as an elastic stitch to allow seams to stretch when sewing knit fabrics.

stitch	-----	~~~~~	XXX	
	1	3-5	3-6	0

Set for three-step zigzag stitch

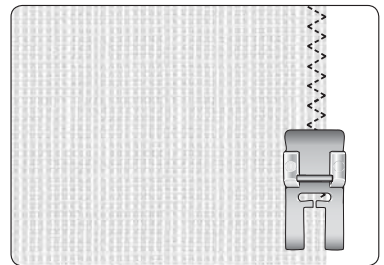



Overlock Stitch

The open overlock stitch sews the seam and overcast the edge all at one time, perfect for stretch fabrics. This stitch is more elastic than normal seams, very durable and quickly sewn.

Tip: When sewing, guide the fabric edge along the metal pin of the foot. By doing so, the stitches form over the pin and prevent the fabric from puckering.

Note: If using a stitch width other than the recommended, swing the needle by turning the hand wheel to make sure the needle doesn't hit the metal pin in the foot.

stitch	-----	~~~~~	XXX	
	S1	5	3-7	3

Set for overlock stitch

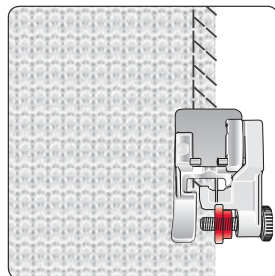

Closed Overlock Stitch

The closed overlock stitch is perfect for sewing jersey knits. Durable stitch; great for attaching knit collars and cuffs.

Tip: When sewing, guide the fabric edge along the metal pin of the foot. By doing so, the stitches form over the pin and prevent the fabric from puckering.

Note: If using a stitch width other than the recommended, swing the needle by turning the hand wheel to make sure the needle doesn't hit the metal pin in the foot.

stitch	-----	~~~~~	XXX	
	S1	5	3-7	3

Set for closed overlock stitch

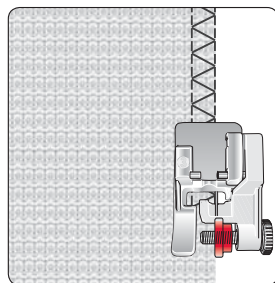

Use this stitch to hem stretch fabrics (A) and for belt loops (B). Fold a hem to the wrong side and stitch with closed overlock stitch from the right side. Trim away excess fabric. Use this technique to make belt loops, too (see illustration to the right).

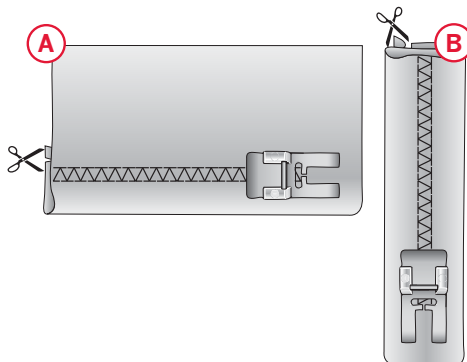

Blindhem

The blindhem stitch is used to make invisible hems on skirts, trousers and home decorating.

1. Finish the edge of the hem.
2. Fold and press the hem allowance to the wrong side.
3. Fold the hem back on itself so approximately 3/8" (1 cm) of the finished edge extends beyond the fold. The wrong side of your project should now be facing up.
4. Place the fabric under the presser foot so that the fold runs along edge guide (A).
5. When the needle swings into the fold it should catch a small amount of fabric. If the stitches are visible on the right side, adjust the edge guide (A) by turning adjusting screw (B) until the stitch that catches the hem just barely shows.

Elastic Blindhem Stitch

The elastic blindhem stitch is especially suitable for stretchy fabrics, because the zigzag in the stitch lets the stitch stretch. The hem is finished and sewn at the same time. There is no need to finish the raw edge first on most knits.

Note: If using a stitch width other than the recommended, swing the needle by turning the hand wheel to make sure the needle doesn't hit the metal pin in the foot.

stitch	-----	~~~~~	XXXX	
 or 	1-2	5	3-5	3

Set for blindhem stitch

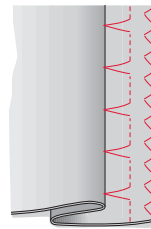
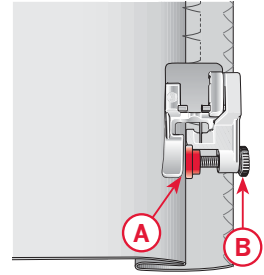

Blindhem stitch

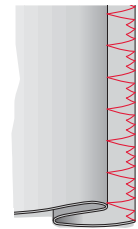

Elastic Blindhem stitch

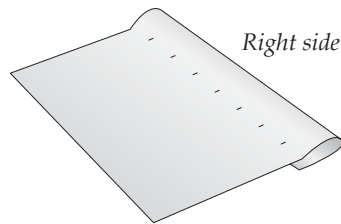

Right side of fabric

Sewing on Patches or Appliqués

To cover large holes it is necessary to sew a new piece of fabric onto the damaged area.

Baste the new piece of fabric onto the damaged area on the right side of the fabric.

Sew over the fabric edges with the zig zag or the three-step zigzag stitch.

Trim the damaged area close to the seam from the wrong side of the fabric.

Zigzag, three-step zigzag, the closed overlock stitch or the honeycomb stitch can be used to make appliqués.

Pin or baste a patch to your fabric/project and stitch around the edges with any of the stitches.

Darning with the Three-Step Zigzag Stitch

A small hole or tear is easily darned with the three-step zigzag stitch.

Sew over the damaged area in rows until it is well covered. Make sure that the rows overlap.

Tip: To make the darning even sturdier, place a fabric underneath the hole/tear before sewing.

Repairing Tears

On tears, frayed edges or small holes it is useful to lay a piece of fabric on the wrong side of the fabric. The underlaid fabric reinforces the damaged area.



Lay a piece of fabric underneath the damaged fabric. It must be a little larger than the damaged area.

Sew over the damaged area using the zigzag or three-step zigzag stitch.

Trim the piece of fabric used as reinforcement.

stitch	-----	~ ~ ~ ~ ~	XXX	
	1-2	5	3-5	0

Set for three-step zigzag

stitch	-----	~ ~ ~ ~ ~	XXX	
	2	4-6	3-5	0

Set for zigzag stitch

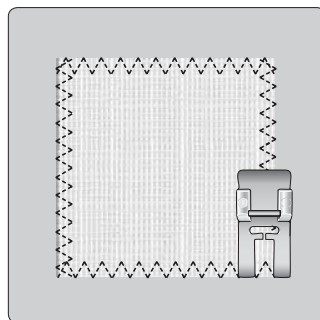

Sew patches or appliqués

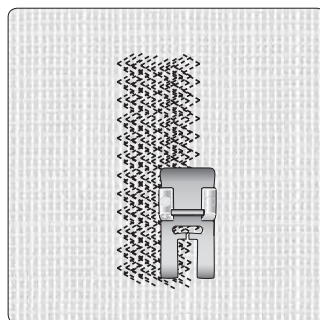

Darning with three-step zigzag

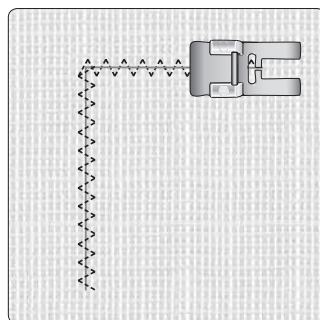

Repairing tears

Sewing on Buttons



Sew buttons quickly with your sewing machine.

1. Remove the presser foot and lower the feed dogs (A).
2. Mark the fabric where the button is to be located. Place the fabric and button under the ankle with the holes in the button lined up with the swing of the needle. Bring the needle down into the holes of the button with the hand wheel to verify that the correct stitch width is set.

Note: The recommended width of 3mm is set for most buttons. If you sew a tiny button or a very large coat button, decrease or increase the stitch width until the swing of the needle sews in the holes of the button.

Note: Do not use this technique if the button is less than 1 cm (3/8") in diameter.

3. Press the foot control and sew six to eight stitches. Set the stitch width dial to 0 and fix the threads with a few stitches.
4. Raise feed dogs when button sewing is completed.

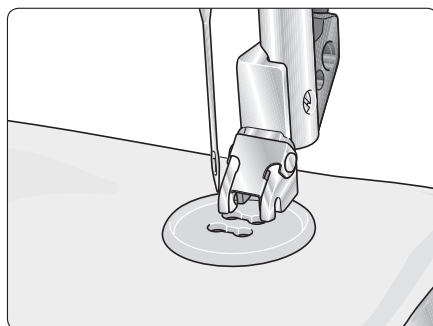
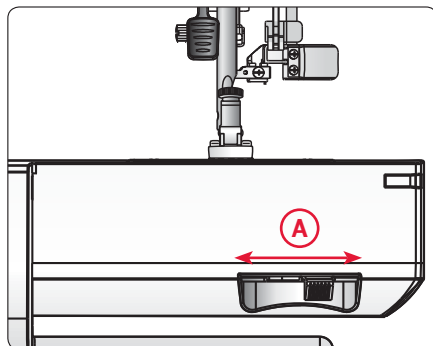

stitch	-----	~~~~~	XXXX	
	0	3-5	3-5	-

Set for button sewing



Standard Buttonhole (model 160s)

The fabric should be interfaced and/or stabilized where buttonholes are to be sewn.

stitch	-----	~~~~~	∞∞∞	
		4-6	3-5	5B

Set for buttonhole

1. Mark the start position and buttonhole length on the fabric (A).
2. Attach the One-Step Buttonhole Foot 5B. Push the button holder open by pushing the lever backwards (B). Insert the button. Push the button holder forward until the button is locked in place (C). The button will determine the length of the buttonhole.
3. Make sure that the thread is pulled though the hole in the presser foot and placed under the foot.
4. Position your garment under the presser foot so that the marking on the fabric is aligned with the center of the buttonhole foot (D).
5. Lower the buttonhole lever (E) all the way down, and push it away from you. The buttonhole lever should fit between the button holder lever (B) and the stopper (F).
6. Hold the end of the upper thread and start sewing. The buttonhole is sewn from the front of the presser foot to the back as illustrated to the right (G). Stop sewing when the last buttonhole column is finished.
7. Once the the buttonhole is finished, raise the presser foot. Pull the buttonhole lever towards you and push it all the way up.
8. To secure the bartack, thread the end of the top thread into a needle, pull to the wrong side and tie the end before cutting excess thread.

If you want to repeat the buttonhole, do not push the buttonhole lever up when the buttonhole is finished. Instead, sew another buttonhole.

Note: Always sew a test buttonhole on a piece of scrap fabric.

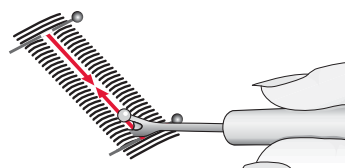
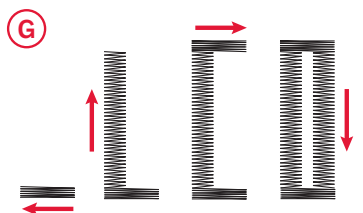
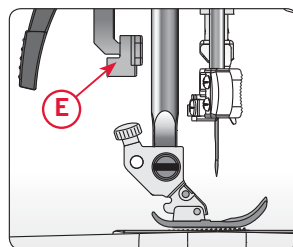
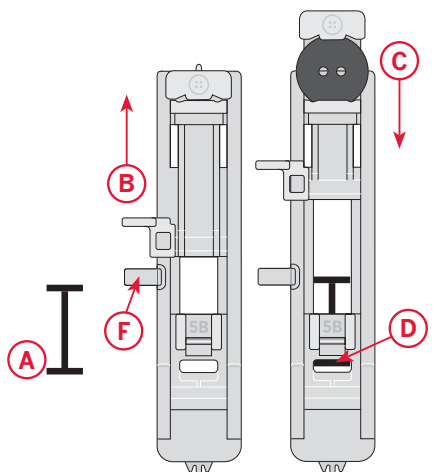

Carefully cut your buttonhole open with a seam ripper

Standard Buttonhole (model 140s)

The fabric should be interfaced and/or stabilized where buttonholes are to be sewn.





Prepare the Buttonhole

Measure diameter and thickness of the button and add 3mm (1/8") for bartacks to obtain correct buttonhole length. Mark the start position and buttonhole length on the fabric (A).

Attach the Four-Step Buttonhole Foot 5A. Slide the foot backwards as far as it will go.

Note: Before starting to sew any buttonhole, always push the the buttonhole foot fully back. The red marks are arranged at an interval of 0.5 cm. They are a guide when determining the length of the buttonhole.



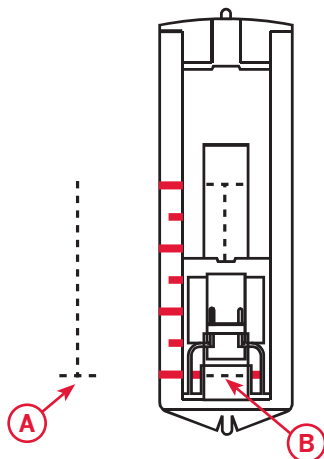

Place the fabric under the foot, so that the marking on the buttonhole foot (B) aligns with start position (A) on fabric. Lower the foot, so that the buttonhole center line marked on the fabric aligns with the center of the buttonhole foot (B).

stitch	-----	~~~~~	XXXX	
  		6	3-5	5A

Set for buttonhole



Sew the Buttonhole

1. Select stitch  and sew the right side of the buttonhole to the required length. Cut the top thread after a few stitches.
2. Raise the needle to its highest position. Select stitch  and sew a few bartacks.
3. Raise the needle to its highest position. Select stitch  and sew the left side of the buttonhole until it matches the previous side in length.
4. Raise the needle to its highest position. Select stitch  and sew a few bartacks.
5. To secure the buttonhole, thread the top thread into a needle, pull to the wrong side and tie the end before cutting excess thread.

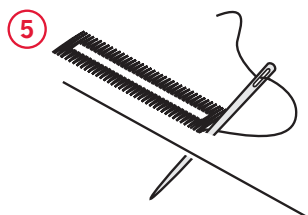
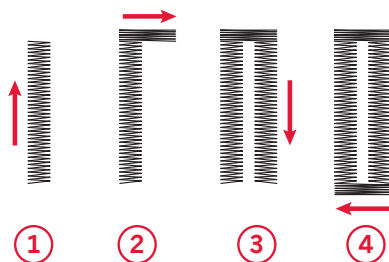

Use seam ripper and cut the buttonhole open from both ends towards the middle.

The density of the buttonhole is adjusted with the Stitch Length Dial in the “” area. Set the stitch width to “6”.

Note: Density varies according to the fabric. Always test sew a buttonhole on the fabric you are using to sew the buttonhole.

Tips:

- Slightly reducing upper thread tension will produce better results.
- Use an extra stabilizer for fine or stretchy fabrics.

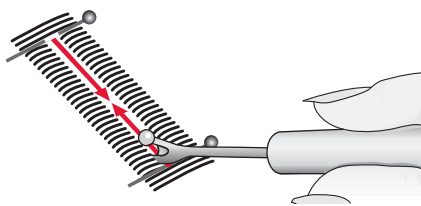

Carefully cut your buttonhole open with a seam ripper.

Corded Buttonhole (Stretch Fabrics)

When sewing buttonholes in stretch fabrics we recommend cording the buttonhole to increase the stability and to keep the buttonhole from stretching out.

1. Loop a piece of heavy thread or pearl cotton over the finger at the back of the foot (A). Pull the thread tails under the foot, toward the front, then secure around the finger at the front of the foot (B).
2. Stitch a buttonhole. The satin buttonhole columns will stitch over the cord.
3. When the buttonhole is finished, lift the cord off the fingers and pull out the slack.
4. Thread the cord ends into a needle, pull to the wrong side and tie ends before cutting excess.

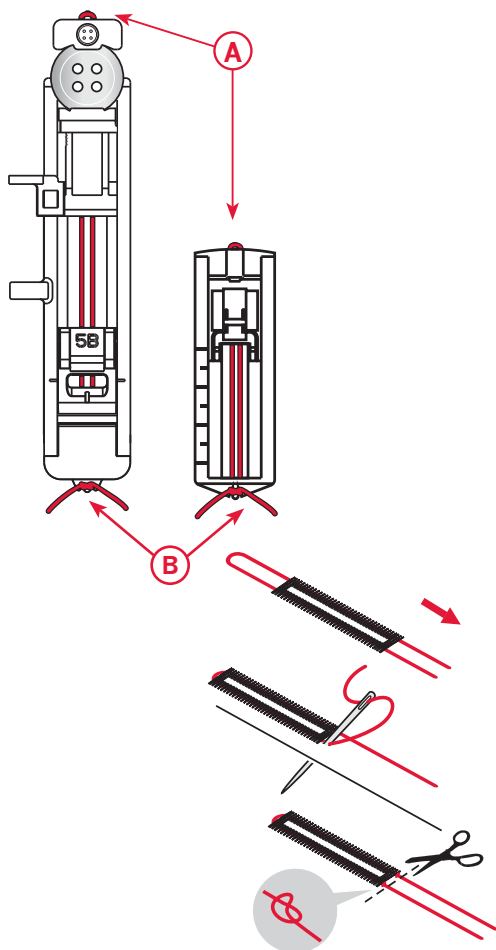

Sewing Zippers

The Zipper Foot 4 can be attached on either the right or the left of the needle, making it easy to sew both sides of the zipper.

To sew the left side of the zipper, attach the foot in the right presser foot position (A).

To sew the right side of zipper, attach the foot in the left presser foot position (B).

stitch	-----	~~~~~	XXXX	
	1.5-3	0	3-5	4

Set for zipper

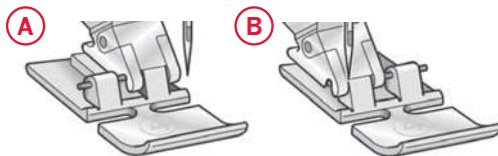

Right presser foot position

Left presser foot position

Center Zipper

1. Sew the two fabrics right sides together along the 5/8" (15mm) guide line (on the needle plate), stopping at the notch for the zipper placement.
2. Baste the remaining seam where the zipper will be placed (use straight stitch with stitch length 4mm, thread tension 2). Press the seam open. Place the zipper right side to the pressed open seam allowance, placing the zipper stop at the notch. Pin the zipper on the right side so it stays in place (C).
3. Set the machine for straight stitch (see table above). Attach Zipper Foot 4 so the needle is on the left side of the foot. Place fabric under the foot right side up with the zipper foot on the right side of the zipper.
4. Begin stitching across the bottom, turn the fabric and stitch the right side of the zipper to the top (see D).
5. To avoid fabric shifting, sew the left side of the zipper in the same direction. Attach the Zipper Foot 4 so the needle is on the right side of the foot. Move the needle position to the right.
6. Begin stitching across the bottom, turn the fabric and stitch the left side of the zipper sewing from the bottom to the top (see E).
7. Remove the basting stitches.

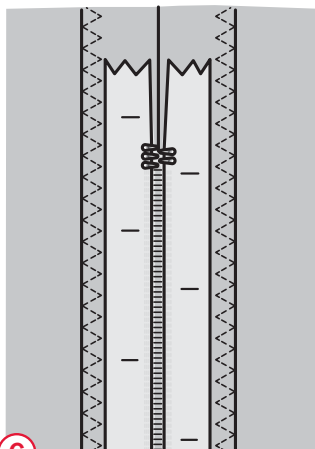

(C)

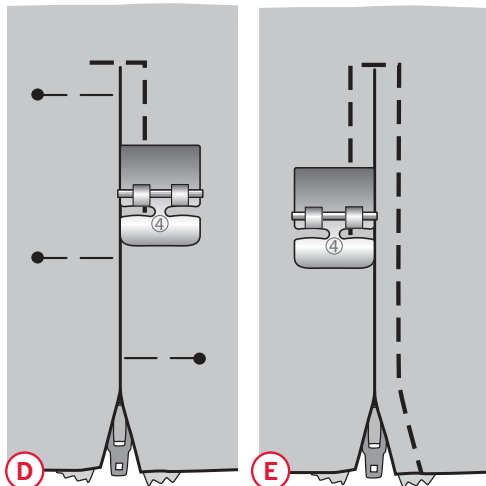

(D)

(E)

MAINTENANCE

Cleaning the Machine

To keep your sewing machine operating well, clean it often. No lubrication (oiling) is needed.

Wipe the exterior surface of your machine with a soft cloth to remove any dust or lint built up.

Cleaning the Bobbin Area



Note: Raise the needle, lower the feed dogs and turn off the machine.

Remove the presser foot. Push the bobbin cover release button (A) to the right and remove the bobbin cover (B) and the bobbin. Use the screwdriver to remove the two screws (C) in the stitch plate. Lift up the stitch plate.

Clean the feed dogs and the bobbin area with the brush found with the accessories.

Cleaning Under the Bobbin Area

Clean the area under the bobbin case after sewing several projects or any time you notice an accumulation of lint in the bobbin case area.

Remove the bobbin case by lifting it up and to the right. Clean the area with the brush or with a dry cloth.

Put the bobbin case back into the hook race so that the tip fits into the stopper (D).

Note: Do not blow air into the bobbin case area. The dust and lint will be blown into your machine.

Replacing the Stitch Plate

With the feed dogs lowered, replace the stitch plate, insert and tighten the two stitch plate screws.

Replace the bobbin cover. Raise the feed dogs.

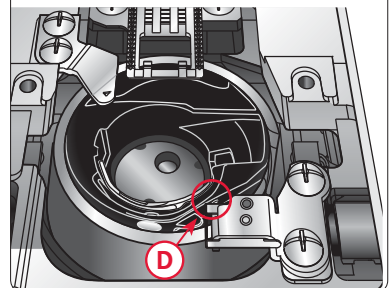
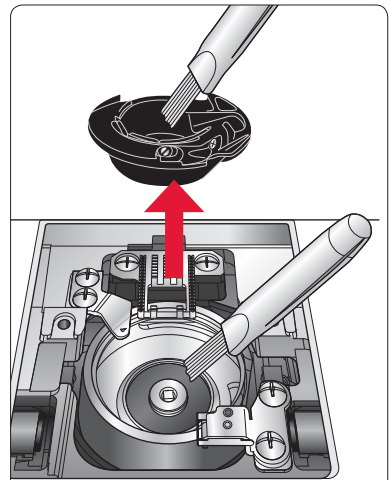
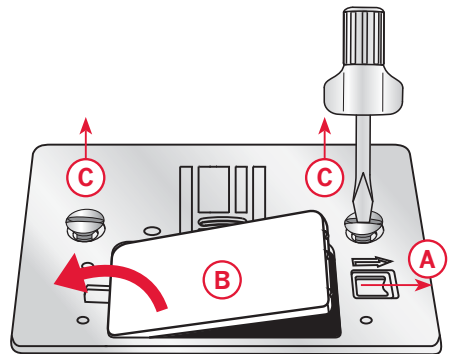

TROUBLESHOOTING

In this troubleshooting guide you will find solutions to the problems you may have with your machine. For further information please contact your local authorized PFAFF® dealer.

General Problems

Fabric does not move?

Make sure that the feed dogs are not lowered.

The needle breaks?

Insert needle correctly, see page 19.

Attach correct needle for the fabric.

The machine will not sew?

Check that all plugs are securely plugged into the machine and into the wall socket.

Push bobbin winder lever to sewing position.

The Machine does not Feed or Feeds Irregularly

Did you thread the machine properly?

Check how the machine is threaded.

Has sewing lint collected between the feed dogs?

Remove the stitch plate and clean the feed dogs with a brush.

The Machine Skips Stitches

Did you insert the needle properly?

Insert needle correctly, see page 19.

Did you insert a wrong needle?

Use needle system 130/705 H.

Did you thread the machine properly?

Check how the machine is threaded.

Is the correct presser foot used?

Attach correct presser foot.

Is the needle too small for the thread?

Make sure the needle is correct for the thread and fabric.

The Seam has Uneven Stitches

Is the thread tension correct?

Check needle thread tension and the threading.

Are you using too thick or slubbed thread?

Change the thread.

Is the bobbin thread evenly wound?

Check bobbin winding.

Is a correct needle used?

Insert a proper needle correctly, see page 19.

Needle Thread Breaks

Did you insert the needle properly?

Insert needle correctly, see page 19.

Did you insert a wrong needle?

Use needle system 130/705 H.

Is the needle bent or blunt?

Insert a new needle.

Did you thread the machine properly?

Check how the machine is threaded.

Is the needle too small for the thread?

Change the needle to the proper size for the thread.

Are you using poor thread with slubs or thread which has become dry?

Change to a new higher quality thread purchased from an authorized PFAFF® dealer.

Is a correct spool cap used?

Attach a spool cap of the right size for the actual thread spool.

Is the stitch plate hole damaged?

Change the stitch plate.

Bobbin Thread Breaks

Did you insert the bobbin properly?

Check the bobbin thread.

Is the stitch plate hole damaged?

Change the stitch plate.

Is the bobbin area clean?

Clean lint from bobbin area.

Is the bobbin wound correctly?

Wind a new bobbin.



We reserve the right to change the machine equipment and the assortment of accessories without prior notice, or make modifications to the performance or design.

Such modifications, however, will always be to the benefit of the user and the product.

Intellectual Property

PFAFF and SMARTER BY PFAFF are trademarks of
KSIN Luxembourg II, S.ar.l.



Please note that on disposal, this product must be safely recycled in accordance with relevant National legislation relating to electrical/electronic products. Do not dispose of electrical appliances as unsorted municipal waste, use separate collection facilities. Contact your local government for information regarding the collection systems available. When replacing old appliances with new ones, the retailer may be legally obligated to take back your old appliance for disposal free of charge.

If electrical appliances are disposed of in landfills or dumps, hazardous substances can leak into the groundwater and get into the food chain, damaging your health and well-being.

CE - Authorised Representative

VSM Group AB, SVP Worldwide
Drottningatan 2, SE-56184, Huskvarna, SWEDEN

