

**SINGER®**

# 14T967DC Overlock Workbook

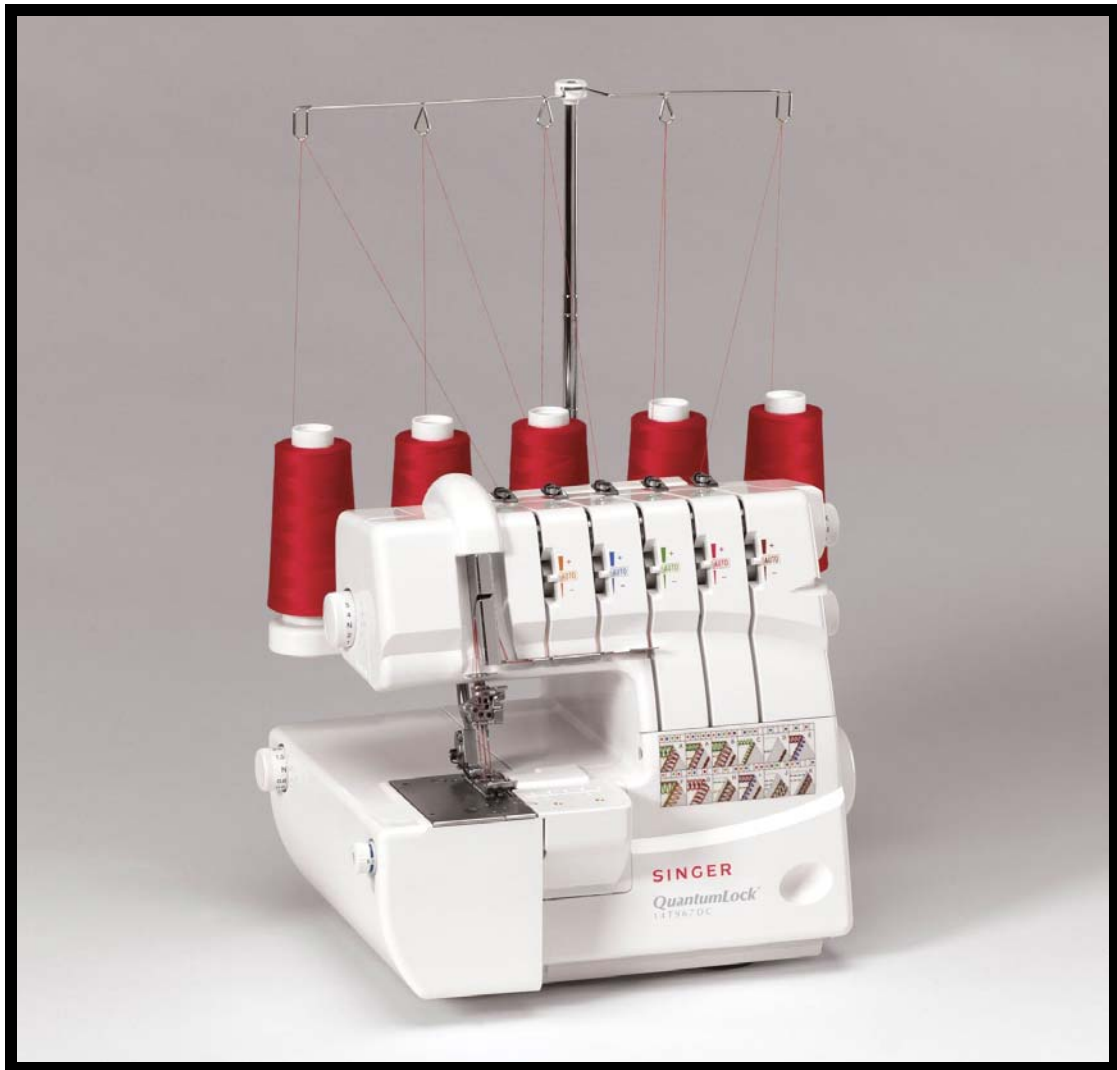

# SINGER®

Congratulations on the purchase of your new SINGER® Quantumlock® Overlock Machine! The Quantumlock® 14T967DC is a time saving innovation that provides professional seams, seam finishes, and creative stitch capabilities. Sew one-of-kind projects with the special effects of decorative stitching, such as Flatlocking, Chainstitching and Rolled Hemming. The overlock works side by side with your conventional sewing machine and adds new creative possibilities to your sewing projects.



This workbook has been created as a tool for learning the various stitch types, which you can then apply to your projects. The workbook is divided into fourteen individual sections, and each section focuses on a particular stitch type. Each section has comprehensive machine set-up and threading directions, photos and definitions on how and where the stitch can be used, and suggestions for successful stitch formation. It is a good starting point to fully understanding your Quantumlock® overlock.



We are certain that your creativity will be inspired, and that you will have many hours of sewing enjoyment with this easy-to-use machine, feature-packed machine!

Enjoy!

The SINGER® Education Department

**SINGER®**

# Table of Contents

**Stitch Types:**

Double Chain Stitch

Two-Thread Wrapped Edge Overlock (narrow and wide)

Two-Thread Overedge (narrow and wide)

Three-Thread Overlock  
(narrow, wide, and wide with decorative threads)

Three-Thread Flatlock (narrow and wide)

Three-Thread Ultra-Stretch Mock Safety Stitch

Four-Thread Ultra-Stretch Mock Safety Stitch

Four-Thread Safety Stitch

Five-Thread Safety Stitch Wide

Five-Thread Safety Stitch Narrow

Cover Stitch Narrow

Cover Stitch Wide

Triple Cover Hem Stitch

Three-Thread Rolled Hem

## Double Chain Stitch

This stitch is suitable for straight seams. It also can be used for a decorative chainstitch topstitching effect. The Middle Cover needle and the Chainstitch Looper are used. Decorative thread can be placed in the Chainstitch Looper, the needle, or in both to create various effects.



## Set up:

### Needle:

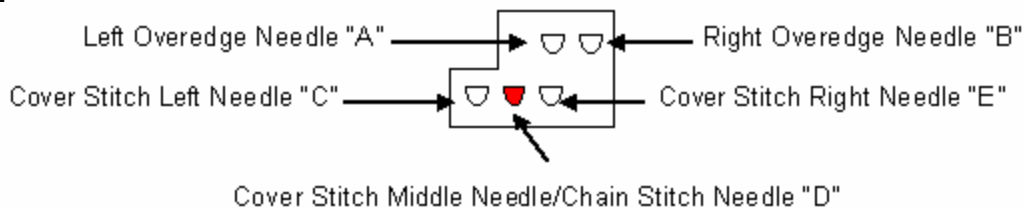

### Set at::

<b>ATD:</b> Auto Tension Dial	"D"
Left Cover Stitch Needle "C"	Unthreaded and Remove Needle
Middle Cover Stitch Needle "D" (Blue)	Threaded
Right Cover Stitch Needle "E"	Unthreaded and Remove Needle
Overedge Left Needle "A"	Unthreaded and Remove Needle
Overedge Right Needle "B"	Unthreaded and Remove Needle
Upper Looper	Looper Disengaged and Not Threaded
Spreader	Not Engaged
Lower Looper	Unthreaded
Chainstitch Looper (Brown)	Threaded
Upper Knife	Not Used
Seam Guide Plate	Installed
Seam Width Dial	"N"
Stitch Length Dial	"N"
Presser Foot Pressure	"N"
Differential Feed Dial	"N"
Stitch Finger	"R"

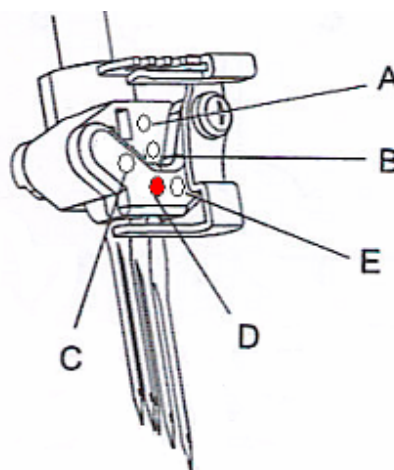

## Double Chain Stitch

- ◆ Turn Auto Tension Dial to “D”.



- ◆ Turn Stitch Length Dial to “N”.

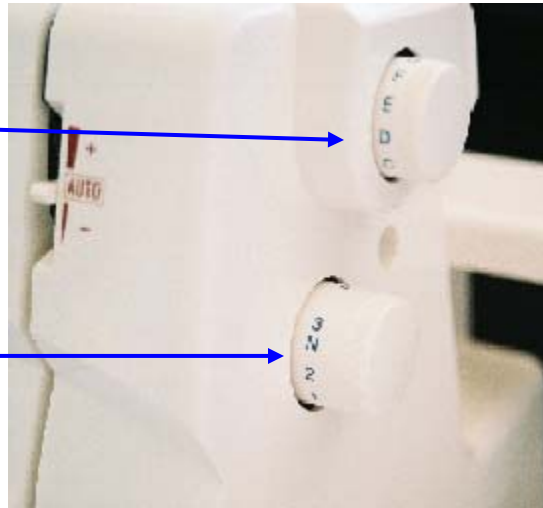

- ◆ Disengage Upper Knife. The knife will not trim the fabric when it is disengaged.
  1. Open Loper Cover.
  2. Pull the movable knife holder (silver screw) to the right as far as it will go.
  3. Turn the holder counter clockwise until the knife clicks into a lock position.

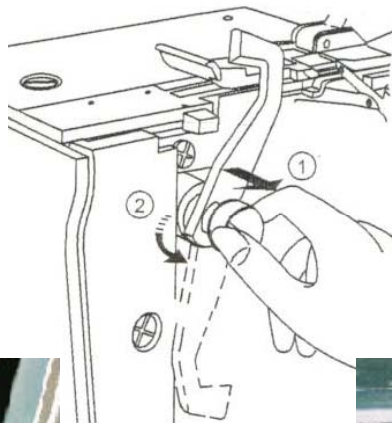

Upper Knife Engaged



Upper Knife Disengaged

# SINGER®

- ◆ Turn Presser Foot Pressure Dial to “N”.



- ◆ Turn Differential Feed Dial “N”.



- ◆ Turn Seam Width Dial to “N”.



- ◆ Place Stitch Finger to “R”.

# SINGER®

- ◆ Install the Seam Guide Plate. The Seam Guide Plate provides a flat surface for the fabric and seam guides. It can only be used when the knife and the lower looper are disengaged. The Seam Guide Plate is used when sewing the Chainstitch, Cover Stitch and the Triple Cover Stitch.

1. Open looper cover.
2. Remove Knife Cover by pulling it slightly towards you.
3. Slide the Seam Guide Plate into place.

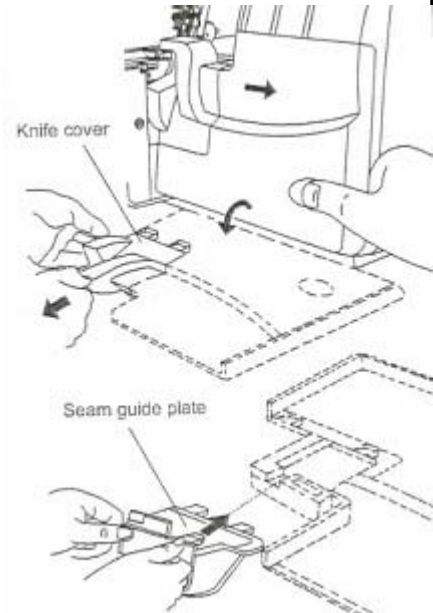

- ◆ Disengage Upper Looper. By disengaging the Upper Looper, the looper no longer moves when sewing. It is nonoperative. If the looper was still engaged, it would hit the Seam Guide Plate.

1. Turn handwheel until the Upper Looper is in the lowest position.
2. Push the clutch button to the left and up to disengage.

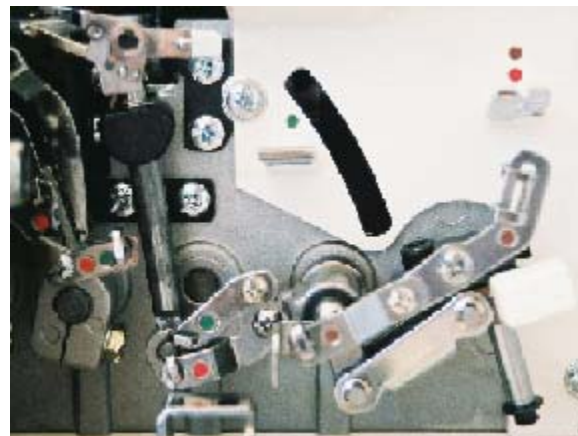
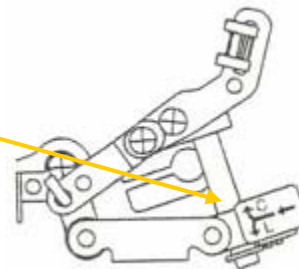
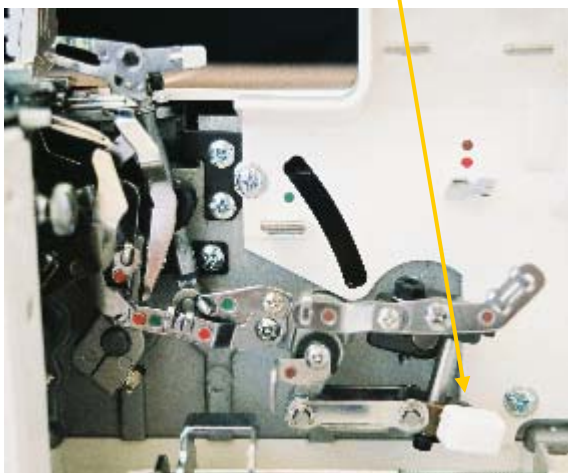

Upper Looper Disengaged



◆ Thread Chainstitch Looper with a decorative thread

1. Raise the Presser foot to release the tension disks. Pass the thread from the back to the front through the thread guide ①.

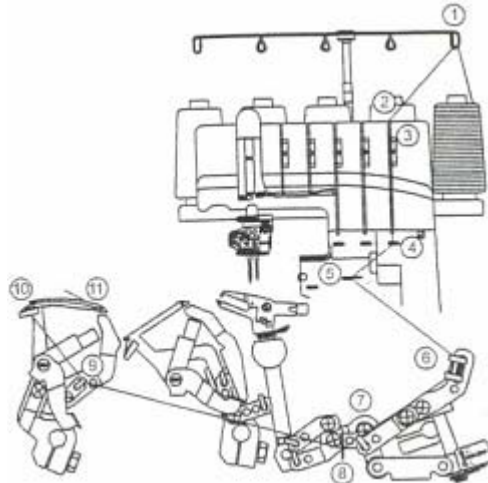
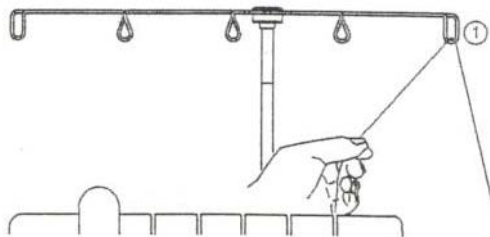

2. Thread the top cover thread guide by pulling the thread towards the left until it slips under the guide. Then pull thread along the right side of the button, as illustrated.

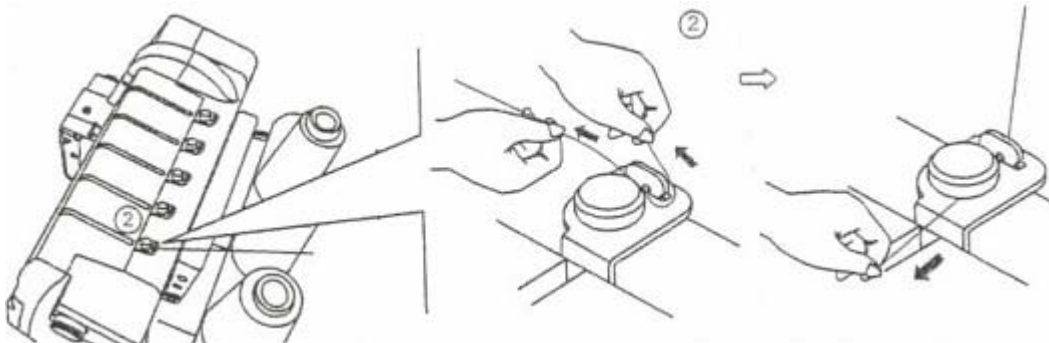

3. While holding the thread, firmly pull the thread between the tension disks.

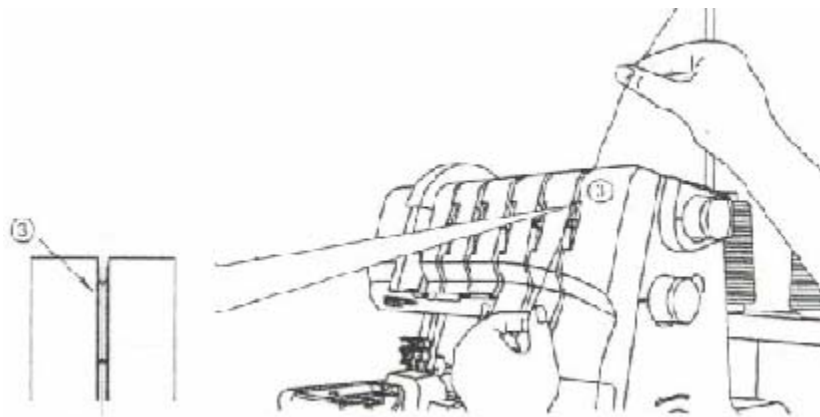

4. Turn the hand wheel toward you until the Chainstitch Looper extends out 10mm (approximately ½") from the needle plate edge.



5. Thread the looper area of the machine following the brown color-coded thread guides 4-11. Use the tweezers provided in the accessory case to aid in threading the looper.

6. Place the thread through threading guide ④ and ⑤.

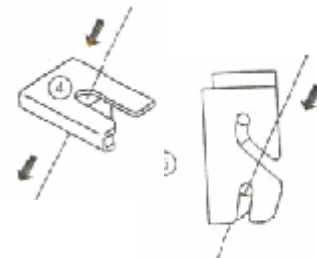

7. Continue threading guides ⑥, ⑦, ⑧ and ⑨.

8. Thread the looper eye (A) from front to back. Pull about 4 inches of thread through the looper. Position the thread into the V cutout (B) on the threader. Firmly hold the thread tail with your left hand and pull threader lever (C) up into place (D). Gently pull 5-6" of thread to the back of the machine.

⑩

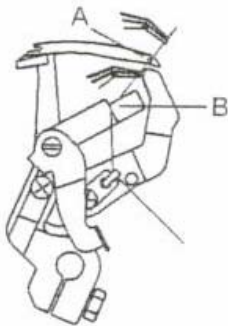

⑪

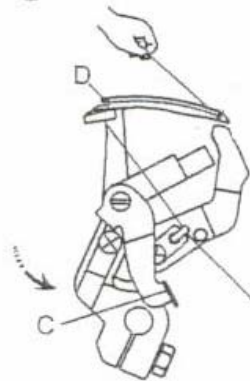

"V" cutout

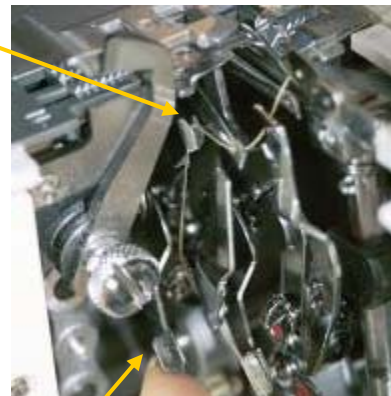

Threader lever

◆ Thread Middle Cover Stitch Needle with regular overlock thread.

1. Raise the Presser Foot to release the tension disks. Thread the Cover Stitch Middle/Chain Stitch needle as illustrated 1-9.
2. Pass thread from back to the front through the thread guide ①.

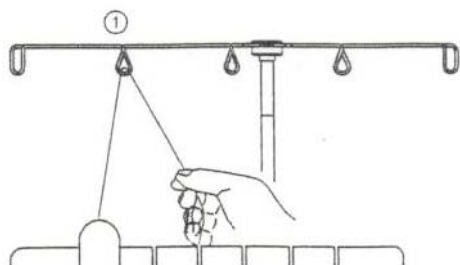
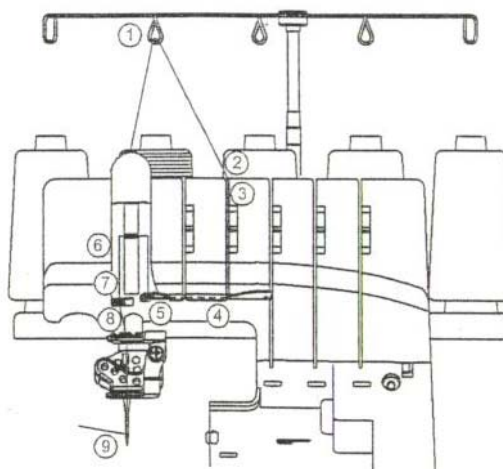

3. Thread the top cover thread guide by pulling the thread towards the left until it slips under the guide. Then pull the thread along the right side of the button as illustrated.

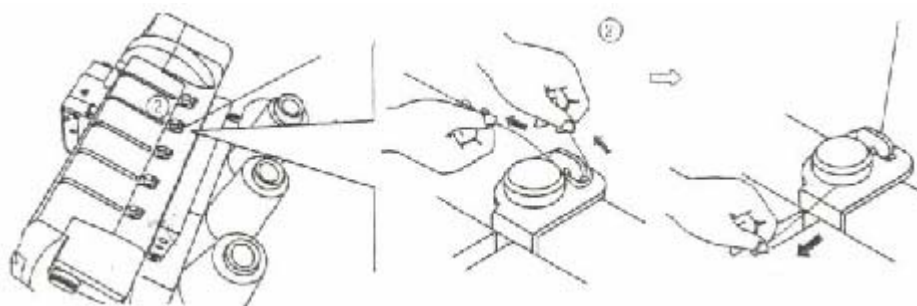

4. While holding the thread, firmly pull the thread between the tension disks.

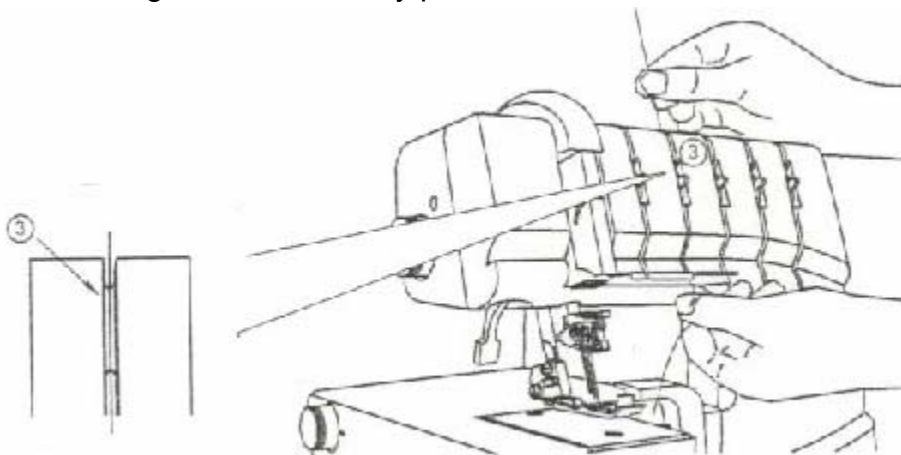

5. Continue to thread points 4-8. Slip the thread into the middle slot of the thread guide ⑤. Go over the take up lever ⑥. Continue by slipping the thread into the middle slot of the thread guides ⑦ and ⑧.
6. Before threading the eye of the needle, make sure the thread is in front of the thread guide located on the bottom of the needle clamp for the Cover Stitch or Chainstitch.

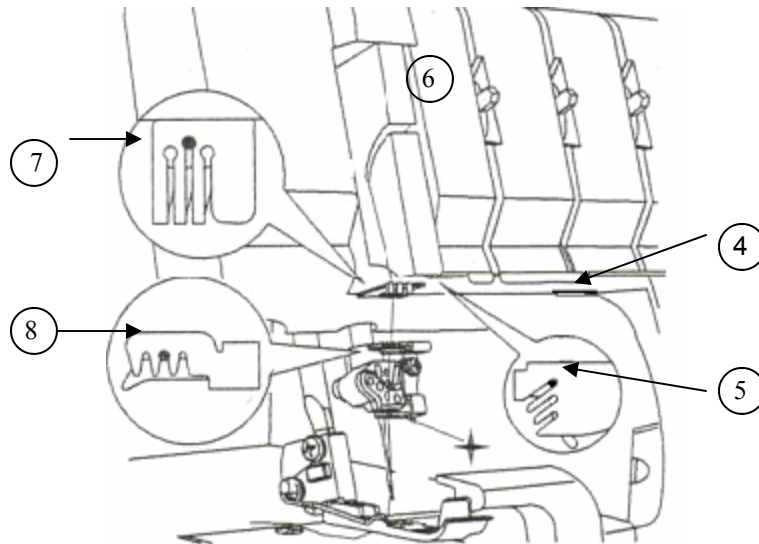

7. Thread the eye of the Middle Cover Needle ⑨.

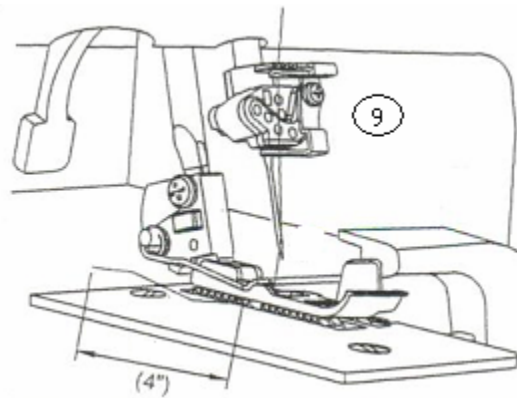
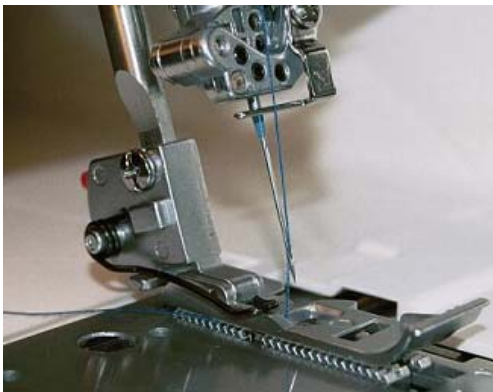

8. Draw about 4 inches of the thread through the needle eye towards the back of the machine.
9. Place the thread to the back, under the Presser Foot. Lower foot and sew.

## Try It:

- ◆ Fuse a layer of fabric to a lightweight batting.
- ◆ Fuse a fabric backing to the other side of the batting, to create a quilted piece of fabric.
- ◆ Using a rinse-away fabric marking pen draw a design lines on the wrong side of the fabric.

Make soft gentle turns; gradual curves work best. Avoid making sharp corners.

- ◆ Lift the Presser Foot to the highest position.
- ◆ Position the fabric right side down. Align the needle with one of the lines drawn.
- ◆ Lower the Presser Foot and sew.
- ◆ The decorative thread will be on the under side.



- ◆ When sewing the Double Chainstitch, it is necessary to have fabric under the needle. Avoid sewing off the fabric.
- ◆ Continue sewing, following the drawn marking.
- ◆ To remove fabric, gently turn handwheel to loosen threads.
- ◆ Turn fabric over to see the decorative stitching.



## Two-Thread Wrapped Edge Overlock (Narrow)

The Two-Thread Wrapped Edge Overlock provides an elegant fine finish to lightweight fabrics. When using clear threads in conjunction with the Two-Thread stitch, the fabric appears to have an invisible edge. This gives a couture effect and looks beautiful on finer fabrics. The Two-Thread Stitch requires the lower looper thread and one overlock needle thread. The lower looper thread wraps around the fabric's edge. There are 2 different ways to set up for a Two-Thread Wrapped Edge Overlock stitch. For a more narrow stitch (4.0) select the right overedge needle; for a wider stitch(6.0) the left overedge needle is used.



Right Overedge  
Needle Thread

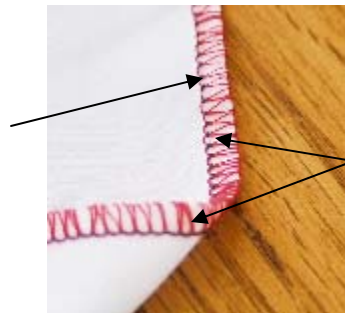

Lower Loper  
Thread

## Set up:

### Needle:

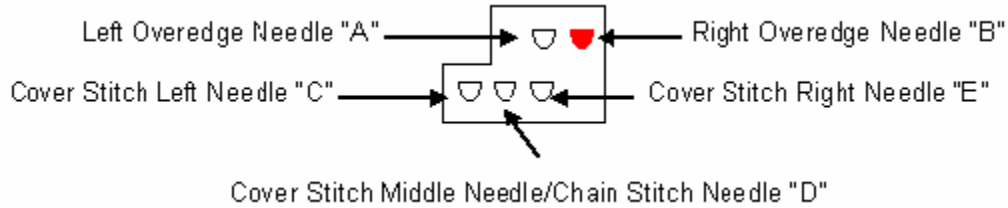

### Set at:

<b>ATD:</b> Auto Tension Dial	"D"
Left Cover Stitch Needle "C"	Unthreaded and Remove Needle
Middle Cover Stitch Needle "D"	Unthreaded and Remove Needle
Right Cover Stitch Needle "E"	Unthreaded and Remove Needle
Overedge Left Needle "A"	Unthreaded and Remove Needle
Overedge Right Needle (Blue) "B"	Threaded
Upper Looper	Looper Engaged and Not Threaded
Spreader	Engaged
Lower Looper (Red)	Threaded
Chain Stitch Looper (Brown)	Not Threaded
Upper Knife	Engaged
Seam Guide Plate	Not Installed Use Knife Cover
Seam Width Dial	"N"
Stitch Length Dial	"2"
Presser Foot Pressure	"N"
Differential Feed Dial	"N"
Stitch Finger	"N"

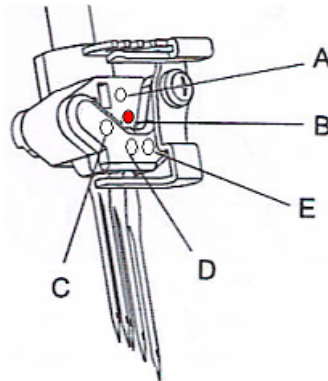



- ◆ Turn Auto Tension Dial to “D”.

- ◆ Turn Stitch Length Dial to “2”.

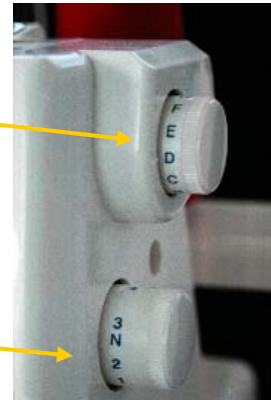

- ◆ Engage Upper Knife. The knife will not trim the fabric when it is disengaged.
  1. Open Looper Cover.
  2. Pull the movable knife holder (silver screw) to the right as far as it will go.
  3. Turn the holder toward clockwise until the knife clicks into a lock position.

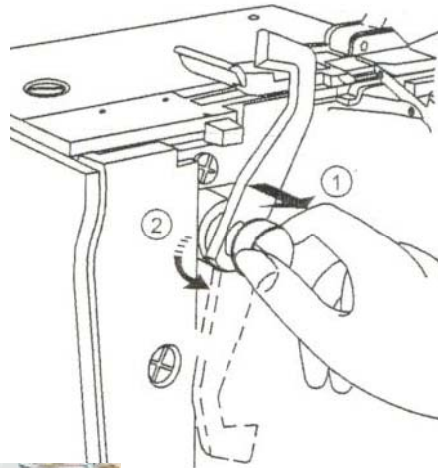

Upper Knife Disengaged



Upper Knife Engaged

- ◆ Turn Presser Foot Pressure Dial to “N”.



- ◆ Turn Differential Feed Dial to “N”.



- ◆ Turn Seam Width Dial to “N”.

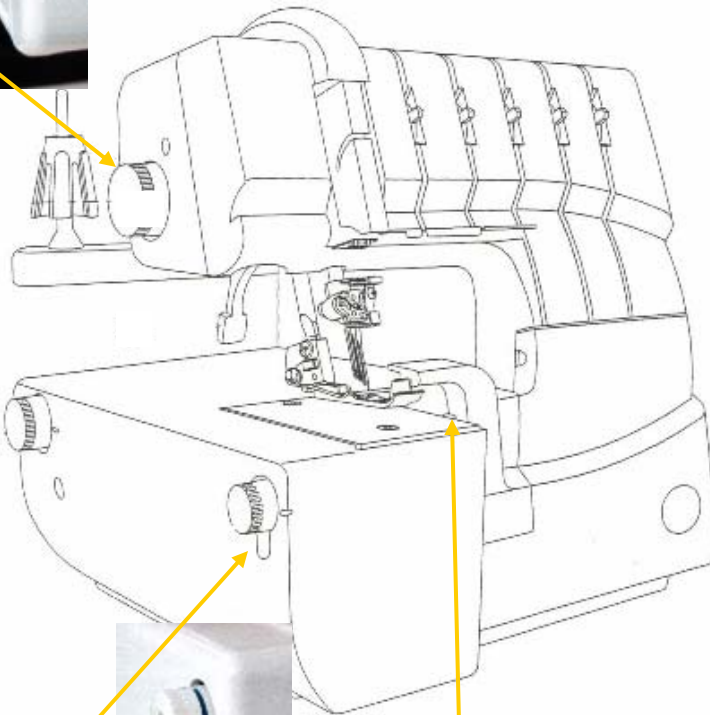

- ◆ Set Stitch Finger to “N”.

◆ Install the Knife Cover.

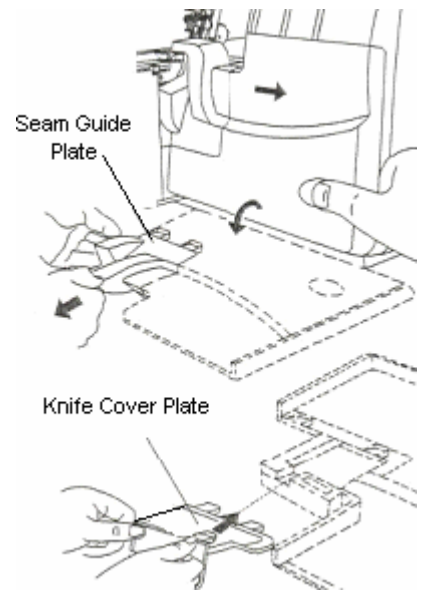

◆ Engage Upper Looter. Engaging the Upper Looter causes the looper to move when sewing. Even though the Upper Looter is not threaded, it needs to be engaged.

1. Push the clutch button to the left and down to engage.
2. Turn handwheel.

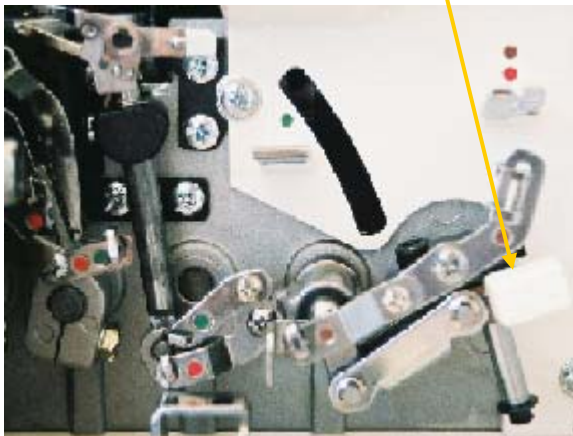

Upper Looter Disengaged

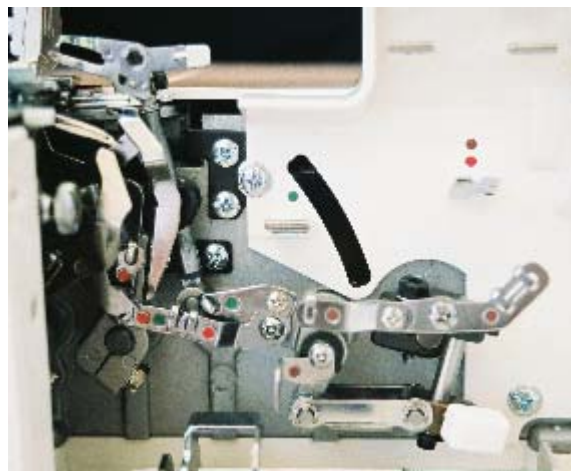
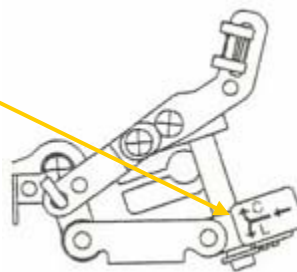

Upper Looter Engaged

- ◆ Engage Spreader. The Upper Loper has a hole for the thread on the top of the looper. If the stitch requires that the looper be engaged, but not threaded then the Spreader is used. The Spreader simply plugs-in (or closes) the looper's hole. The Spreader is disengaged when the Upper Loper is engaged/operative and threaded. The Spreader is used with a stitch that requires only one looper thread. With the help of the Spreader the single looper thread needs to wrap around the fabric's edge.

1. Raise the white handle on the Spreader to insert the tip into the eye of the Upper Loper.

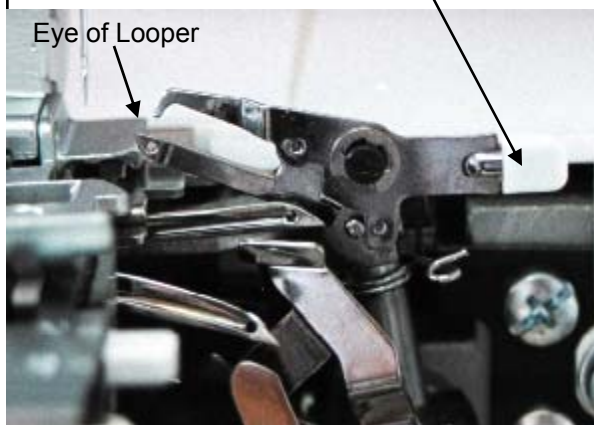

Spreader Disengaged



Spreader Engaged

- ◆ Thread Lower Loper with regular overlock thread.

1. Raise the Presser Foot to release the Tension disks. Thread the Lower Loper as illustrated 1-10.
2. Pass thread from back to the front through the thread guide ①.

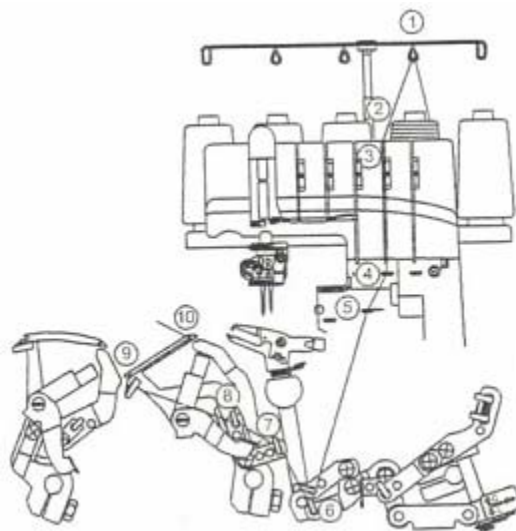
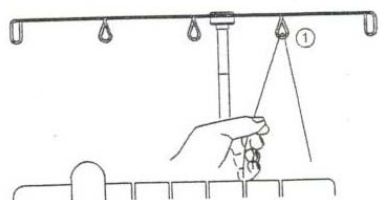

3. Thread the top cover thread guide by pulling the thread towards the left until it slips under the guide. Then pull the thread along the right side of the button as illustrated.

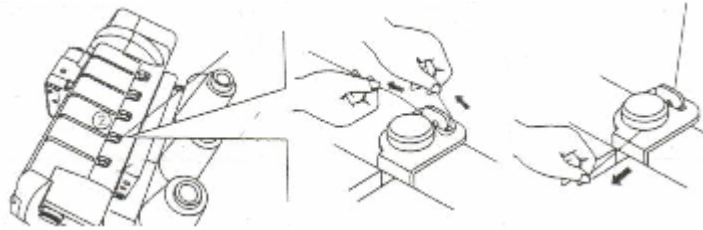

4. While holding the thread firmly, pull the thread between the tension disks.

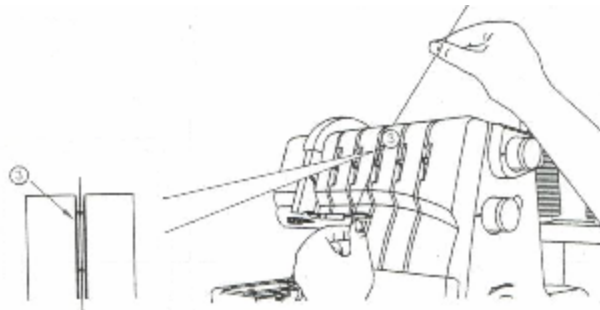

5. Turn the handwheel toward you until the lower looper extends 5-10mm (approximately 1/2 inch) from the needle plate edge.

6. Thread the looper area of the machine following the red color coded thread guides 4-10.

7. Place the thread slightly from left and to the right of threading guide ④.

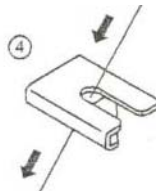

8. Place the thread slightly from the front and to the back of threading guide ⑤.



9. Place the thread through ⑥, ⑦, and ⑧.

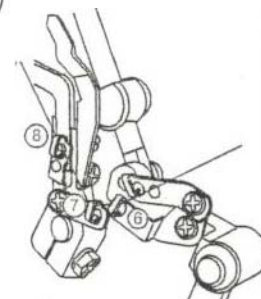

10. Thread the looper eye (A) from front to back. Pull about 4 inches of thread. Position thread into V cutout (B) on threader. Firmly hold thread tail with left hand and pull Threader lever (C) up into place (D).

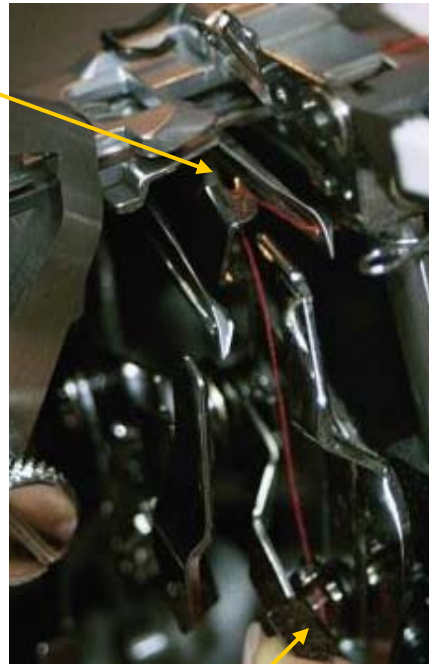
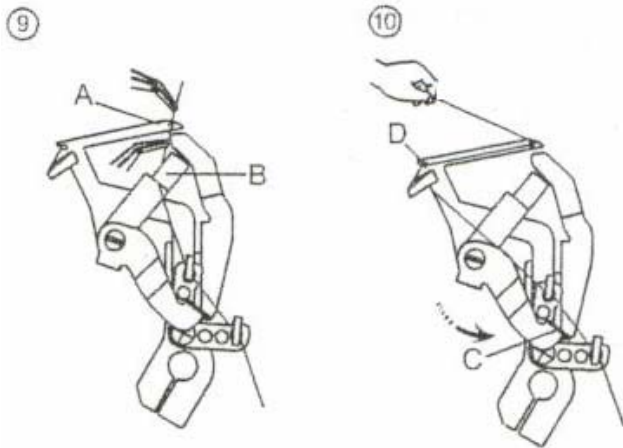

Threader Lever

◆ Thread Right Overedge needle with regular thread.

1. Raise the Presser Foot to release the tension discs. Thread the right needle as illustrated 1-9.
2. Pass thread from back to the front through the thread guide ①.

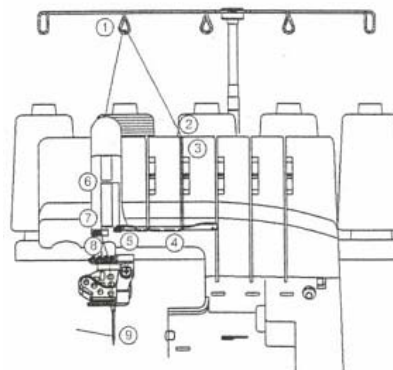
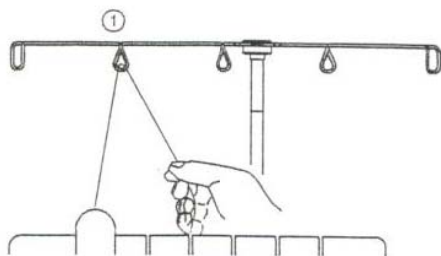

3. Thread the top cover thread guide by pulling the thread towards the left until it slips under the guide. Then pull the thread along the right side of the button as illustrated.

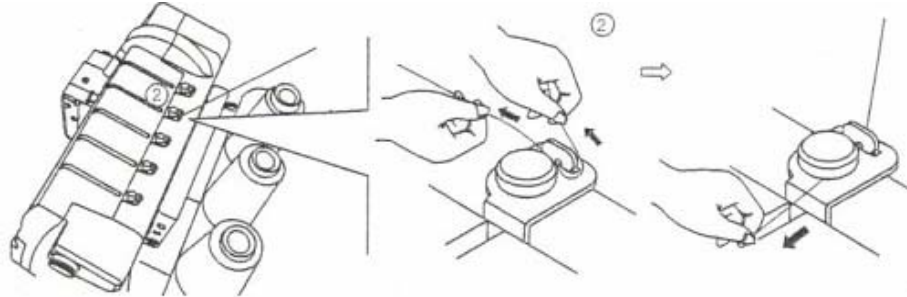

4. Continue to thread points 4-8. Slip the thread into the rear slot of the thread guide ⑤. Go over the take up lever ⑥. Continue by slipping the thread into the right slot of the thread guides ⑦ and ⑧.

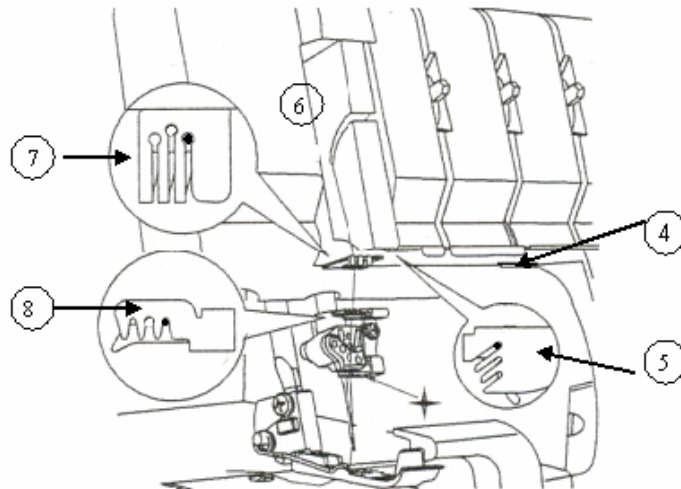

5. Before threading the eye of the needle, make sure the thread is behind the thread guide located on the bottom of the needle clamp.

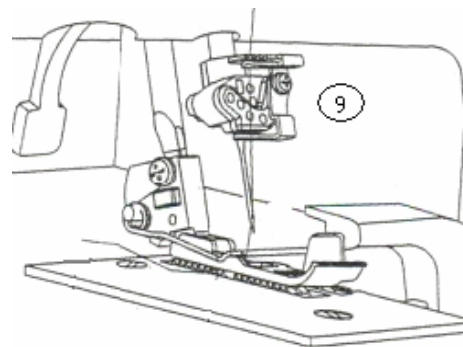
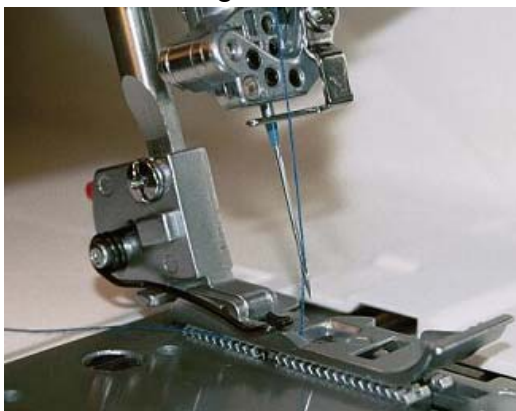

6. Thread the eye of the Right Overedge Needle ⑨.

# SINGER®

## Try It:

- ◆ Align two pieces of lightweight fabric, right sides together so that the knife just slightly trims the fabric edge.
- ◆ Sew.
- ◆ Press seam to one side.





## Two-Thread Wrapped Edge Overlock (Wide)

The Two-Thread Wrapped Edge Overlock (wide) has the same set up as the Two-Thread Wrapped Edge Overlock (narrow) Stitch. The only exception is the Right Overedge Needle is now unthreaded and removed and the Left Overedge Needle is threaded. By using the left needle the stitch becomes wider.

### Set up:

#### Needle:

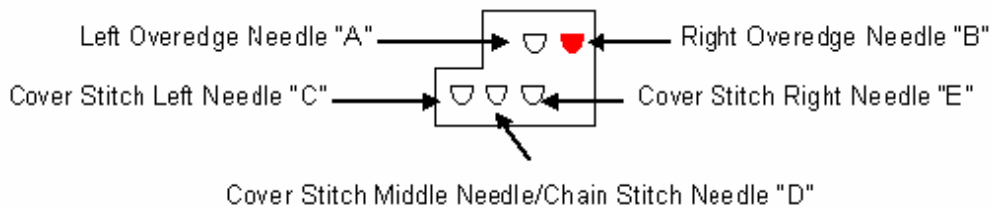

Set at:

<b>ATD:</b> Auto Tension Dial	"D"
Left Cover Stitch Needle (Orange)	Unthreaded and Remove Needle
Middle Cover Stitch Needle (Blue)	Unthreaded and Remove Needle
Right Cover Stitch Needle (Green)	Unthreaded and Remove Needle
Overedge Left Needle (Orange)	Threaded
Overedge Right Needle (Blue)	Unthreaded and Remove Needle
Upper Looper (Green)	Looper Engaged and Not Threaded
Spreader	Engaged
Lower Looper (Red)	Threaded
Chain Stitch Looper (Brown)	Not Threaded
Upper Knife	Engaged
Seam Guide Plate	Not Installed Use Knife Cover
Seam Width Dial	"N"
Stitch Length Dial	"2"
Presser Foot Pressure	"N"
Differential Feed Dial	"N"
Stitch Finger	"N"

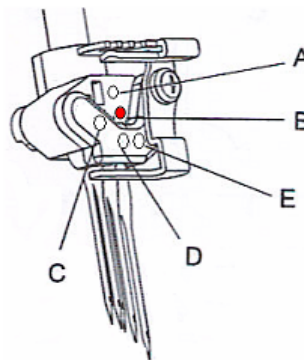

Right Overedge Needle Thread



Left Overedge Needle Thread

◆ Thread Left Overedge needle with regular thread.

1. Raise the Presser Foot to release the tension disks. Thread the left needle as indicated 1-9.

2. Pass thread from back to the front through the thread guide ①.

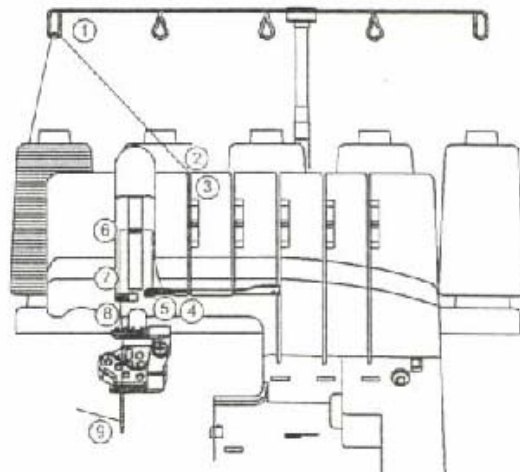
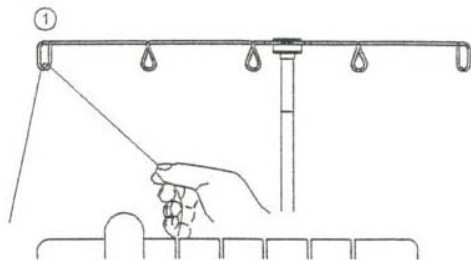

3. Thread the top cover thread guide by pulling the thread towards the left until it slips under the guide. Then pull the thread along the right side of the button as illustrated.

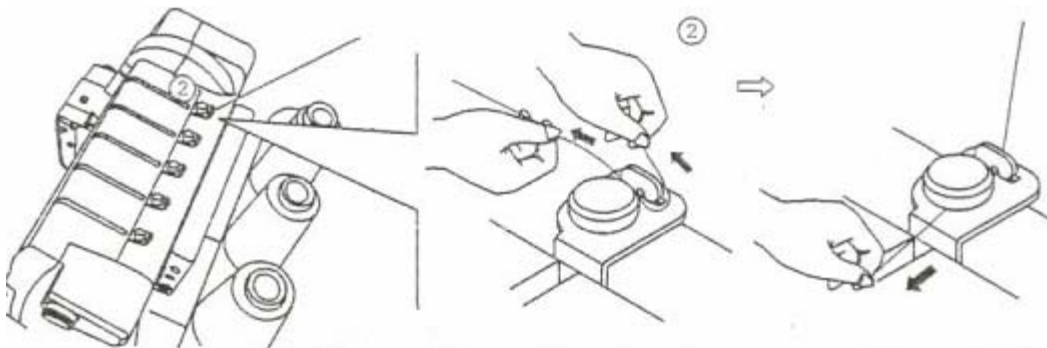

4. While holding the thread firmly, pull the thread between the tension disks.

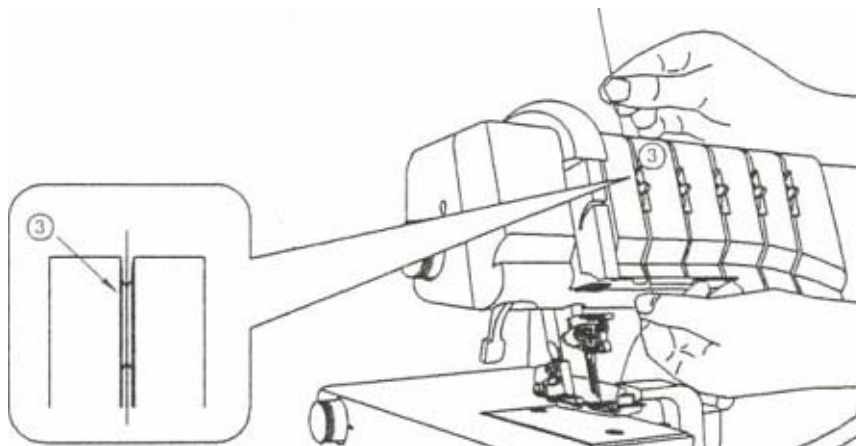

5. Continue to thread points 4-8. Slip the thread into the middle slot of the thread guide ⑤. Go over the take up lever ⑥. Continue by slipping the thread into the middle slot of the thread guides ⑦ and ⑧.
6. Before threading the eye of the needle, make sure the thread is behind the thread guide located on the bottom of the needle clamp.

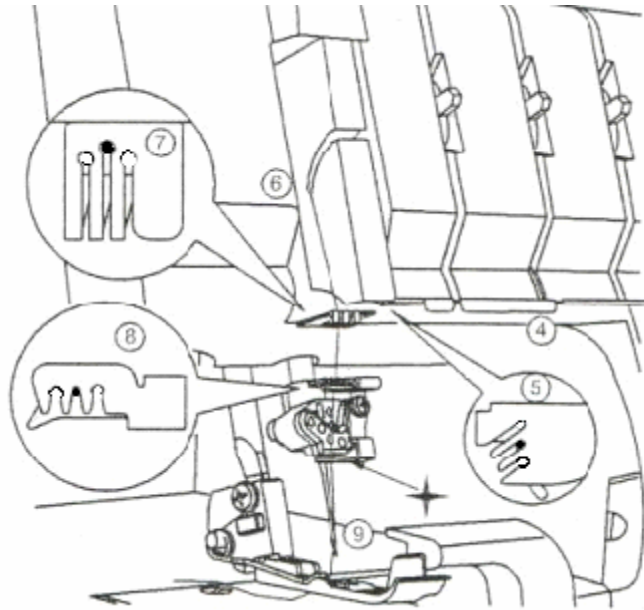

7. Thread the eye of the Left Overedge needle ⑨.
8. Draw about 4 inches of the thread through the needle eye towards the back of the machine.
9. Place the thread to the back, under the Presser Foot.

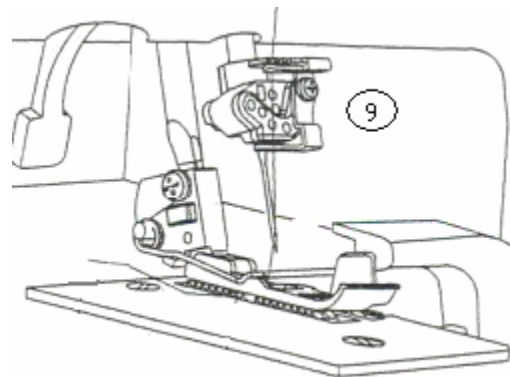

# SINGER®

## Try It:

- ◆ Align one piece of medium weight fabric so that the knife just slightly trims the fabric edge.
- ◆ Sew.



## Two-Thread Overedge (Narrow)

This stitch is used as a lightweight seam finish or a lightweight seam. When creating a seam finish, less thread is used and the thread does not imprint on the right side of the fabric when pressed. The stitch can also be used for seaming. The stitch creates less bulky seams, which is ideal for sheer or lace fabrics. The Two-Thread Overlock stitch requires the lower looper thread and one overlock needle thread. There are 2 different ways to set up for a Two-Thread Overlock stitch. For a more narrow stitch (4.0) select the right overedge needle and for a wider stitch (6.0) the left overedge needle is used.

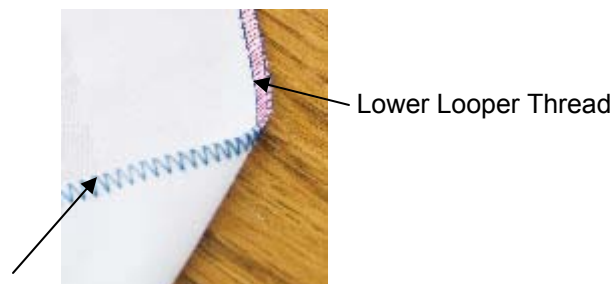

Right Overedge Needle Thread

## Set up:

### Needle:

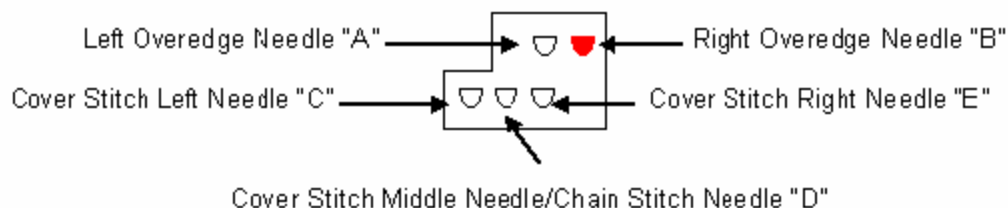

### Set at:

ATD: Auto Tension Dial	"E"
Left Cover Stitch Needle "C"	Unthreaded and Remove Needle
Middle Cover Stitch Needle "D"	Unthreaded and Remove Needle
Right Cover Stitch Needle "E"	Unthreaded and Remove Needle
Overedge Left Needle "A"	Unthreaded and Remove Needle
Overedge Right Needle "B" (Blue)	Threaded
Upper Looper	Looper Engaged and Not Threaded
Spreader	Engaged
Lower Looper (Red)	Threaded
Chain Stitch Looper (Brown)	Not Threaded
Upper Knife	Engaged
Seam Guide Plate	Not Installed Use Knife Cover
Seam Width Dial	"N"
Stitch Length Dial	"N"
Presser Foot Pressure	"N"
Differential Feed Dial	"N"
Stitch Finger	"N"

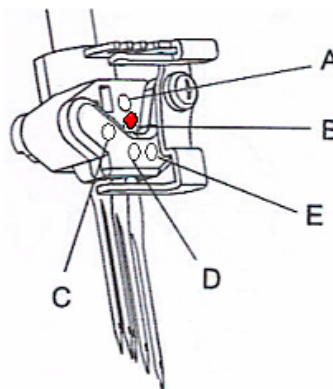

- ◆ Turn Auto Tension Dial to “E”.

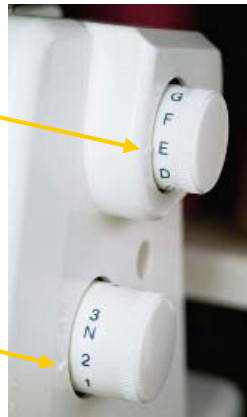

- ◆ Turn Stitch Length Dial to “2”.

- ◆ Engage Upper Knife.

The knife will not trim the fabric when it is disengaged.

1. Open Looper Cover.
2. Pull the movable knife holder (silver screw) to the right as far as it will go.
3. Turn the holder clockwise until the knife clicks into a lock position.

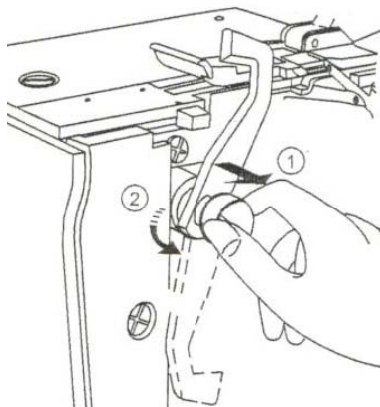

Upper Knife Disengaged



Upper Knife Engaged

- ◆ Turn Presser Foot Pressure Dial to “N”.



- ◆ Turn Differential Feed Dial to “N”.



- ◆ Turn Seam Width Dial to “N”.



- ◆ Set Stitch Finger to “N”.





◆ Install the Knife Cover.

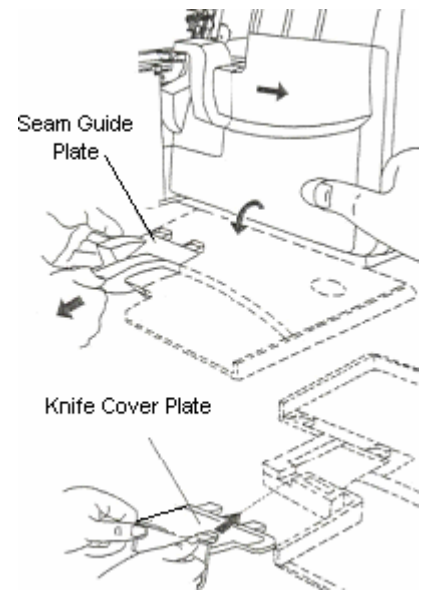
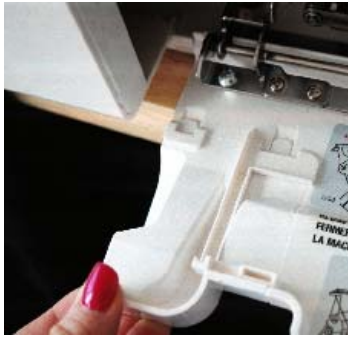

◆ Engage Upper Looper. Engaging the Upper Looper causes the looper to move when sewing. Even though the Upper Looper is not threaded, it needs to be engaged.

1. Push the clutch button to the left and down to engage.
2. Turn handwheel.

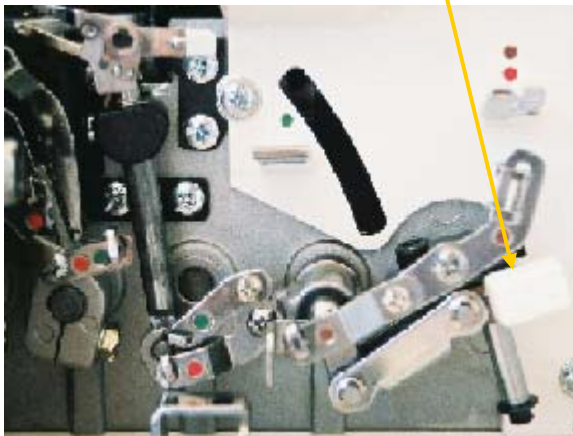
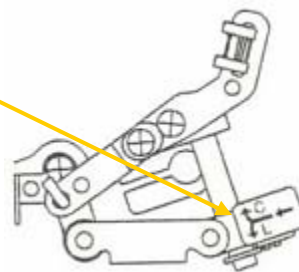

Upper Looper Disengaged

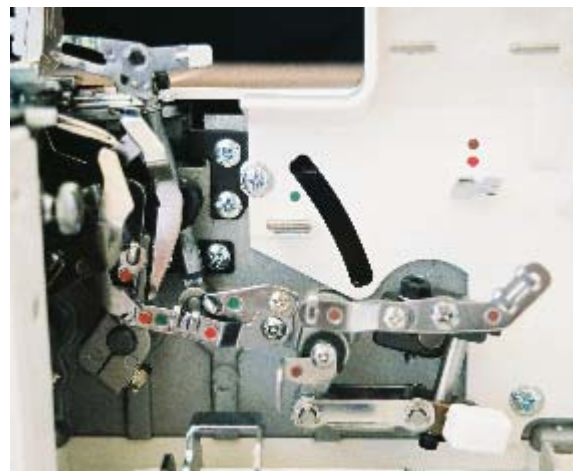

Upper Looper Engaged

- ◆ Engage Spreader. The Upper Looter has a hole for the thread on the top of the looper. If the stitch requires that the looper be engaged but not threaded, then the Spreader is used. The Spreader simply plugs-in (or closes) the looper's hole. The Spreader is disengaged when the Upper Looter is engaged/operative and threaded. The Spreader is used with a stitch that requires only one looper thread. With the help of the Spreader, the single looper thread wraps around the fabric's edge.

1. Raise the white handle on the spreader to insert the tip into the eye of the Upper Looter.

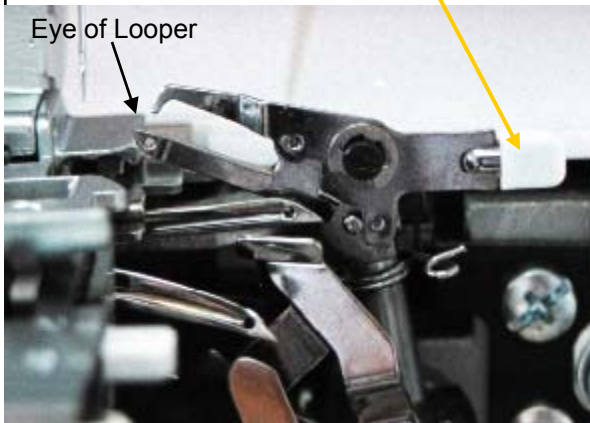

Spreader Disengaged



Spreader Engaged

- ◆ Thread Lower Looter with regular overlock thread.

1. Raise the Presser Foot to release the tension disks. Thread the Lower Looter as illustrated 1-10.
2. Pass thread from back to the front through the thread guide ①.

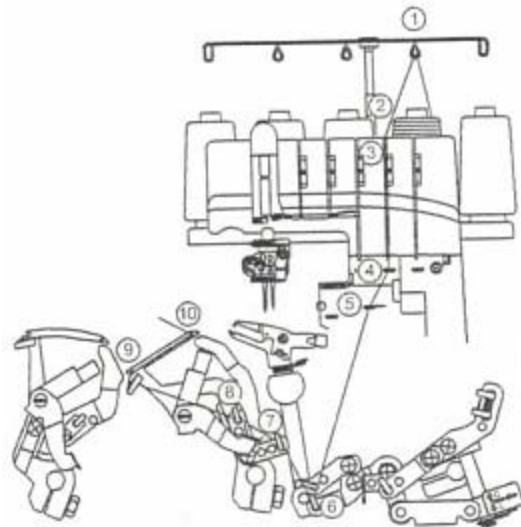
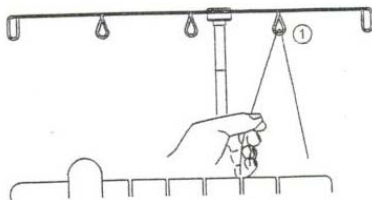

3. Thread the top cover thread guide by pulling the thread towards the left until it slips under the guide. Then pull the thread along the right side of the button as illustrated.

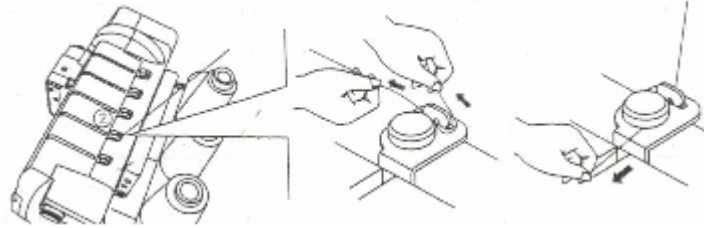

4. While holding the thread firmly, pull the thread between the tension disks.

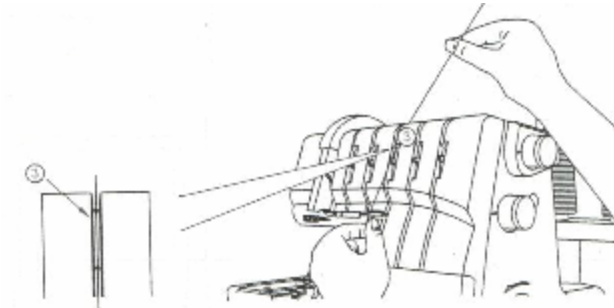

5. Turn the handwheel toward you until the lower looper extends 5-10mm (approximately 1/2") from the needle plate edge.
6. Thread the looper area of the machine following the red color coded thread guides 4-10.

7. Place the thread slightly from left and to the right of threading guide ④.

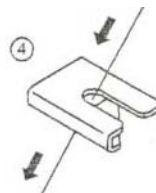

8. Place the thread slightly from the front and to the back of threading guide ⑤.

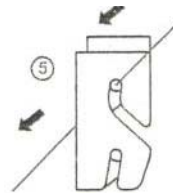

9. Place the thread through ⑥, ⑦, and ⑧.

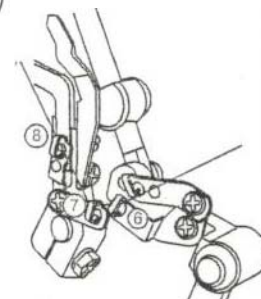

10. Thread the looper eye (A) from front to back. Pull about 4 inches of thread. Position thread into V cutout (B) on threader. Firmly hold thread tail with left hand and pull Threader Lever (C) up into place (D).

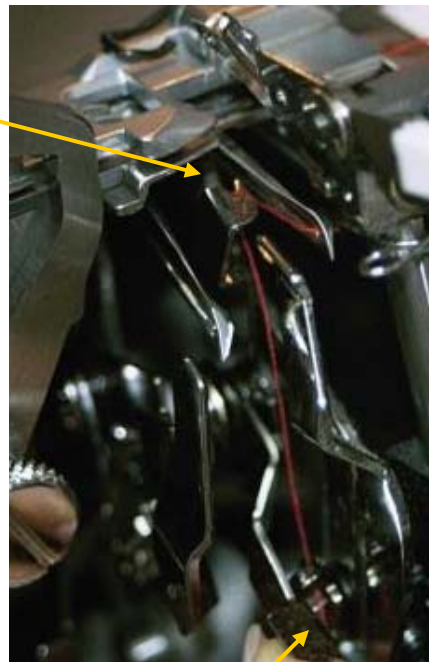
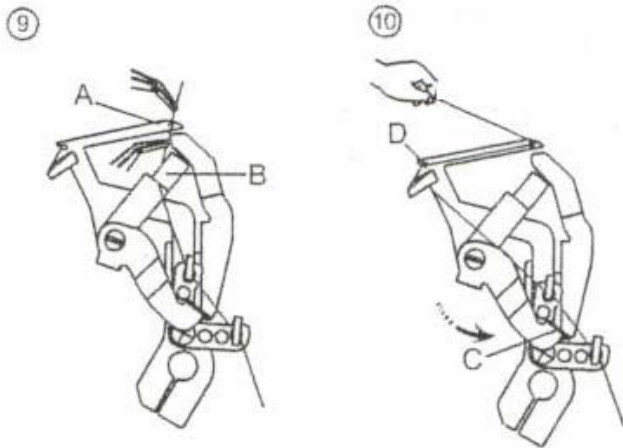

Threader Lever

◆ Thread Right Overedge needle with regular thread.

1. Raise the Presser Foot to release the tension disks. Thread the right needle as indicated 1-9.
2. Pass thread from back to the front through the thread guide ①.

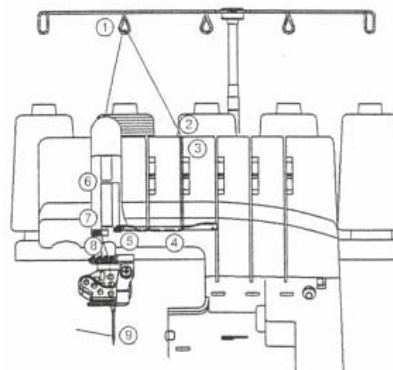
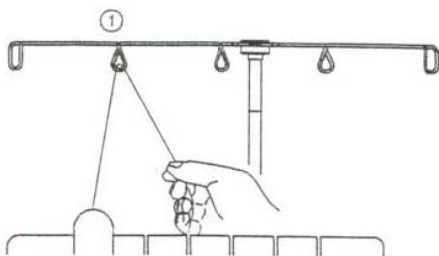

3. Thread the top cover thread guide by pulling the thread towards the left until it slips under the guide. Then pull the thread along the right side of the button as illustrated.

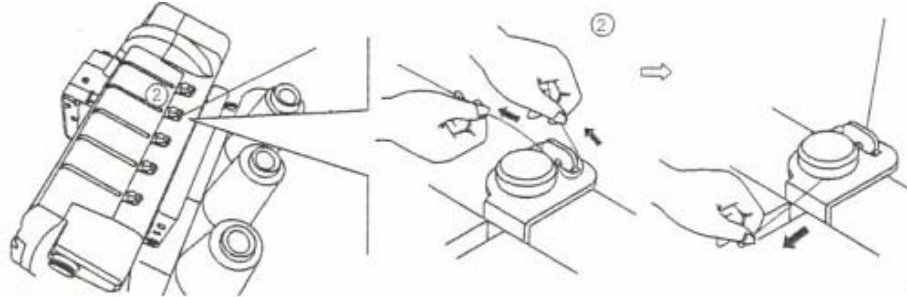

4. Continue to thread points 4-8. Slip the thread into the rear slot of the thread guide ⑤. Go over the take up lever ⑥. Continue by slipping the thread into the right slot of the thread guides ⑦ and ⑧.

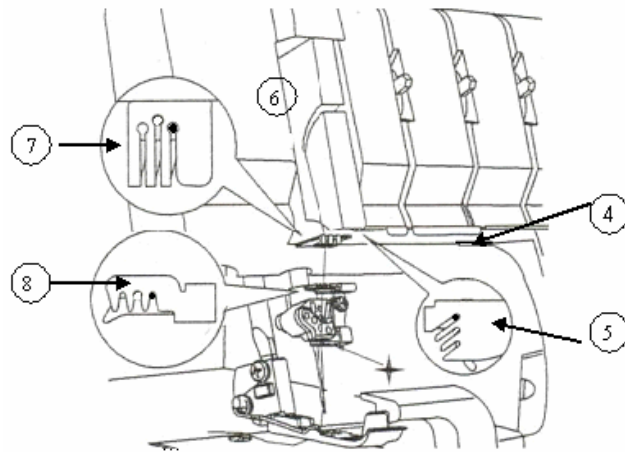

5. Before threading the eye of the needle, make sure the thread is behind the thread guide located on the bottom of the needle clamp.

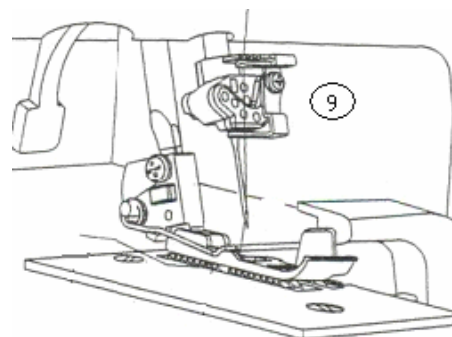

6. Thread the eye of the Overedge Right Needle ⑨.

# SINGER®

## Try It:

- ◆ Join two pieces of medium weight fabric, right sides together with a conventional sewing machine straight stitch.
- ◆ Finish the edges of both fabric pieces by aligning the fabric edge so that the knife just slightly trims the fabric edge.
- ◆ Sew.
- ◆ Press seam allowance to one side.

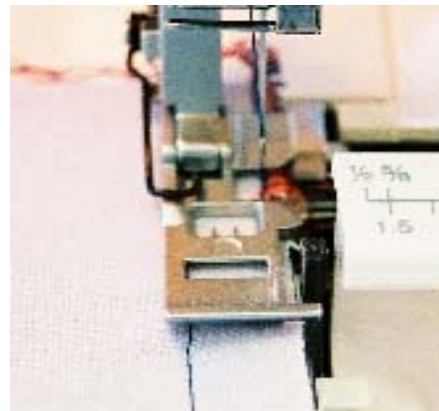

## Two-Thread Overedge (Wide)

The Two-Thread Overedge (wide) is a good choice when sewing linens and wools. The Two-Thread Overedge (wide) has the same set up as the Two-Thread Overedge (narrow) Stitch. The only exception is the Right Overedge Needle is now unthreaded and removed and the Left Overedge Needle is threaded. By using the left needle the stitch becomes wider.



## Set up:

### Needle:

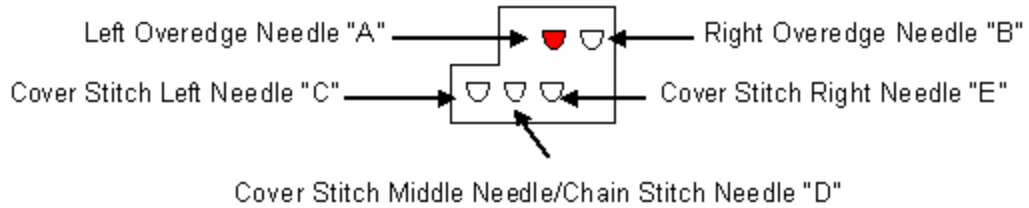

Set at:

<b>ATD:</b> Auto Tension Dial	"E"
Left Cover Stitch Needle "C" (Orange)	Unthreaded and Remove Needle
Middle Cover Stitch Needle "D" (Blue)	Unthreaded and Remove Needle
Right Cover Stitch Needle "E" (Green)	Unthreaded and Remove Needle
Overedge Left Needle "A" (Orange)	Threaded
Overedge Right Needle "B" (Blue)	Unthreaded and Remove Needle
Upper Looper (Green)	Engage Looper and Not Threaded
Spreader	Engaged
Lower Looper (Red)	Threaded
Chain Stitch Looper (Brown)	Not Threaded
Upper Knife	Engaged
Seam Guide Plate	Not Installed
Seam Width Dial	"N"
Stitch Length Dial	"2"
Presser Foot Pressure	"N"
Differential Feed Dial	"N"
Stitch Finger	"N"

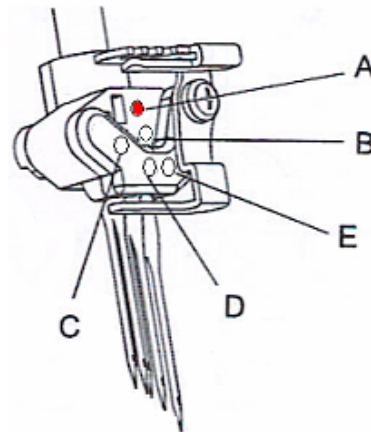



◆ Thread Left Overedge needle with regular thread.

1. Raise the Presser Foot to release the tension disks. Thread the left needle as illustrated 1-9.

2. Pass thread from back to the front through the thread guide ①.

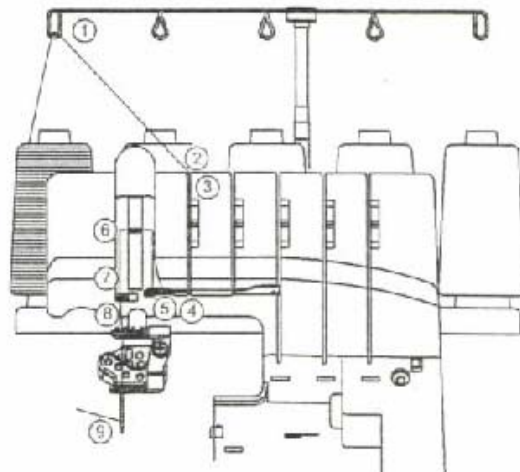
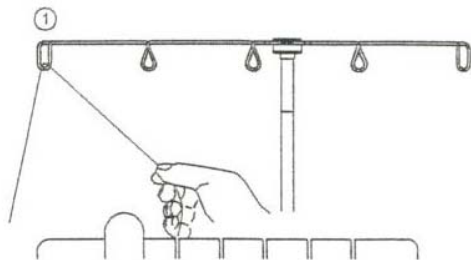

3. Thread the top cover thread guide by pulling the thread towards the left until it slips under the guide. Then pull the thread along the right side of the button as illustrated.

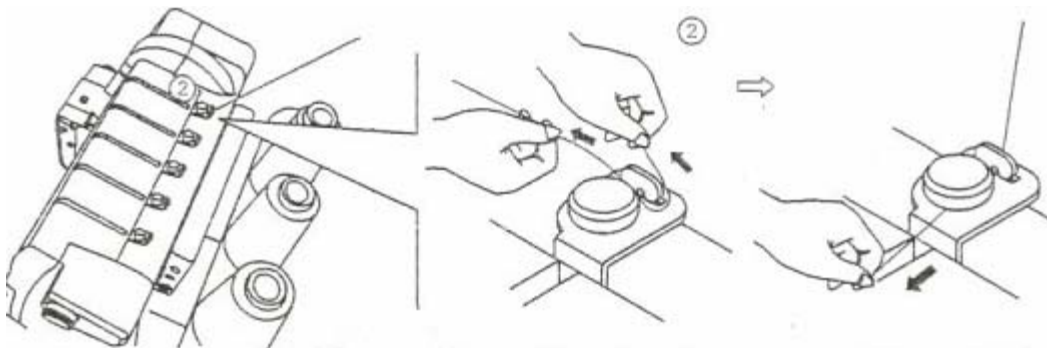

4. While holding the thread firmly, pull the thread between the tension disks.

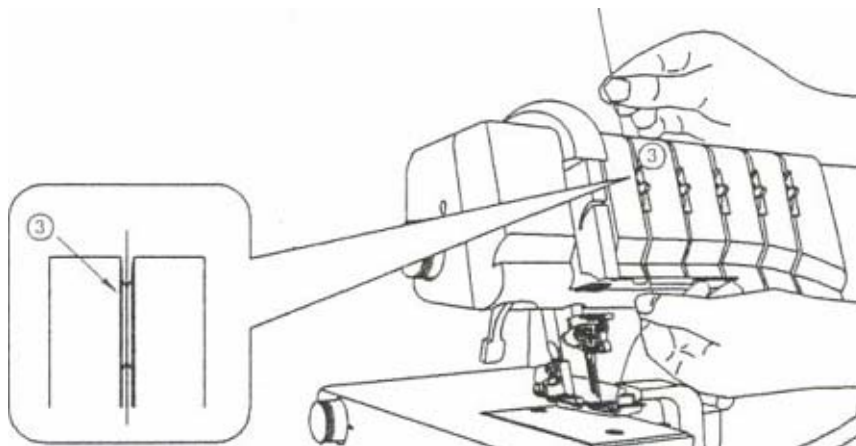

5. Continue to thread points 4-8. Slip the thread into the middle slot of the thread guide ⑤. Go over the take up lever ⑥. Continue by slipping the thread into the middle slot of the thread guides ⑦ and ⑧.
6. Before threading the eye of the needle, make sure the thread is behind the thread guide located on the bottom of the needle clamp.

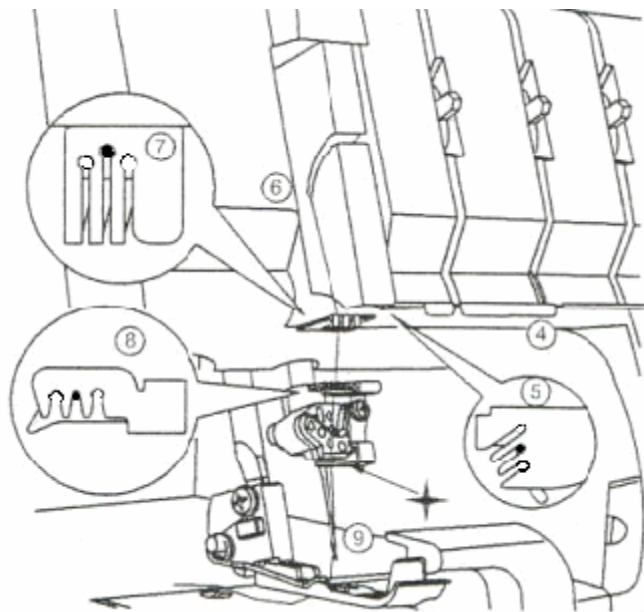

7. Thread the eye of the Left Overedge Needle ⑨.

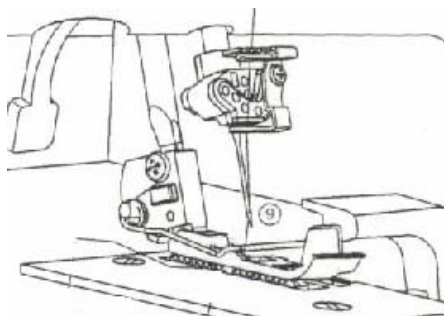

8. Draw about 4 inches of the thread through the needle eye towards the back of the machine.
9. Place the thread to the back, under the Presser Foot. Lower foot and sew.

## Try It:

- ◆ Align one piece of medium weight fabric so that the knife just slightly trims the fabric edge.
- ◆ Sew.
- ◆ Align a second piece of medium weight fabric so that the knife just slightly trims the fabric edge.
- ◆ Sew.
- ◆ Place the two fabrics, right sides together.
- ◆ Using a conventional sewing machine, sew a straight stitch with a  $\frac{5}{8}$  inch seam.
- ◆ Press the seam open.

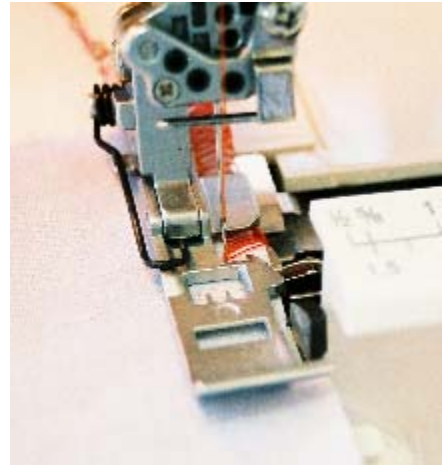

## Three-Thread Overlock (Narrow)

The Three-Thread Overlock Stitch is the most commonly used stitch because of its versatility. It provides a wonderful professional seam finish to woven fabrics. It is beneficial in preventing loosely woven fabrics from unraveling. In addition, the Three-Thread Overlock Stitch offers unlimited decorative capabilities. It is recommended for finishing seams but not reinforcing the seam. Use the conventional sewing machine's straight stitch to reinforce the seam. The stitch uses one overedge needles and both the upper looper and lower looper. There are 2 different ways to set up for a Three-Thread Overlock stitch. For a more narrow stitch (4.0) select the Right Overedge needle; for a wider stitch (6.0) the Left Overedge needle is used.



Right Overedge Needle Thread

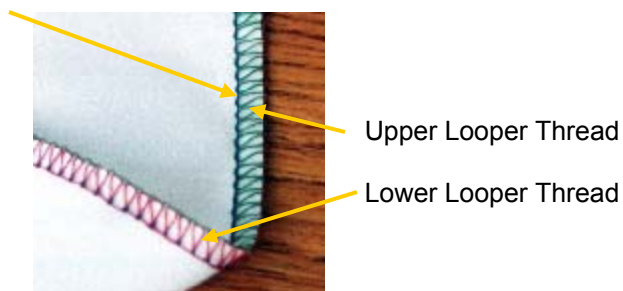

## Set up:

### Needle:

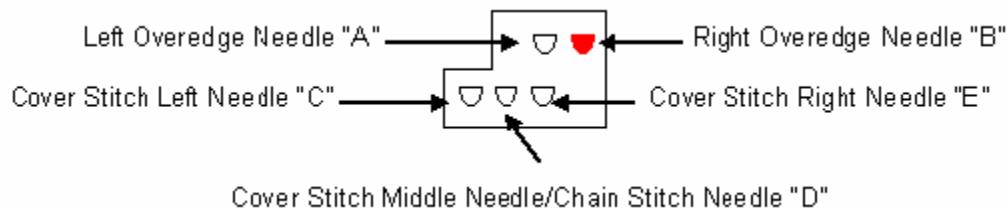

### Set-up:

<b>ATD:</b> Auto Tension Dial	"A"
Left Cover Stitch Needle "C"	Unthreaded and Remove Needle
Middle Cover Stitch Needle "D"	Unthreaded and Remove Needle
Right Cover Stitch Needle "E"	Unthreaded and Remove Needle
Overedge Left Needle "A"	Unthreaded and Remove Needle
Overedge Right Needle "B" (Blue)	Threaded
Upper Looper (Green)	Looper Engaged and Threaded
Spreader	Not Used
Lower Looper (Red)	Threaded
Chain Stitch Looper (Brown)	Unthreaded
Upper Knife	Engaged
Seam Guide Plate	Not Installed, use Knife Cover Plate
Seam Width Dial	"N"
Stitch Length Dial	"2"
Presser Foot Pressure	"N"
Differential Feed Dial	"N"
Stitch Finger	"N"

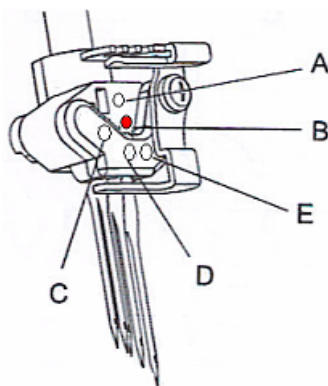

The Three-Thread Overlock makes a great edge finish to a garment's facing.



- ◆ Turn Auto Tension Dial to “A”.

- ◆ Turn Stitch Length Dial to “2”.



- ◆ Engage Upper Knife. The knife will not trim the fabric when it is disengaged.
  1. Open Looper Cover.
  2. Pull the movable knife holder (silver screw) to the right as far as it will go.
  3. Turn the holder clockwise until the knife clicks into a lock position.

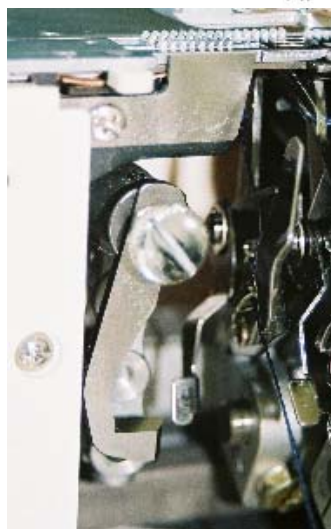
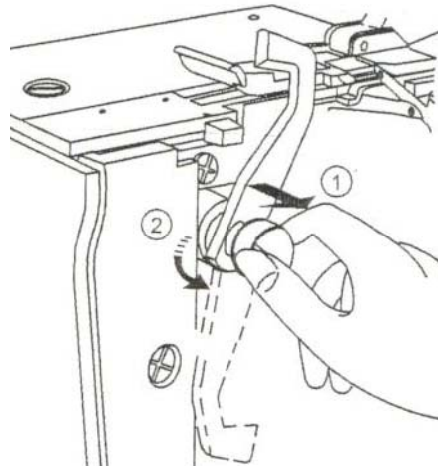

Upper Knife Disengaged



Upper Knife Engaged

- ◆ Turn Presser Foot Pressure Dial to “N”.



- ◆ Turn Differential Feed Dial to “N”.



- ◆ Turn Seam Width Dial to “N”.

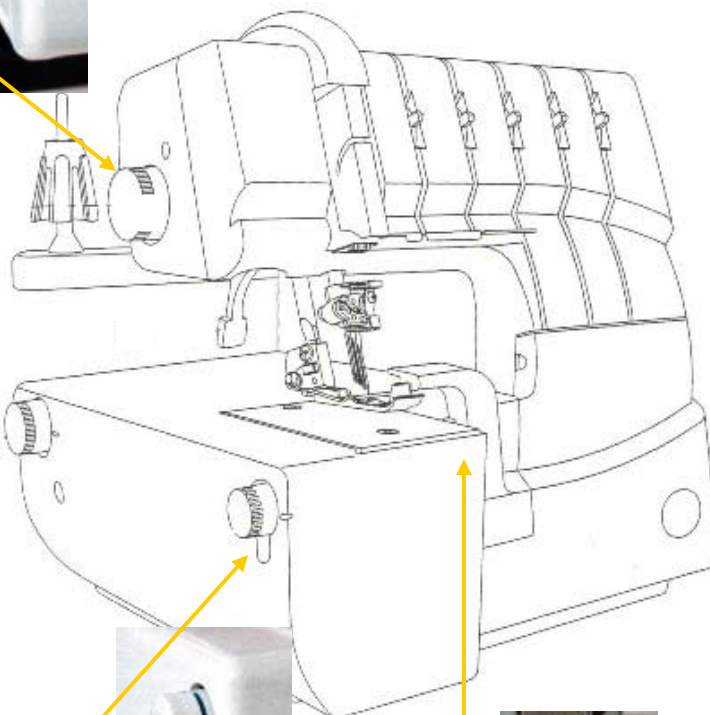

- ◆ Set Stitch Finger to “N”.



# SINGER®

- ◆ Install the Knife Cover.

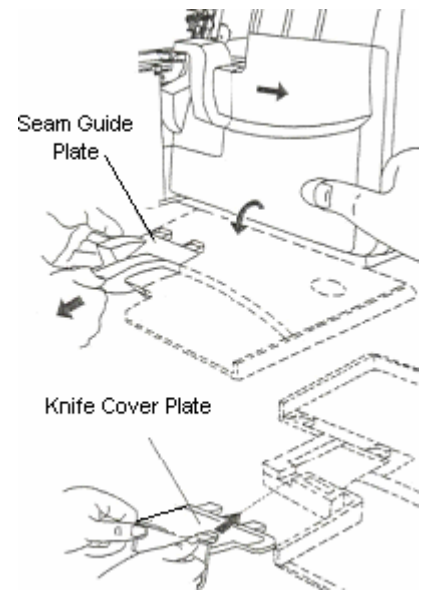

- ◆ Engage Upper Looper. Engaging the Upper Looper causes the looper move when sewing. Even though the Upper Looper is not threaded it needs to be engaged.
  1. Push the clutch button to the left and down to engage.
  2. Turn handwheel.

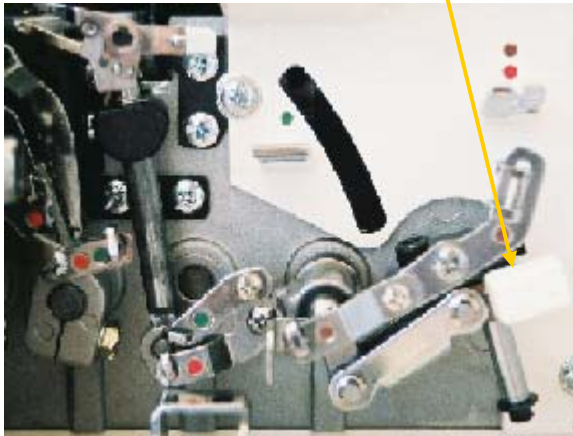

Upper Looper Disengaged

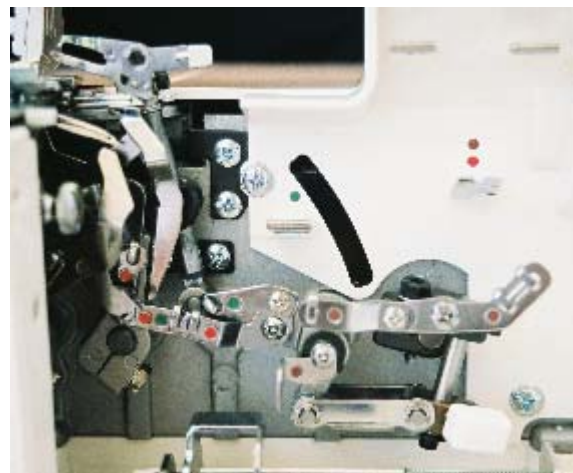
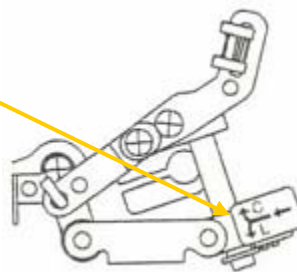

Upper Looper Engaged

- ◆ Disengage Spreader. The Upper Looter has a hole for the thread on the top of the looper. If the stitch requires that the looper be engaged but not threaded, then the Spreader is used. The Spreader simply plugs-in (or closes) the looper's hole. The Spreader is disengaged when the Upper Looter is engaged/operative and threaded. The Spreader is used with a stitch that requires only one looper thread. With the help of the Spreader, the single looper thread wraps around the fabric's edge.

1. Lower the white handle on the Spreader to open the eye of the Upper Looter.

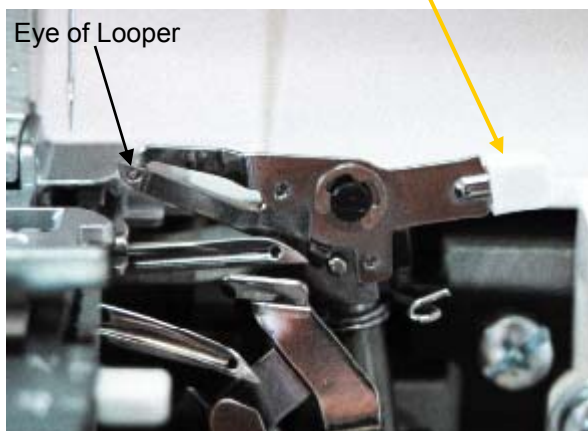

Spreader Engaged



Spreader Disengaged

- ◆ Thread Upper Looter with regular overlock thread.

1. Raise the Presser Foot to release the tension disks. Thread the Lower Looter as illustrated 1-9.

2. Pass thread from back to the front through the thread guide.

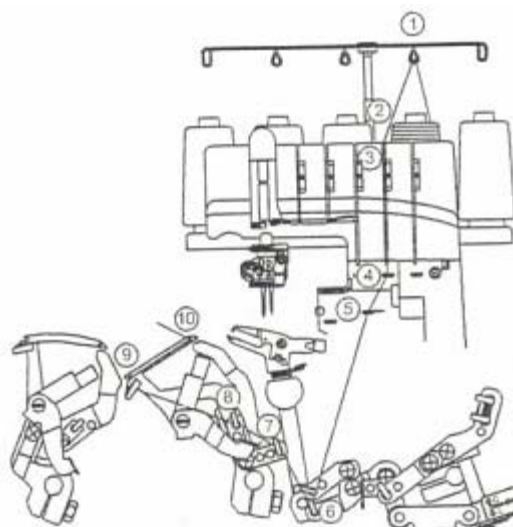
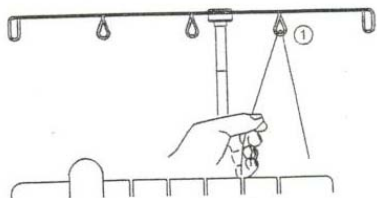

3. Thread the top cover thread guide by pulling the thread towards the left until it slips under the guide. Then pull the thread along the right side of the button as illustrated.

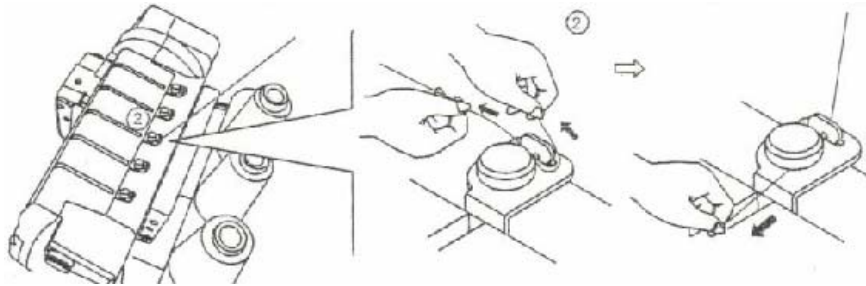

4. While holding the thread, firmly pull the thread between the tension disks.

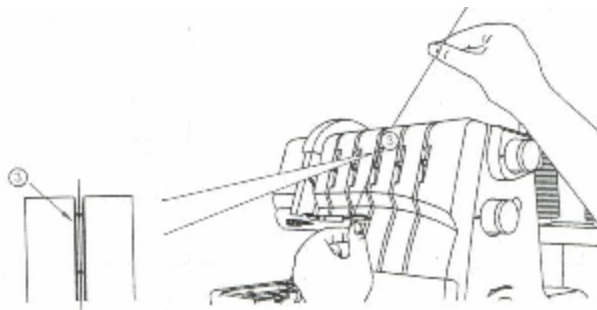

5. Turn the handwheel toward you until the lower looper extends 5-10mm (approximately 1/2") from the needle plate edge.

6. Thread the looper area of the machine following the green color coded thread guides 4-9.

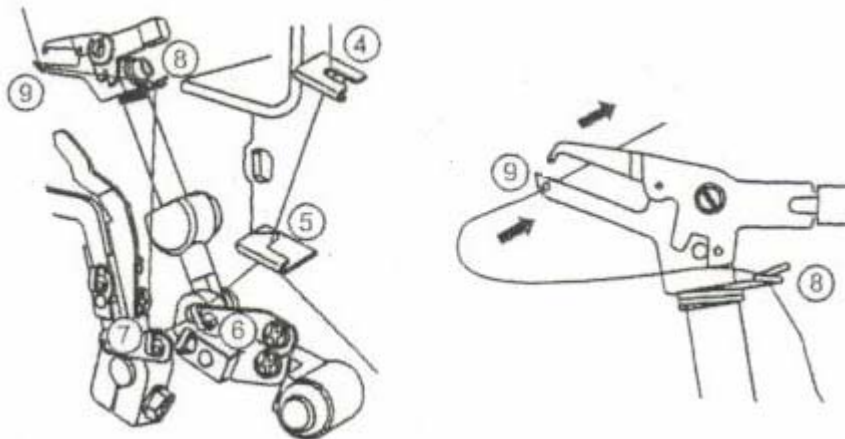

7. Thread the hole in the Upper Looter from front to back ⑨. Pull about 4 inches of thread through the looper and place to the back of the throat plate.

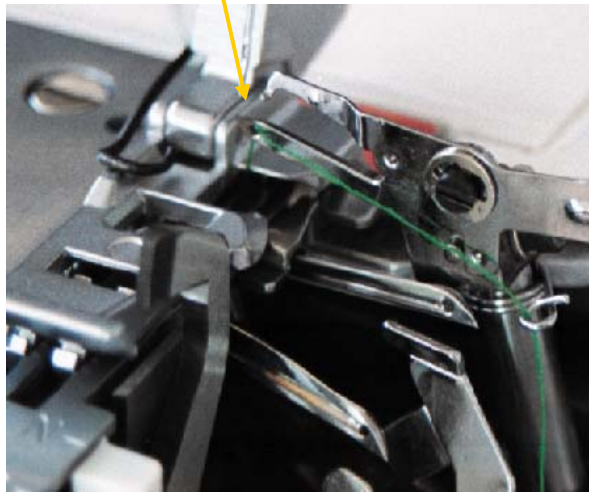

◆ Thread Lower Looter with regular overlock thread.

1. Raise the Presser Foot to release the tension disks. Thread the Lower Looter as indicated 1-10.
2. Pass thread from back to the front through the thread guide ①.

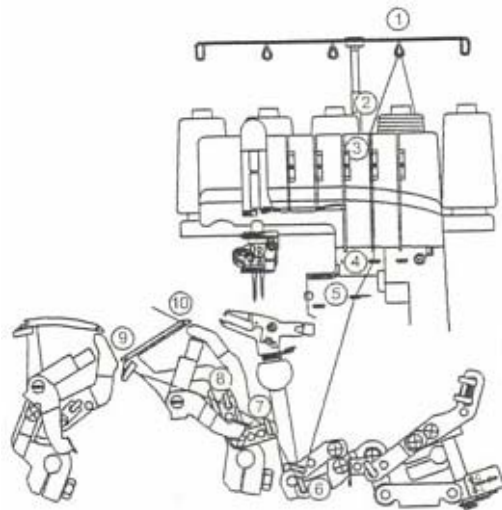
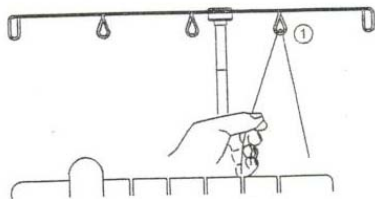

3. Thread the top cover thread guide by pulling the thread towards the left until it slips under the guide. Then pull the thread along the right side of the button as illustrated.

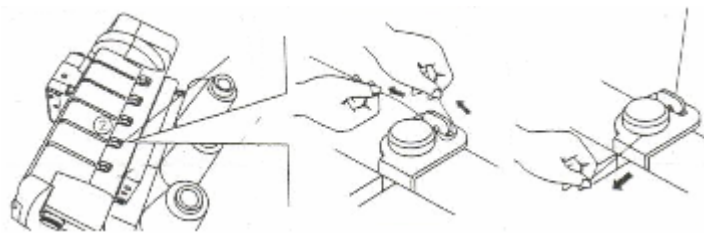

4. While holding the thread, firmly pull the thread between the tension disks.

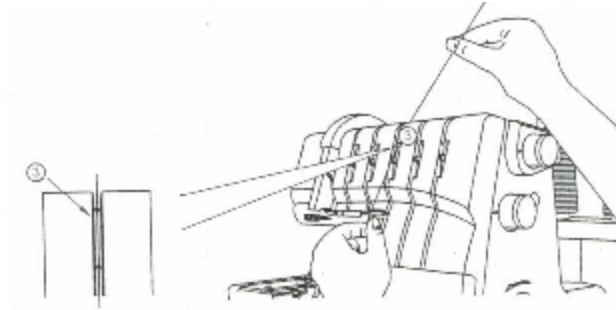

5. Turn the handwheel toward you until the lower looper extends 5-10mm (approximately 1/2") from the needle plate edge.
6. Thread the looper area of the machine following the red color coded thread guides 4-10.

7. Place the thread slightly from left and to the right of threading guide ④.

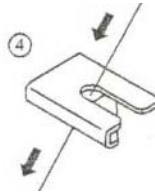

8. Place the thread slightly from the front and to the back of threading guide ⑤.

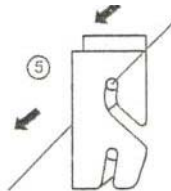

9. Place the thread through ⑥, ⑦ and ⑧.

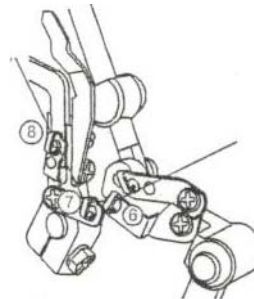

10. Thread the looper eye (A) from front to back. Pull about 4 inches of thread. Position thread into V cutout (B) on threader. Firmly hold thread tail with left hand and pull Threader Lever (C) up into place (D).

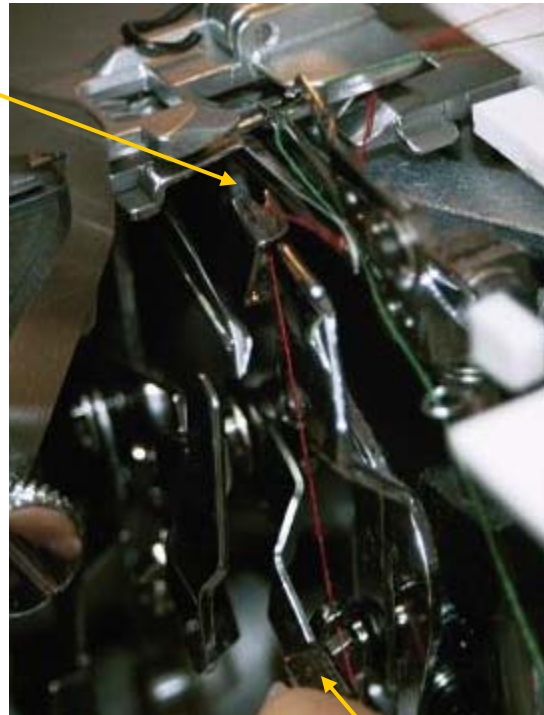
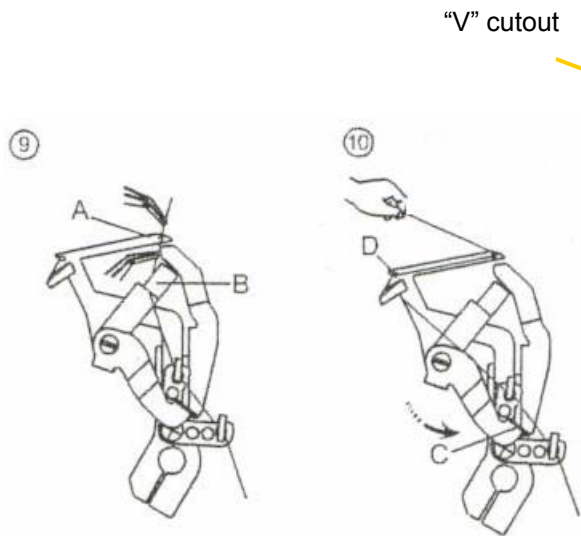

Threader Lever



NOTE: Make sure the Upper Looper thread is behind the Lower Looper thread.

◆ Thread Right Overedge needle with regular thread.

1. Raise the Presser Foot to release the tension disks. Thread the right needle as indicated 1-9.

2. Pass thread from back to the front through the thread guide ①.

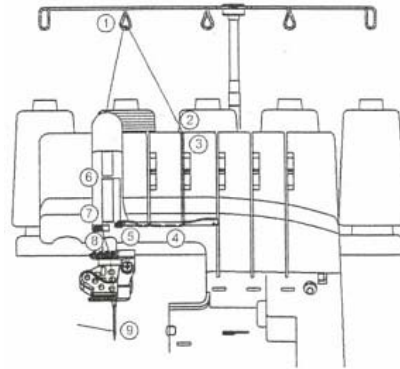
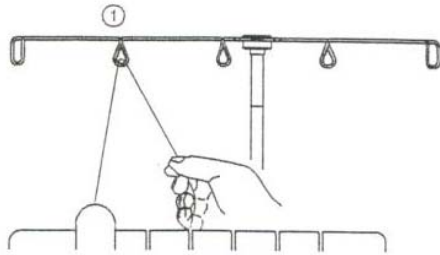

3. Thread the top cover thread guide by pulling the thread towards the left until it slips under the guide. Then pull the thread along the right side of the button as illustrated.

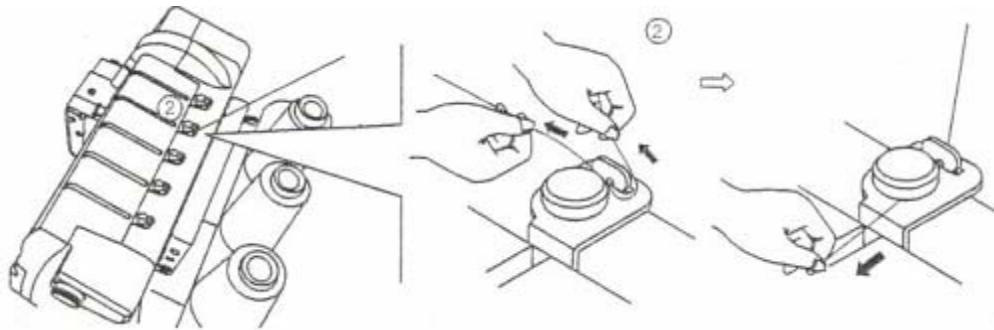

4. While holding the thread firmly, pull the thread between the tension disks.

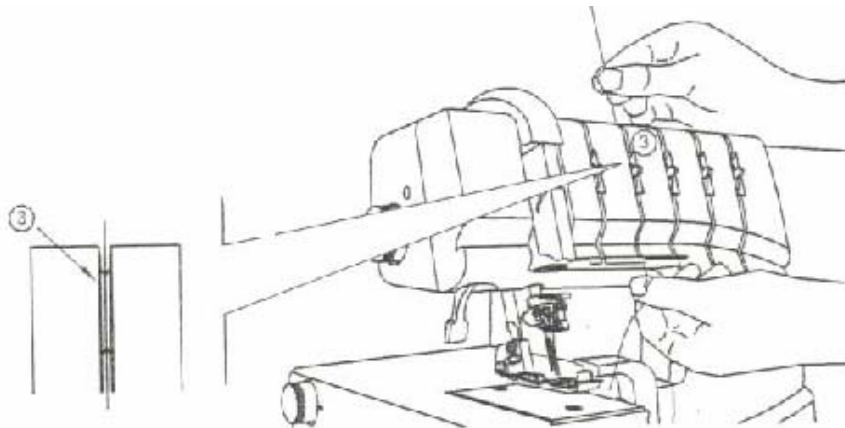

# SINGER®

5. Continue to thread points 4-8. Slip the thread into the rear slot of the thread guide ⑤. Go over the take up lever ⑥. Continue by slipping the thread into the right slot of the thread guides ⑦ and ⑧.
8. Before threading the eye of the needle, make sure the thread is behind the thread guide located on the bottom of the needle clamp.

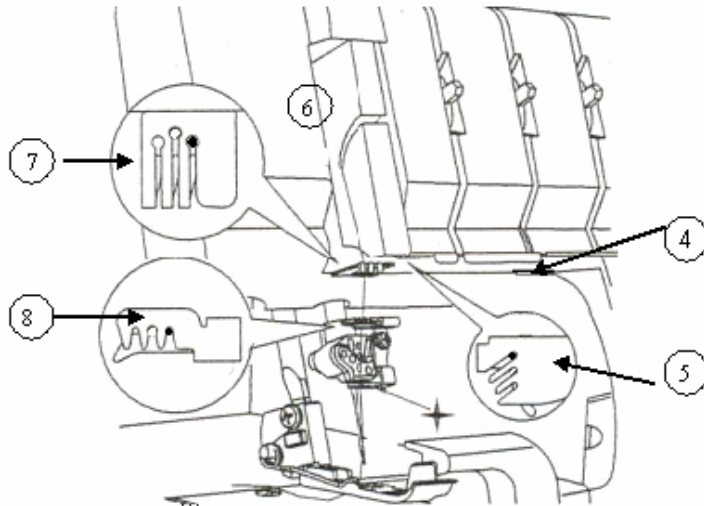

9. Draw about 4 inches of the thread through the needle eye towards the back of the machine.
10. Place the thread to the back, under the Presser Foot.

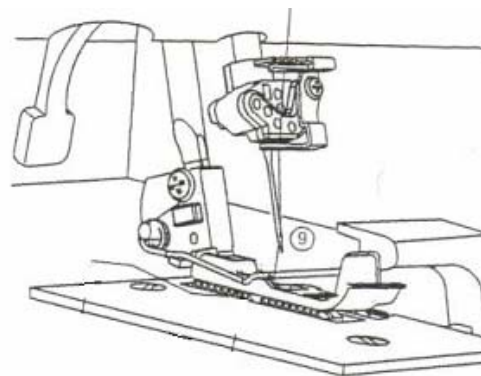
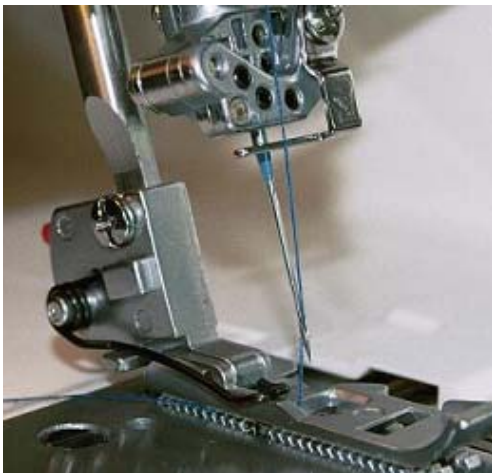



# SINGER®

## Try It:

- ◆ Align one piece of medium weight fabric so that the knife just slightly trims the fabric edge.
- ◆ Sew.
- ◆ Align a second piece of medium weight fabric so that the knife just slightly trims the fabric edge.
- ◆ Place the two fabrics, right sides together.
- ◆ Using a conventional sewing machine, sew a straight stitch with a  $\frac{5}{8}$  inch seam.
- ◆ Press the seam open.



## Three-Thread Overlock (Wide)

The Three-Thread Overedge (wide) has the same set up as the Three-Thread Overedge (narrow) Stitch. The only exceptions are the Right Overedge Needle is now unthreaded and removed and the Left Overedge Needle is threaded. By using the left needle the stitch becomes wider. The other exception is the Auto Tension Dial is turned to "B".

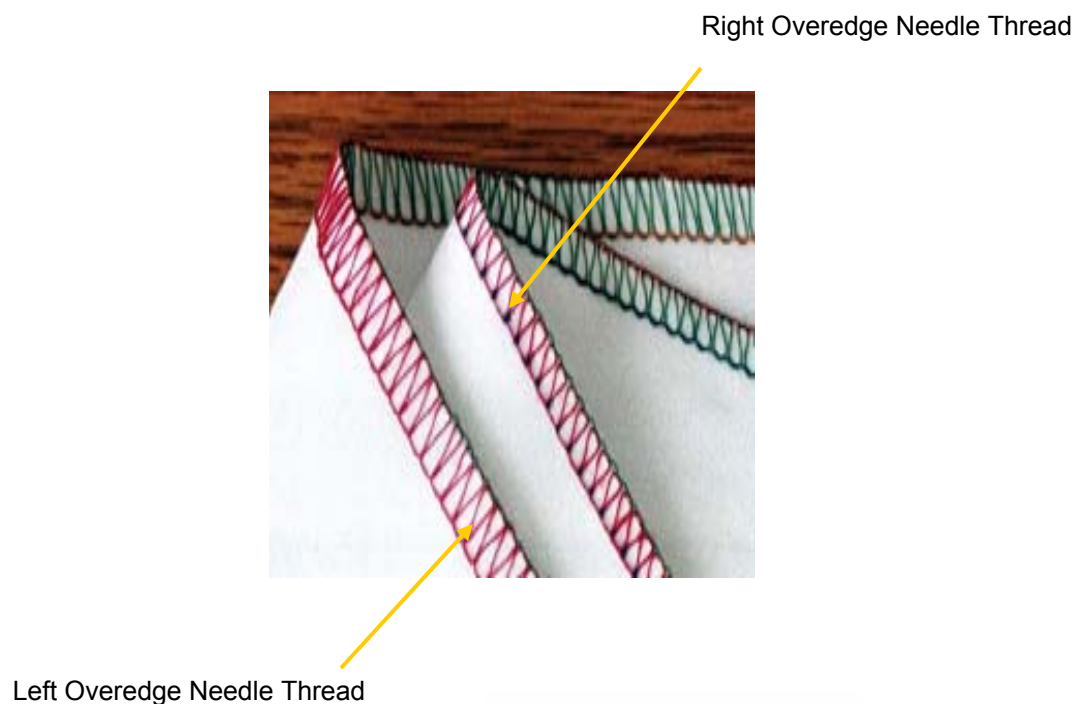

## Set up:

### Needle:

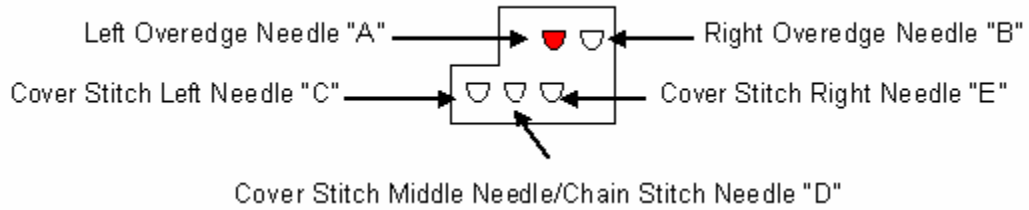

### Set-up:

ATD: Auto Tension Dial	"B"
Left Cover Stitch Needle "C"	Unthreaded and Remove Needle
Middle Cover Stitch Needle "D"	Unthreaded and Remove Needle
Right Cover Stitch Needle "E"	Unthreaded and Remove Needle
Overedge Left Needle "A" (Orange)	Threaded
Overedge Right Needle "B"	Unthreaded and Remove Needle
Upper Loper (Green)	Looper Engaged and Threaded
Spreader	Disengaged
Lower Loper (Red)	Threaded
Chain Stitch Loper (Brown)	Unthreaded
Upper Knife	Engaged
Seam Guide Plate	Not Installed, use Knife Plate Cover
Seam Width Dial	"N"
Stitch Length Dial	"2"
Presser Foot Pressure	"N"
Differential Feed Dial	"N"
Stitch Finger	"N"

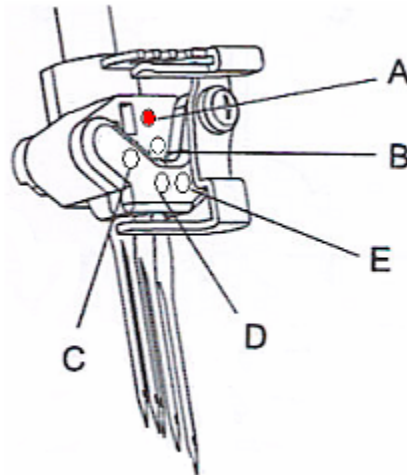

◆ Thread Left Overedge needle with regular thread.

1. Raise the Presser Foot to release the tension disks. Thread the left needle as illustrated 1-9.

2. Pass thread from back to the front through the thread guide.

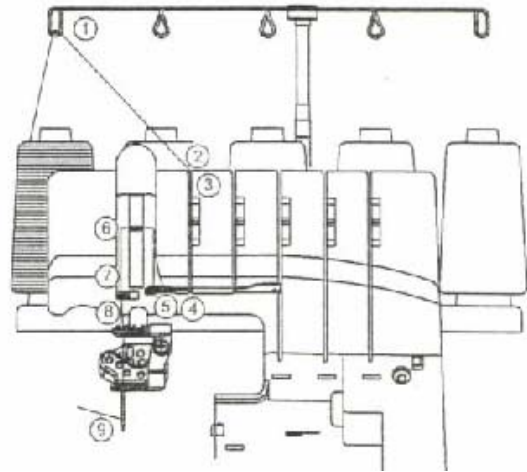
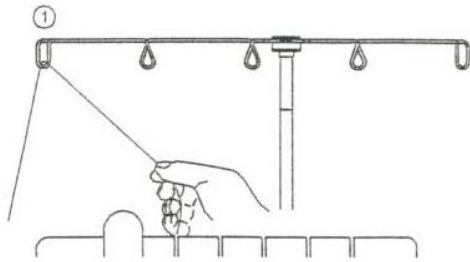

3. Thread the top cover thread guide by pulling the thread towards the left until it slips under the guide. Then pull the thread along the right side of the button as illustrated.

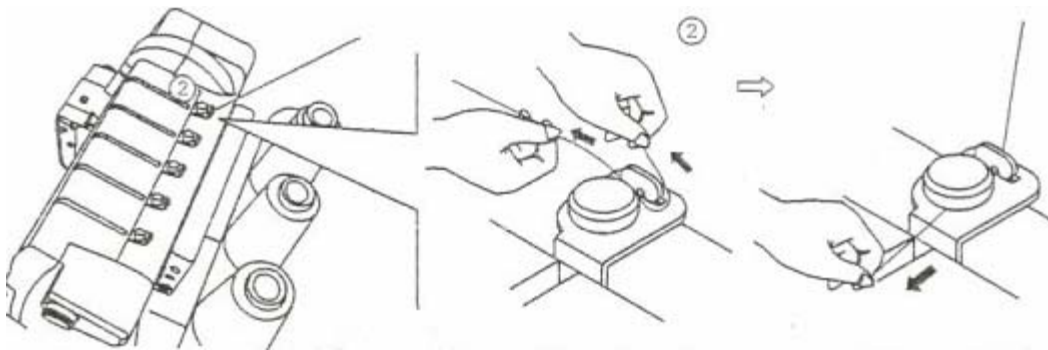

4. While holding the thread firmly, pull the thread between the tension disks.

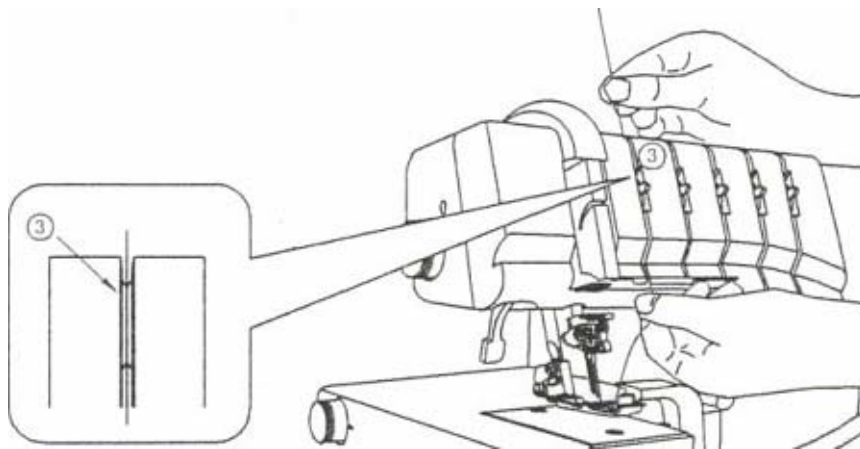

5. Continue to thread points 4-8. Slip the thread into the middle slot of the thread guide ⑤. Go over the take up lever ⑥. Continue by slipping the thread into the middle slot of the thread guides ⑦ and ⑧.
6. Before threading the eye of the needle, make sure the thread is behind the thread guide located on the bottom of the needle clamp.

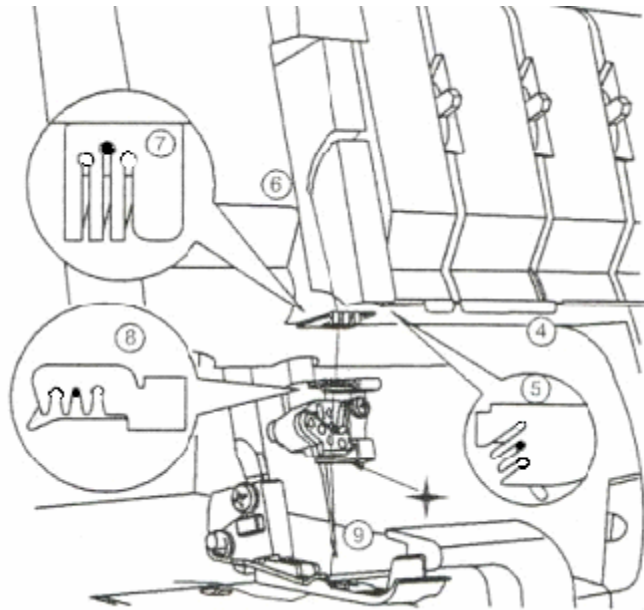

7. Thread the eye of the left needle ⑨.

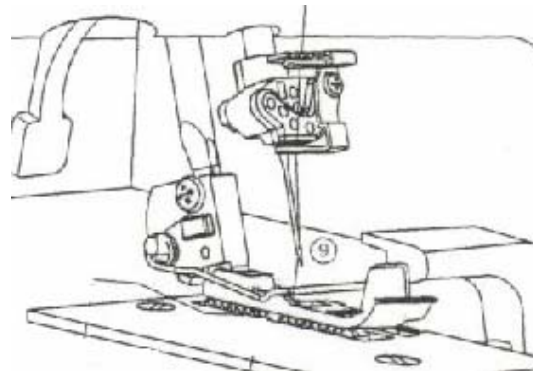
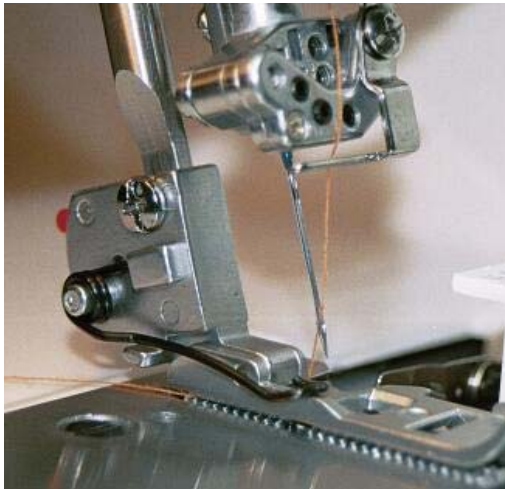

8. Draw about 4 inches of the thread through the needle eye towards the back of the machine.
9. Place the thread to the back, under the Presser Foot.

# SINGER®

- ◆ Turn Auto Tension Dial to “B”.

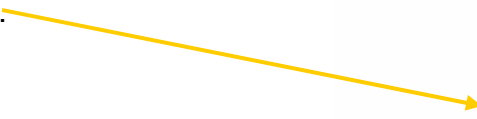

- ◆ Turn Stitch Length Dial to “2”.

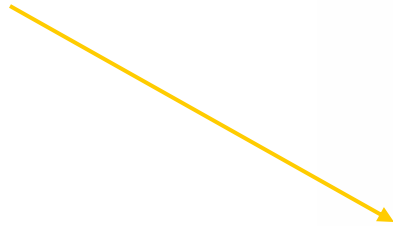

## Try It:

- ◆ Align one piece of medium weight fabric so that the knife just slightly trims the fabric edge.
- ◆ Sew.



## Three-Thread Overlock (Wide—Decorative Thread)

Using decorative threads can duplicate the look of fine braids and bindings often found only in ready-to-wear. It is easy to embellish sewing projects with decorative thread. Threads such as texturized nylon thread, crochet thread, pearl cotton, yarn and more easily slide through the eye of the looper. Select soft, flexible threads for best results.



## Set up:

### Needle:

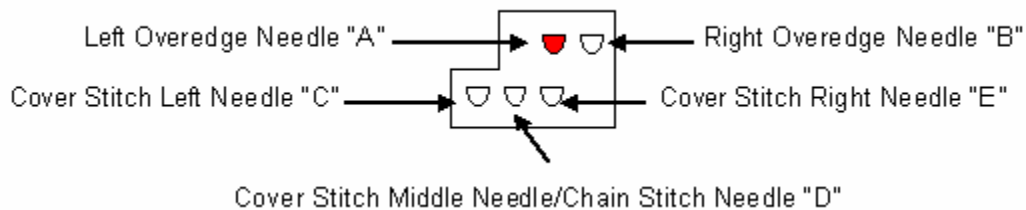

### Set-up:

<b>ATD:</b> Auto Tension Dial	"B"
Left Cover Stitch Needle "C"	Unthreaded and Remove Needle
Middle Cover Stitch Needle "D"	Unthreaded and Remove Needle
Right Cover Stitch Needle "E"	Unthreaded and Remove Needle
Overedge Left Needle "A" (Orange)	Threaded
Overedge Right Needle "B"	Unthreaded and Remove Needle
Upper Looper (Green)	Looper Engaged and Threaded
Spreader	Disengaged
Lower Looper (Red)	Threaded
Chain Stitch Looper (Brown)	Unthreaded
Upper Knife	Engaged
Seam Guide Plate	Not Installed, use Knife Plate Cover
Seam Width Dial	"N"
Stitch Length Dial	"2"
Presser Foot Pressure	"N"
Differential Feed Dial	"N"
Stitch Finger	"N"

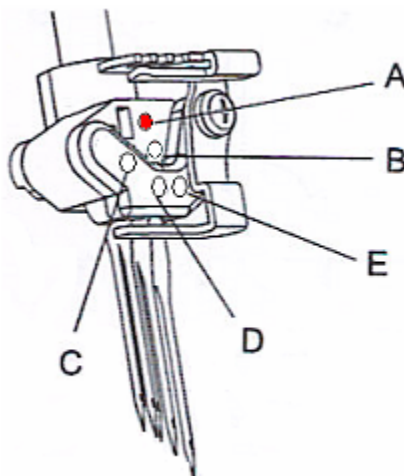



◆ Thread Upper Looper with decorative thread.

1. Raise the Presser Foot to release the tension disks. Thread the Lower Looper as illustrated 1-9.

2. Pass thread from back to the front through the thread guide.

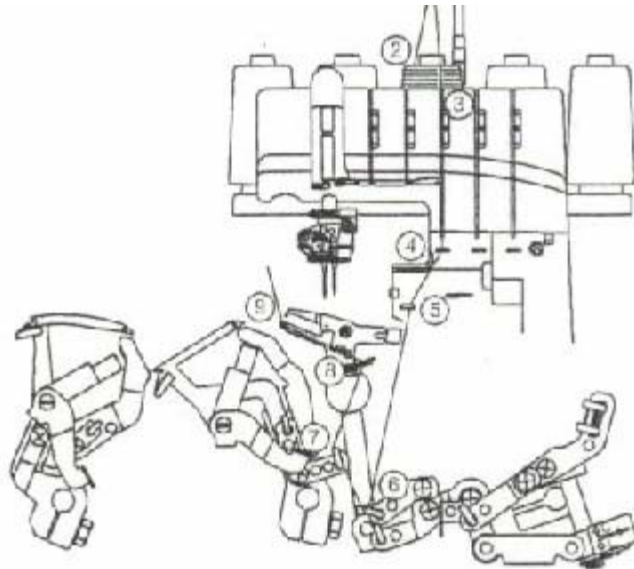
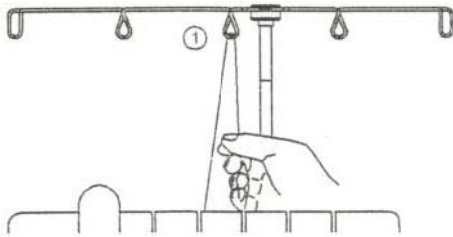

3. Thread the top cover thread guide by pulling the thread towards the left until it slips under the guide. Then pull the thread along the right side of the button as illustrated.

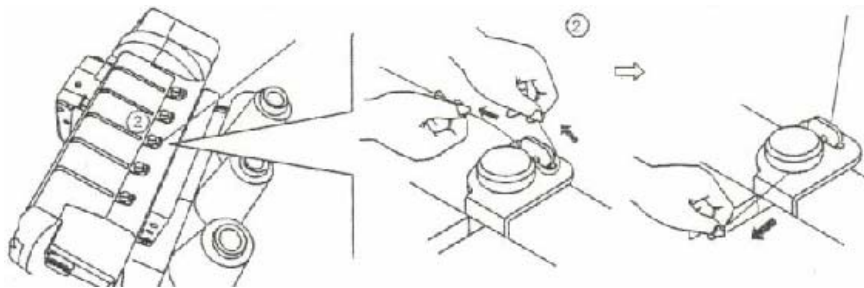

4. While holding the thread firmly, pull the thread between the tension disks.

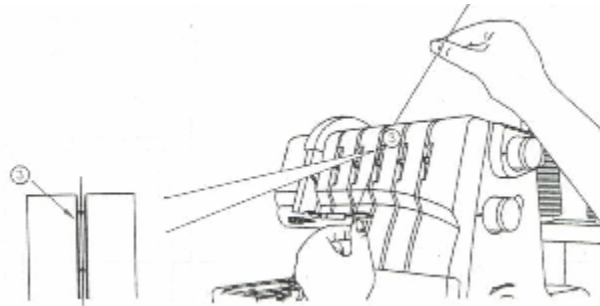

5. Turn the handwheel toward you until the lower looper extends 5-10mm (approximately ½ inch) from the needle plate edge.
6. Thread the looper area of the machine following the green color coded thread guides 4-9.

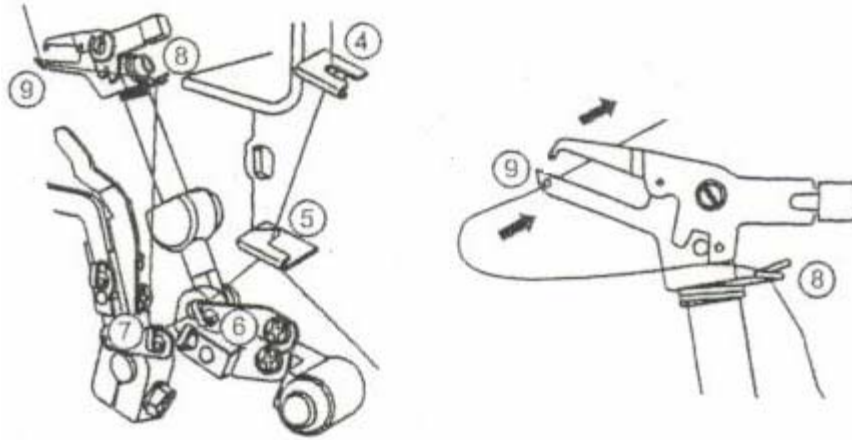

7. Thread the hole in the Upper Looper from front to back ⑨. Pull about 4 inches of thread through the looper and place to the back of the throat plate.

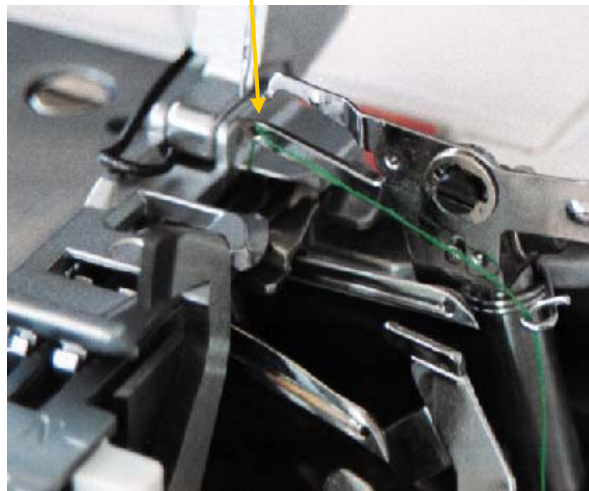

◆ Thread Lower Looper with decorative overlock thread.

1. Raise the Presser Foot to release the tension disks. Thread the Lower Looper as illustrated 1-10.
2. Pass thread from back to the front through the thread guide ①.

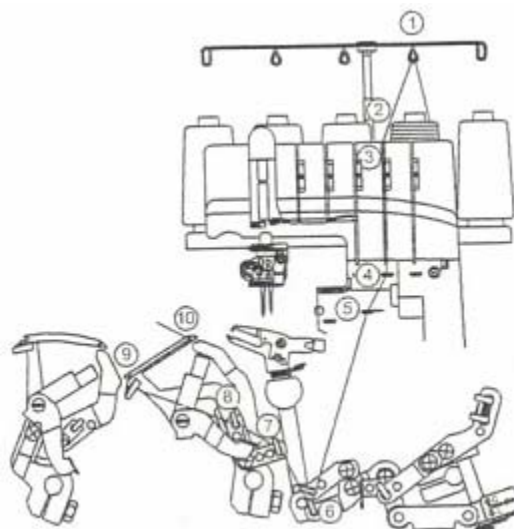
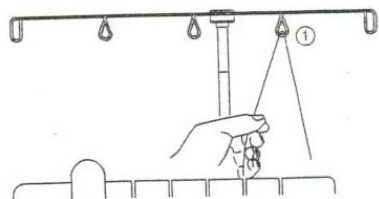

3. Thread the top cover thread guide by pulling the thread towards the left until it slips under the guide. Then pull the thread along the right side of the button as illustrated.

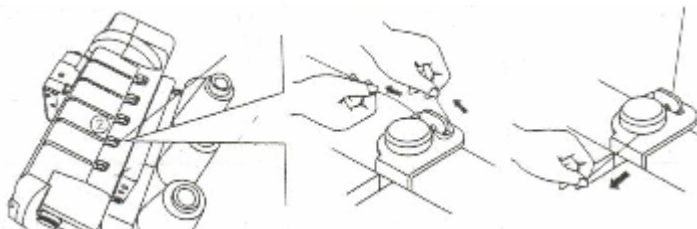

4. While holding the thread, firmly pull the thread between the tension disks.

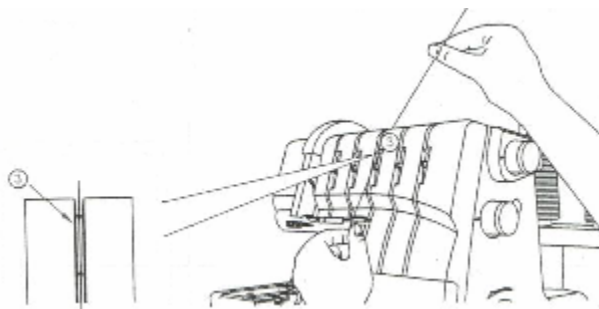

5. Turn the handwheel toward you until the lower looper extends 5-10mm (approximately ½ inch) from the needle plate edge.

# SINGER®

6. Thread the looper area of the machine following the red color coded thread guides 4-10.

7. Place the thread slightly from left and to the right of threading guide ④.

8. Place the thread slightly from the front and to the back of threading guide ⑤.

9. Place the thread through ⑥, ⑦, and ⑧.

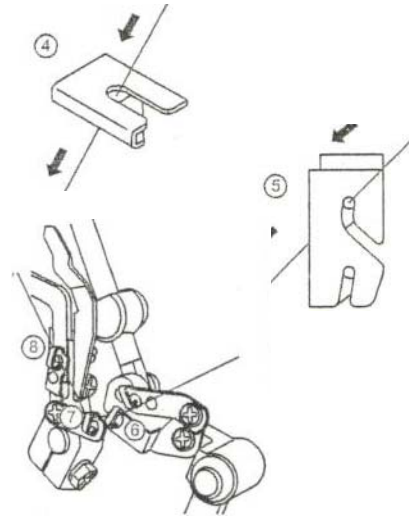

10. Thread the looper eye (A) from front to back. Pull about 4 inches of thread. Position thread into V cutout (B) on threader. Firmly hold thread tail with left hand and pull Threader lever (C) up into place (D).

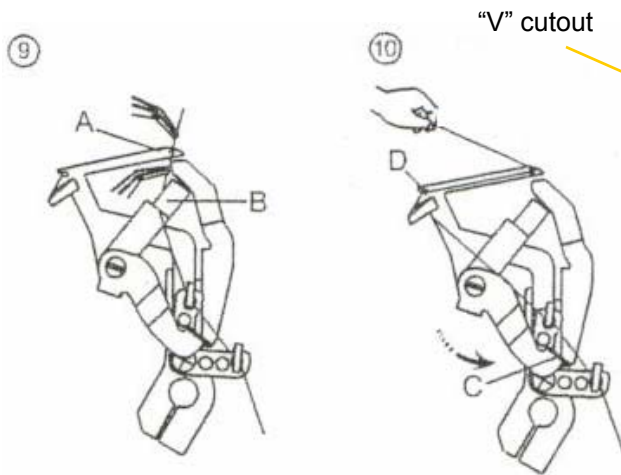

11. Thread eye of looper.

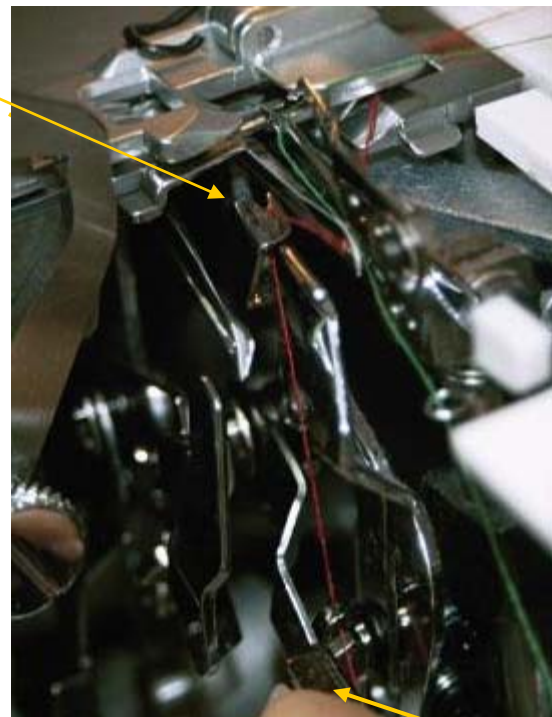

Threader Lever

NOTE: Make sure the Upper Looper thread is behind the Lower Looper thread.

◆ Thread Overedge Left needle with regular thread.

1. Raise the Presser Foot to release the tension disks. Thread the left needle as illustrated 1-9.

2. Pass thread from back to the front through the thread guide ①.

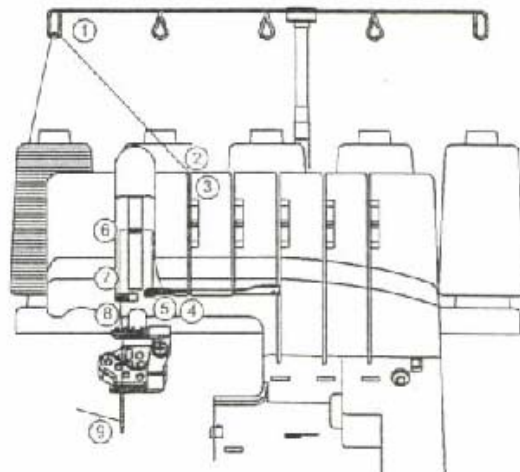
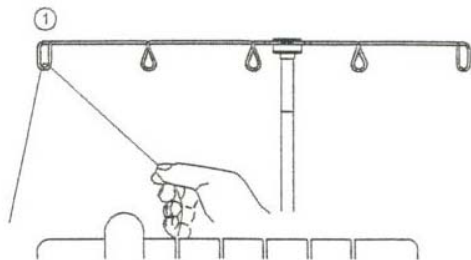

3. Thread the top cover thread guide by pulling the thread towards the left until it slips under the guide. Then pull the thread along the right side of the button as illustrated.

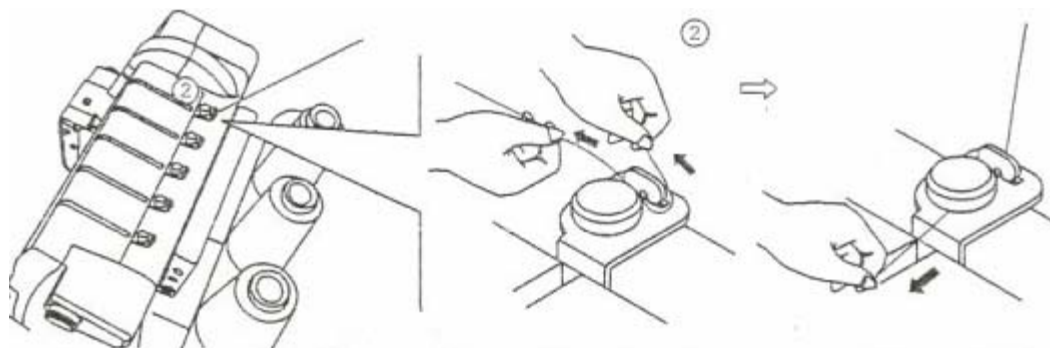

4. While holding the thread firmly, pull the thread between the tension disks.

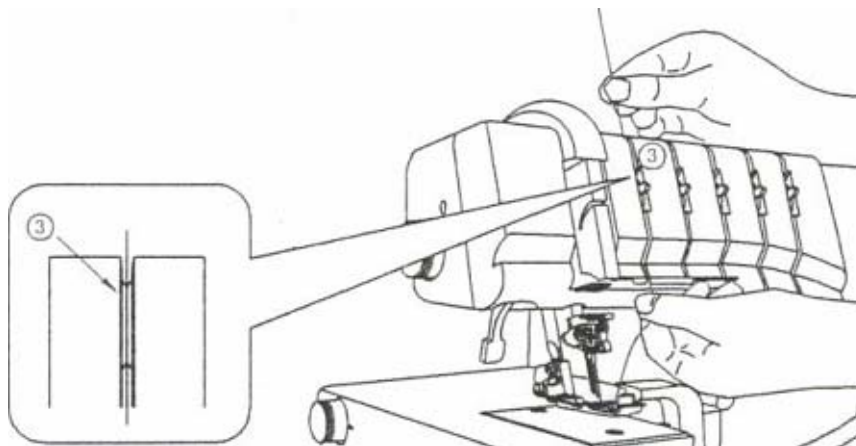

5. Continue to thread points 4-8. Slip the thread into the middle slot of the thread guide ⑤. Go over the take up lever ⑥. Continue by slipping the thread into the middle slot of the thread guides ⑦ and ⑧.
6. Before threading the eye of the needle, make sure the thread is behind the thread guide located on the bottom of the needle clamp.

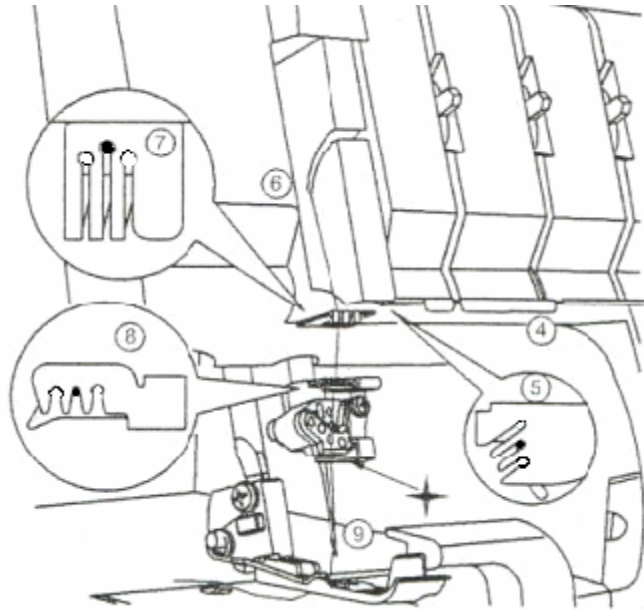

7. Thread the eye of the Left Overedge Needle ⑨.

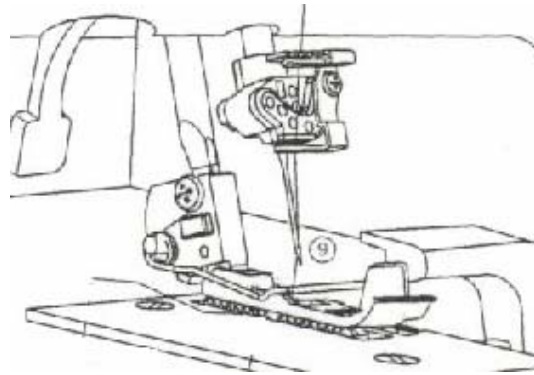
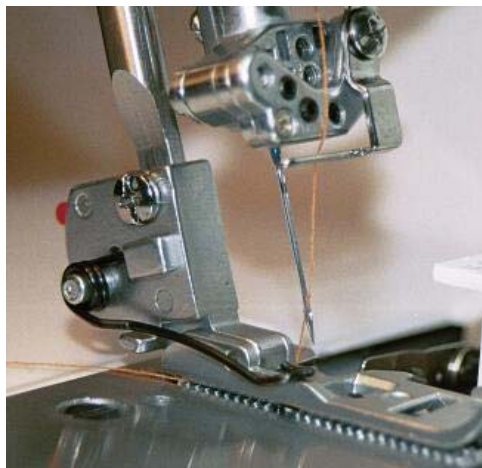

8. Draw about 4 inches of the thread through the needle eye towards the back of the machine.
9. Place the thread to the back, under the Presser Foot. Lower foot and sew.

# SINGER®

## Try It:

- ◆ Align double-sided quilted fabric so that the knife just slightly trims the fabric edge.
- ◆ Sew.



## Three-Thread Flatlock (Narrow)

The Flatlock Stitch is used decoratively to achieve the look of applied trim on a garment, craft or home decorator projects. Special decorative threads are used for a textured and dramatic embellishment effect. The Flatlock Stitch can also be used to serge non-bulky seams. The Flatlock Stitch is sewn with one needle and the upper and lower loopers. Both sides of the Flatlocking Stitch are considered decorative. The decorative loop effect is achieved when the Flatlock seams are stitched with the fabrics wrong sides together. The ladder stitch is achieved when the Flatlock seams are stitched with the fabrics right sides together. There are 2 different ways to set up for a Three-Thread Flatlock stitch. For a more narrow stitch (4.0) select the right overedge needle; for a wider stitch (6.0) the left overedge needle is used.





## Set up:

### Needle:

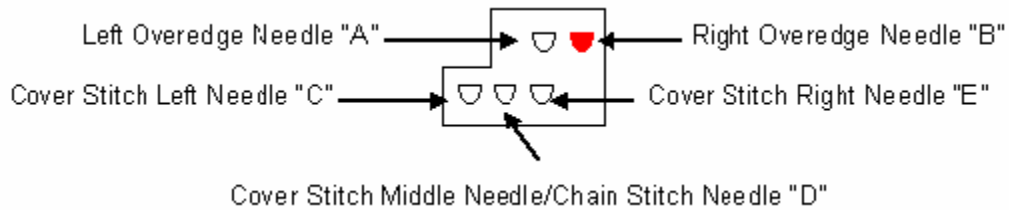

### Set Up:

<b>ATD:</b> Auto Tension Dial	"F"
Left Cover Stitch Needle "C"	Unthreaded and Remove Needle
Middle Cover Stitch Needle "D"	Unthreaded and Remove Needle
Right Cover Stitch Needle "E"	Unthreaded and Remove Needle
Overedge Left Needle "A"	Unthreaded and Remove Needle
Overedge Right Needle "B" (Blue)	Threaded
Upper Looper (Green)	Looper Engaged and Threaded
Spreader	Disengaged
Lower Looper (Red)	Threaded
Chain Stitch Looper (Brown)	Unthreaded
Upper Knife	Engaged
Seam Guide Plate	Not Installed, use Knife Cover Plate
Seam Width Dial	"N"
Stitch Length Dial	"2"
Presser Foot Pressure	"N"
Differential Feed Dial	"N"
Stitch Finger	"N"

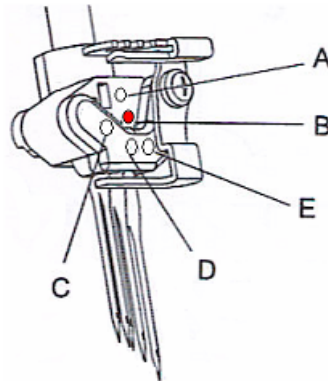



The Flatlock stitch, with fabric's right sides together, form a ladder stitch. A ribbon can then be woven by hand in and out of the stitches. The ladder stitch is ideal for joining laces together, as seen in heirloom sewing. Another idea for the ladder stitch is to use decorative thread through the needle to form a bold embellishment to projects.



**SINGER®**



- ◆ Turn Auto Tension Dial to “F”.

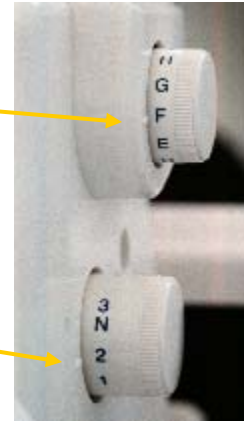

- ◆ Turn Stitch Length Dial to “2”.

- ◆ Engage Upper Knife. The knife will not trim the fabric when it is disengaged.
  1. Open Looper Cover.
  2. Pull the movable knife holder (silver screw) to the right as far as it will go.
  3. Turn the holder clockwise until the knife clicks into a lock position.

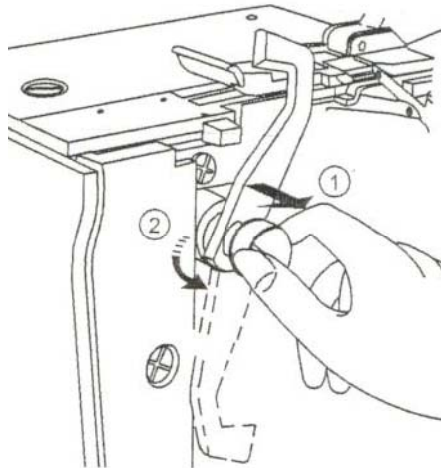

Upper Knife Disengaged



Upper Knife Engaged

- ◆ Turn Presser Foot Pressure to “N”.



- ◆ Turn Differential Feed Dial to “N”.



- ◆ Turn Seam Width Dial to “N”.

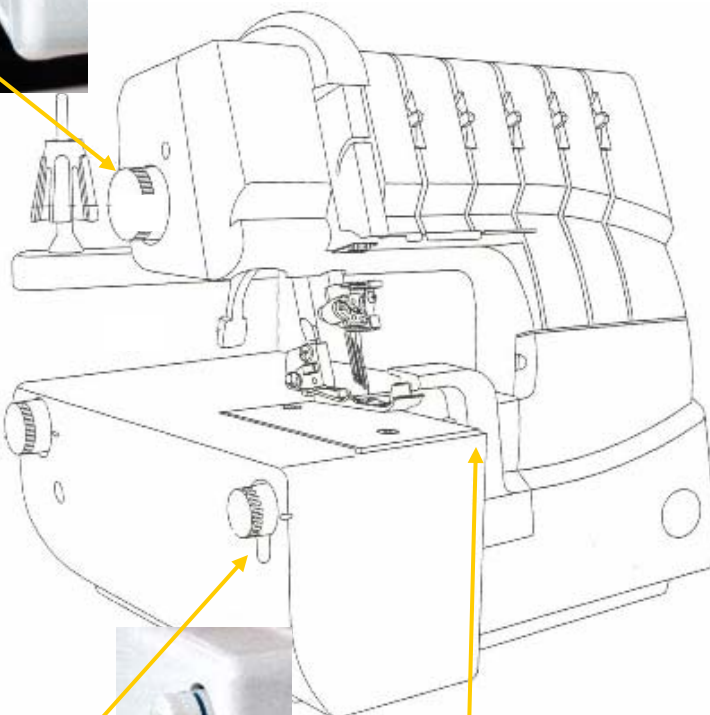

- ◆ Set Stitch Finger to “N”.

# SINGER®

## ◆ Install the Knife Cover.

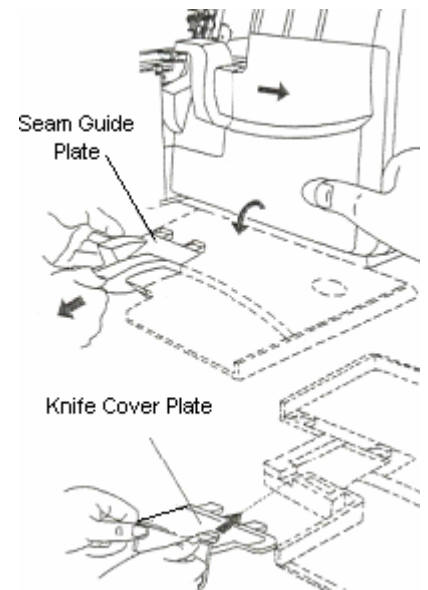

## ◆ Engage Upper Loper. Engaging the Upper Loper causes the looper to move when sewing. Even though the Upper Loper is not threaded it needs to be engaged.

1. Push the clutch button to the left and down to engage.
2. Turn handwheel.

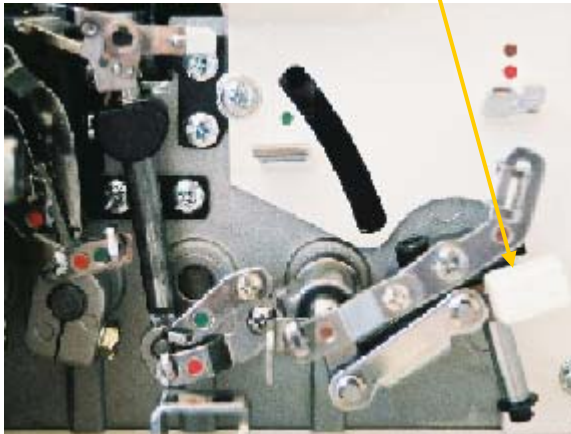

Upper Loper Disengaged

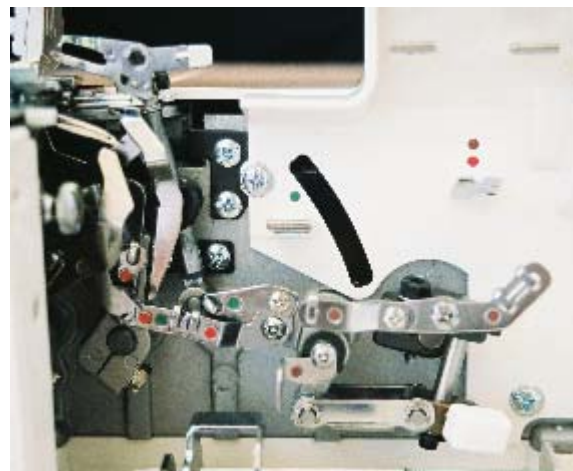
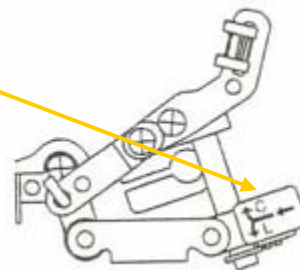

Upper Loper Engaged

- ◆ Disengage Spreader. The Upper Looter has a hole for the thread on the top of the looper. If the stitch requires that the looper be engaged but not threaded then the Spreader is used. The Spreader simply plugs-in (or closes) the looper's hole. The Spreader is disengaged when the Upper Looter is engaged/operative and threaded. The Spreader is used with a stitch that requires only one looper thread. With the help of the Spreader the single looper thread wraps around the fabric's edge.

1. Lower the white handle on the Spreader to open the eye of the Upper Looter.

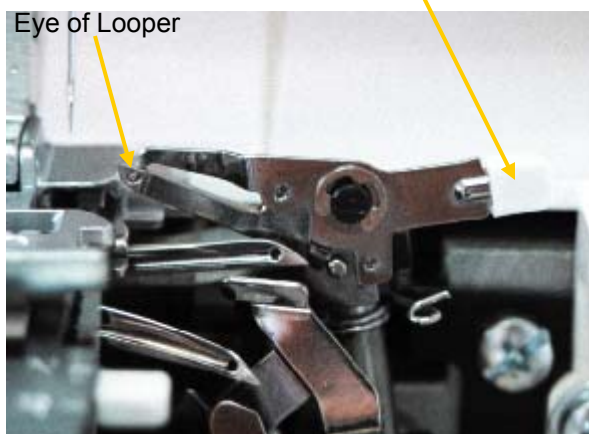

Spreader Engaged



Spreader Disengaged

- ◆ Thread Upper Looter with regular overlock thread.

1. Raise the Presser Foot to release the tension disks. Thread the Lower Looter as illustrated 1-9.

2. Pass thread from back to the front through the thread guide ①.

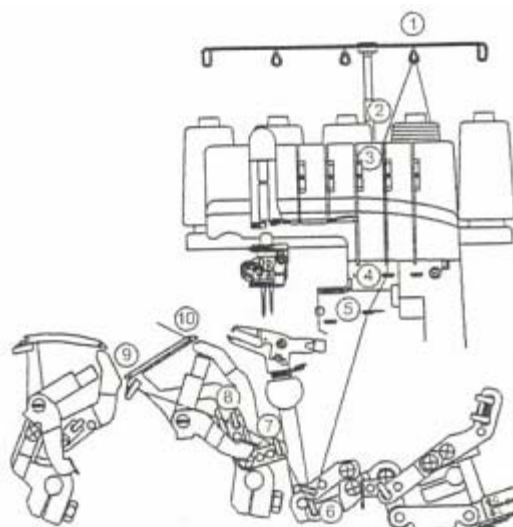
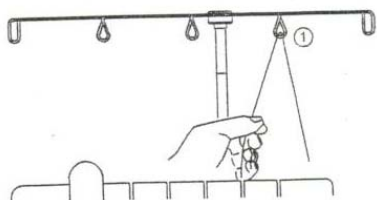

3. Thread the top cover thread guide by pulling the thread towards the left until it slips under the guide. Then pull the thread along the right side of the button as illustrated.

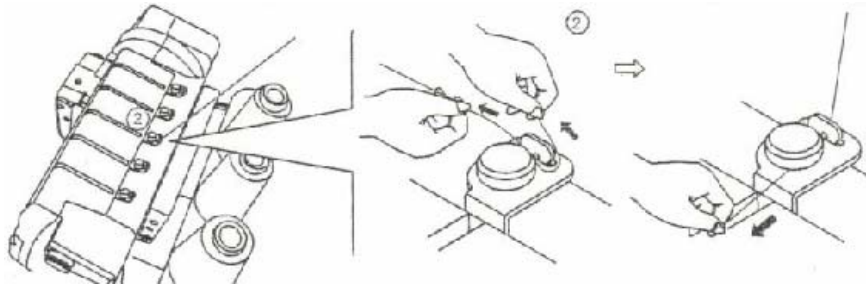

4. While holding the thread firmly, pull the thread between the tension disks.

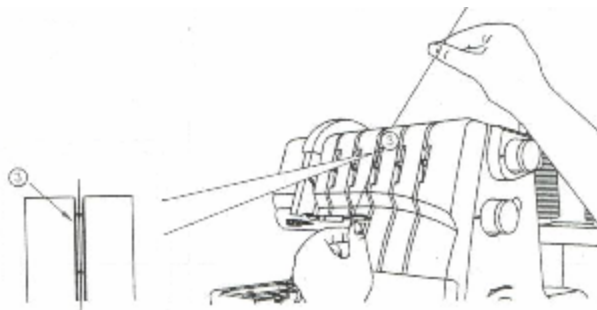

5. Turn the handwheel toward you until the lower looper extends 5-10mm (approximately ½ inch) from the needle plate edge.
6. Thread the looper area of the machine following the green color coded thread guides 4-9.

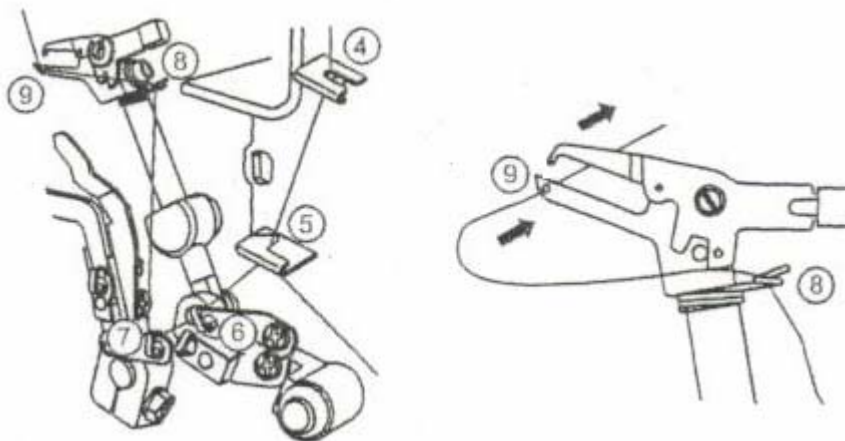



7. Thread the hole in the Upper Looter from front to back ⑨. Pull about 4 inches of thread through the looper and place to the back of the throat plate.

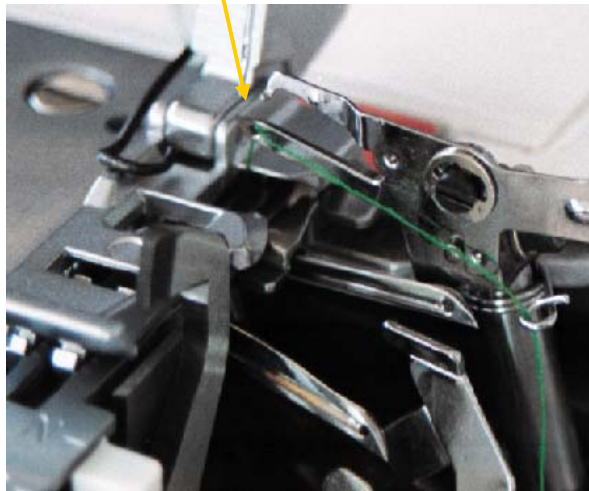

◆ Thread Lower Looter with regular overlock thread.

1. Raise the Presser foot to release the Tension disks. Thread the Lower Looter as illustrated 1-10.
2. Pass thread from back to the front through the thread guide ①.

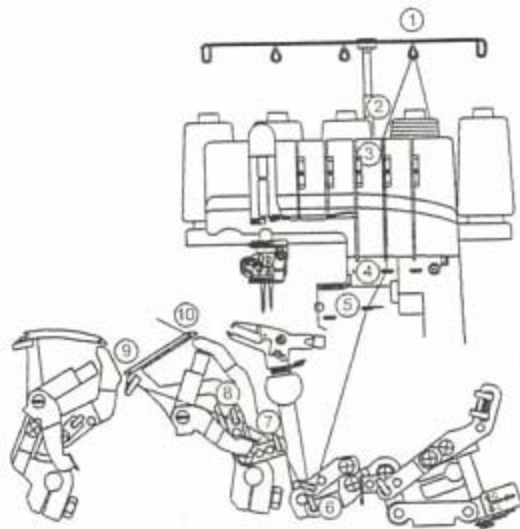
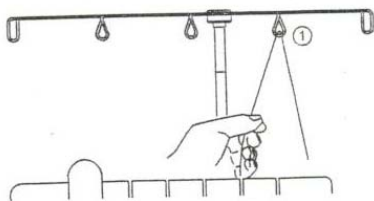

3. Thread the top cover thread guide by pulling the thread towards the left until it slips under the guide. Then pull the thread along the right side of the button as illustrated.

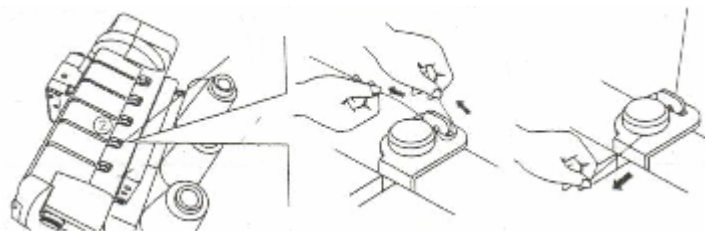

10. Thread the looper eye (A) from front to back. Pull about 4 inches of thread. Position thread into V cutout (B) on threader. Firmly hold thread tail with left hand and pull Threader lever (C) up into place (D).

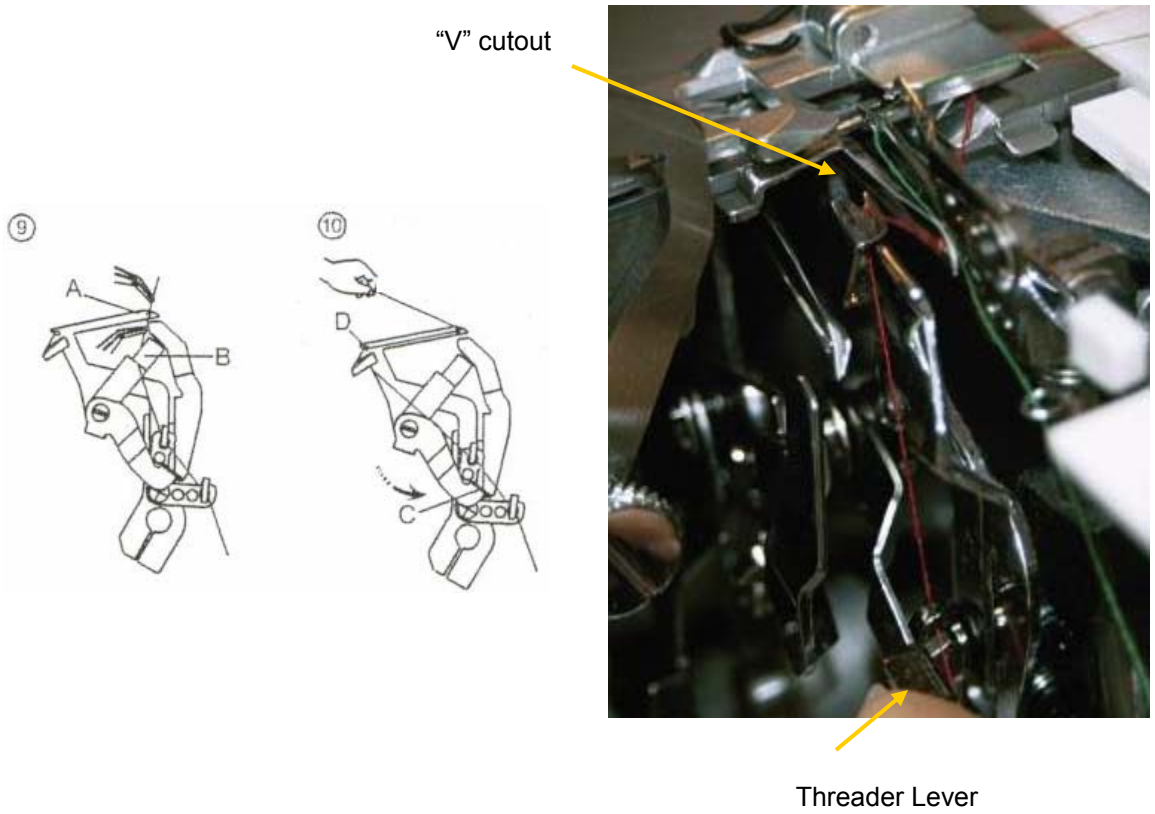

NOTE: Make sure the Upper Looper thread is behind the Lower Looper thread.

◆ Thread Right Overedge needle with regular overlock thread.

1. Raise the Presser Foot to release the tension disks. Thread the right needle as illustrated 1-9.

2. Pass thread from back to the front through the thread guide ①.

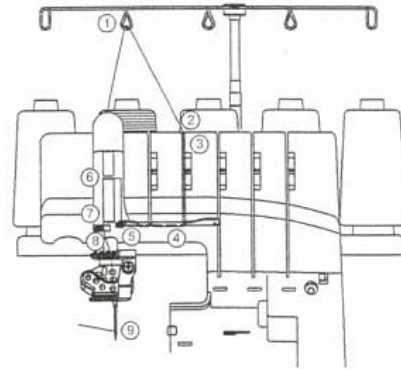
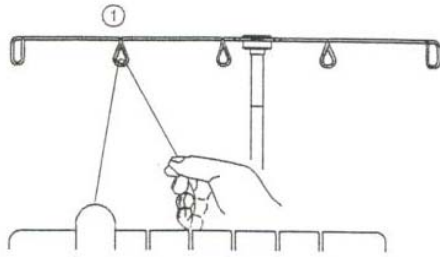

3. Thread the top cover thread guide by pulling the thread towards the left until it slips under the guide. Then pull the thread along the right side of the button as illustrated.

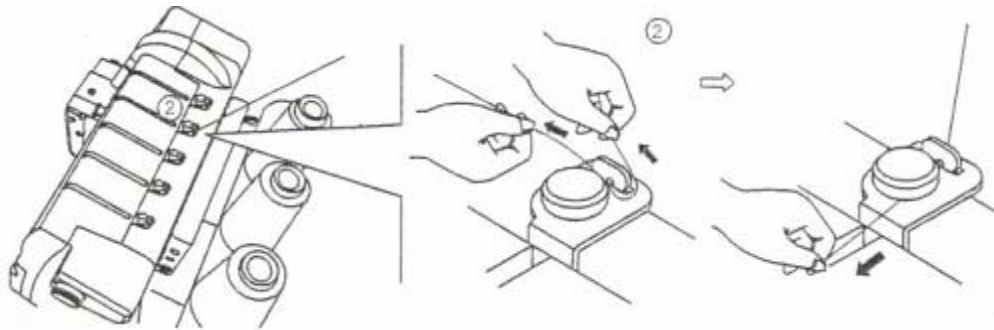

4. While holding the thread firmly, pull the thread between the tension disks.

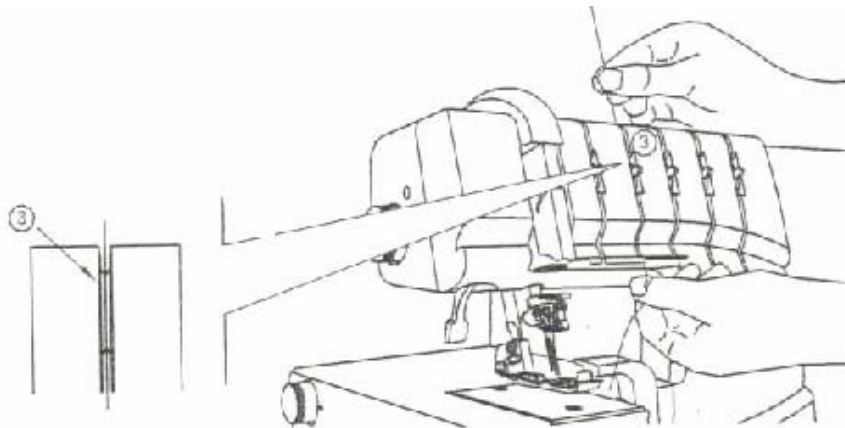

# SINGER®

5. Continue to thread points 4-8. Slip the thread into the rear slot of the thread guide ⑤. Go over the take up lever ⑥. Continue by slipping the thread into the right slot of the thread guides ⑦ and ⑧.
8. Before threading the eye of the needle, make sure the thread is behind the thread guide located on the bottom of the needle clamp.

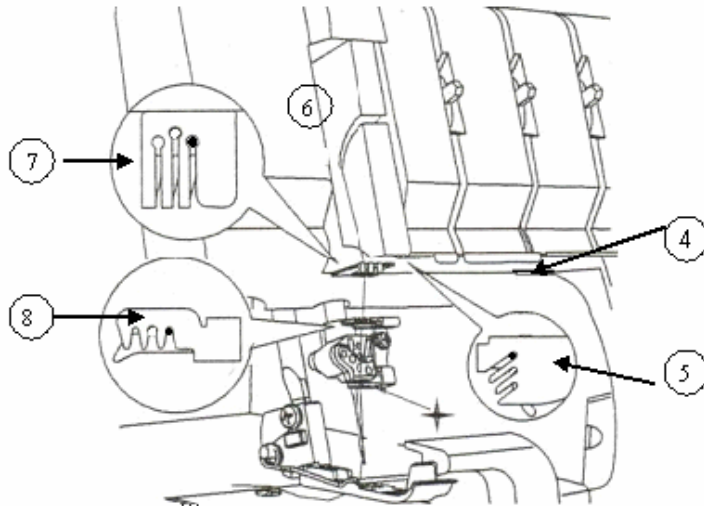

9. Draw about 4 inches of the thread through the needle eye towards the back of the machine.
10. Place the thread to the back, under the Presser Foot.

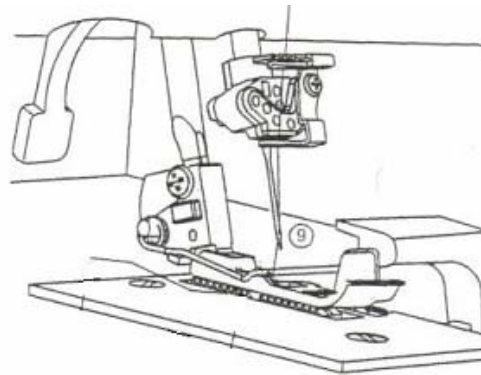

# SINGER®

## Try It:

- ◆ Fold T-shirt interlock fabric wrong sides together lengthwise.
- ◆ Align the fabric so that the fabric's fold is not being trimmed by the knife.
- ◆ Sew.
- ◆ Gently pull the fabric flat and press.

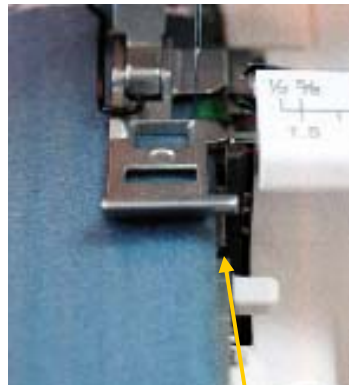
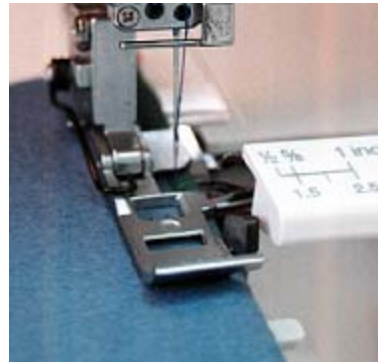

Hint:  
If the fabric is not laying flat, align the fabric farther to the left of the knife.

## Three-Thread Flatlock (Wide)

The Three-Thread Flatlock (wide) has the same set up as the Three-Thread Flatlock (narrow) Stitch. The only exception is the Right Overedge Needle is now unthreaded and removed and the Left Overedge Needle is threaded. By using the left needle, the stitch becomes wider.

Left Overedge Needle Thread

Right Overedge Needle Thread



## Set up:

### Needle:

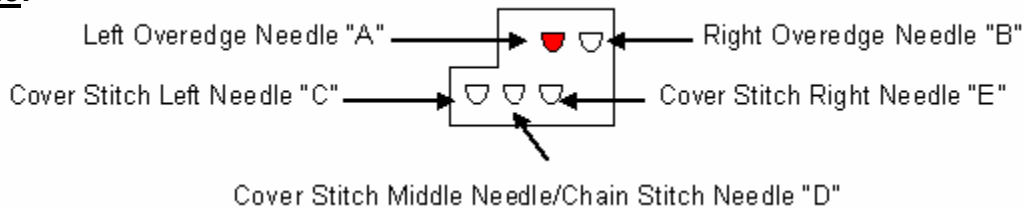

### Set at:

<b>ATD:</b> Auto Tension Dial	"F"
Left Cover Stitch Needle "C"	Unthreaded and Remove Needle
Middle Cover Stitch Needle "D"	Unthreaded and Remove Needle
Right Cover Stitch Needle "E"	Unthreaded and Remove Needle
Overedge Left Needle "A" (Orange)	Threaded
Overedge Right Needle "B"	Unthreaded and Remove Needle
Upper Looper (Green)	Looper Engaged and Threaded
Spreader	Disengage
Lower Looper (Red)	Threaded
Chain Stitch Looper (Brown)	Unthreaded
Upper Knife	Engaged
Seam Guide Plate	Not Installed, use Knife Cover Plate
Seam Width Dial	"N"
Stitch Length Dial	"2"
Presser Foot Pressure	"N"
Differential Feed Dial	"N"
Stitch Finger	"N"

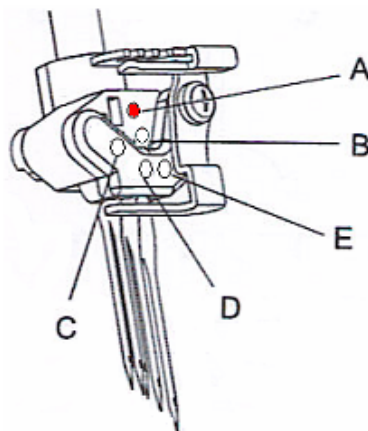

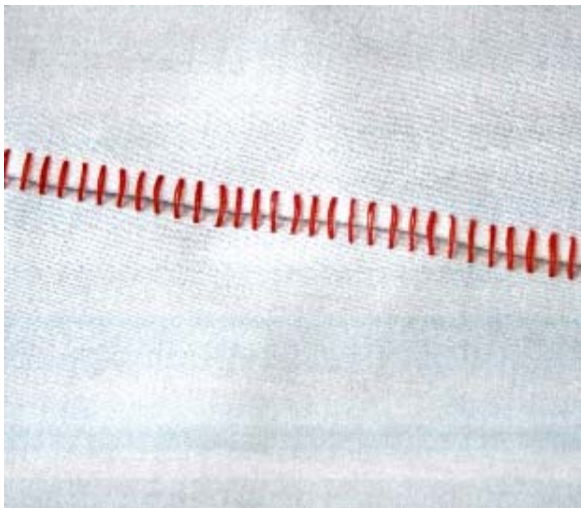
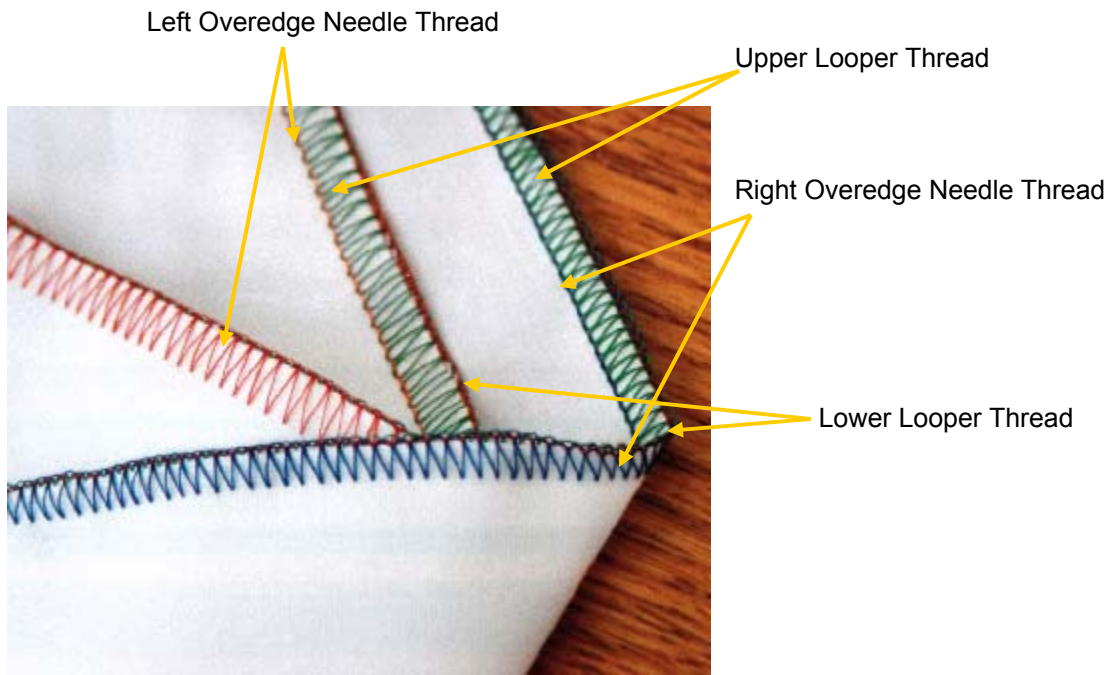

Decorative Ladder Effect (wide)  
Fabric Right Sides Together

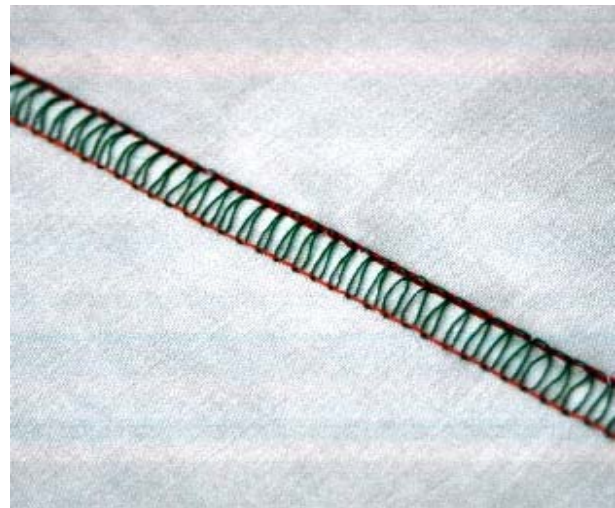

Decorative Loop Effect (wide)  
Fabric Wrong Sides Together



◆ Thread Left Overlock needle with regular thread.

1. Raise the Presser Foot to release the tension disks. Thread the left needle as illustrated 1-9.

2. Pass thread from back to the front through the thread guide ①.

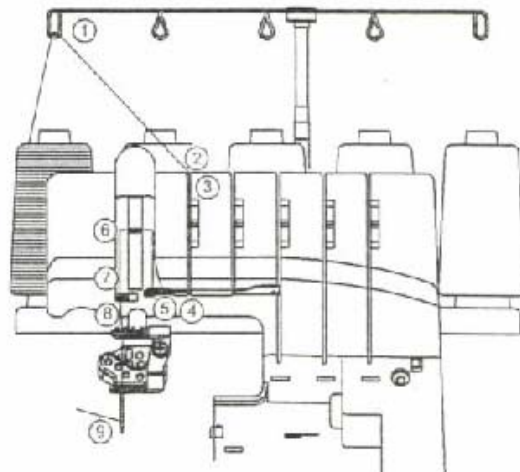
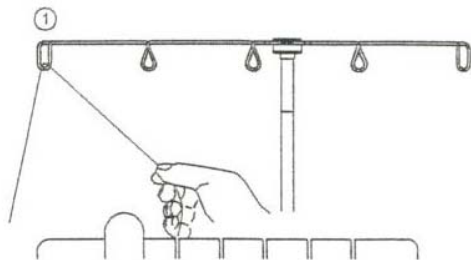

3. Thread the top cover thread guide by pulling the thread towards the left until it slips under the guide. Then pull the thread along the right side of the button as illustrated.

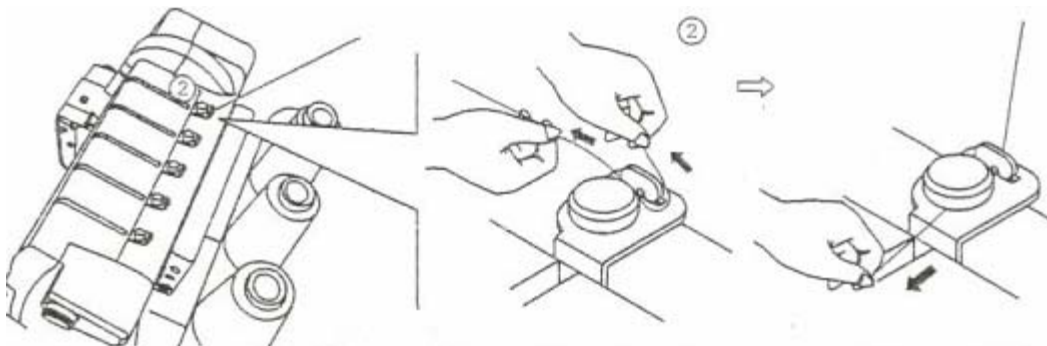

4. While holding the thread firmly, pull the thread between the tension disks.

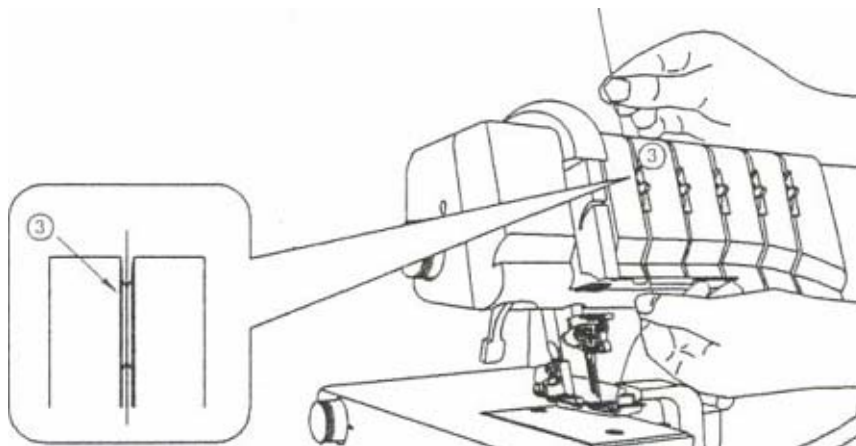

5. Continue to thread points 4-8. Slip the thread into the middle slot of the thread guide ⑤. Go over the take up lever ⑥. Continue by slipping the thread into the middle slot of the thread guides ⑦ and ⑧.
6. Before threading the eye of the needle, make sure the thread is behind the thread guide located on the bottom of the needle clamp.

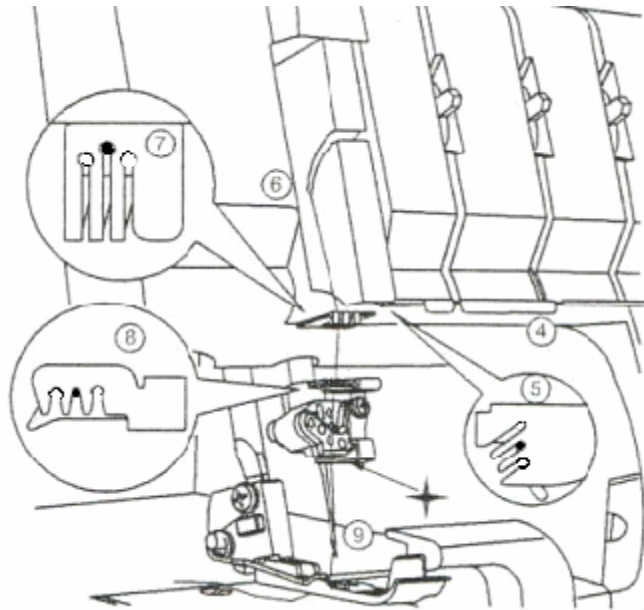

7. Thread the eye of the left needle ⑨.

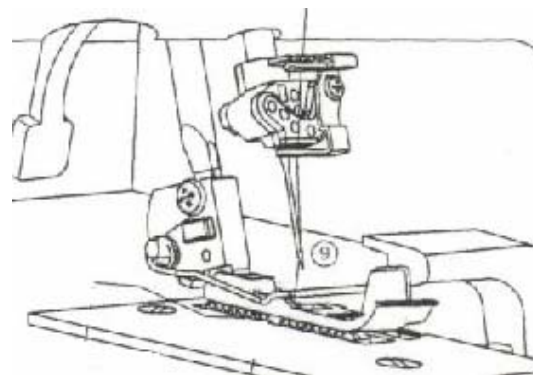

8. Draw about 4 inches of the thread through the needle eye towards the back of the machine.
9. Place the thread to the back, under the Presser Foot. Lower foot and sew.

## Try It:

- ◆ Fold sweatshirt fabric wrong sides together, lengthwise.
- ◆ Align the fabric so that the fabric's fold is not being trimmed by the knife.
- ◆ Sew.
- ◆ Gently pull the fabric flat and press.



Hint:  
If the fabric is not laying flat, align  
the fabric farther to the left of the  
knife.

## Three-Thread Ultra-Stretch Mock Safety Stitch

This stitch stretches with the fabric, the seam will not break when the fabric is stretched. It is ideal for super-stretch knits like those used on swimwear or athlete clothing. This stitch uses two needles and one looper.



Left Overedge Needle Thread

Right Overedge Needle Thread

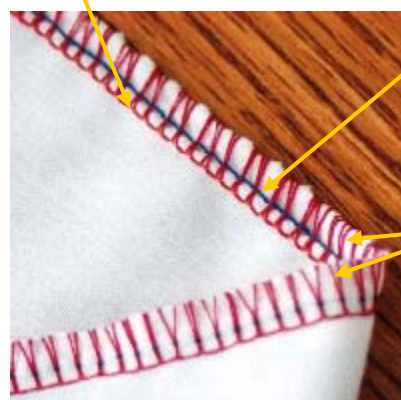

Lower Loper Thread

## Set up:

### Needle:

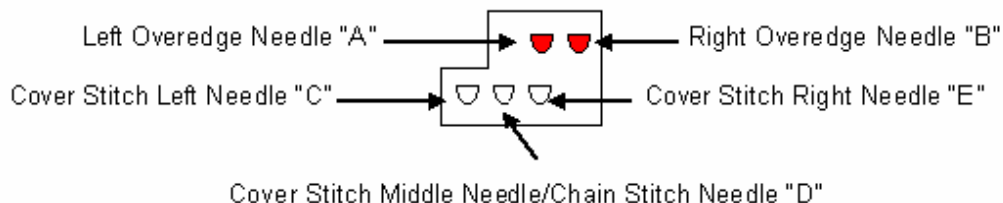

### Set at:

<b>ATD:</b> Auto Tension Dial	"G"
Left Cover Stitch Needle "C"	Not Threaded
Middle Cover Stitch Needle "D"	Not Threaded
Right Cover Stitch Needle "E"	Not Threaded
Overedge Left Needle "A" (Orange)	Threaded
Overedge Right Needle "B" (Blue)	Threaded
Upper Looper (Green)	Looper Engaged and Not Threaded
Spreader	Engaged
Lower Looper (Red)	Threaded
Chain Stitch Looper (Brown)	Not Threaded
Upper Looper Clutch	"L"
Upper Knife	Engaged
Seam Guide Plate	Not Installed Use Knife Guide
Seam Width Dial	"N"
Stitch Length Dial	"2"
Presser Foot Pressure	"N"
Differential Feed Dial	"N"
Stitch Finger	"N"

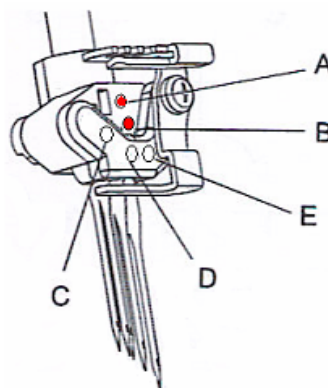

- ◆ Turn Auto Tension Dial to “G”.

- ◆ Turn Stitch Length Dial to “2”.

- ◆ Engage Upper Knife.

The knife will not trim the fabric when it is disengaged.

1. Open Looper Cover.
2. Pull the movable knife holder (silver screw) to the right as far as it will go.
3. Turn the holder clockwise until the knife clicks into a lock position.

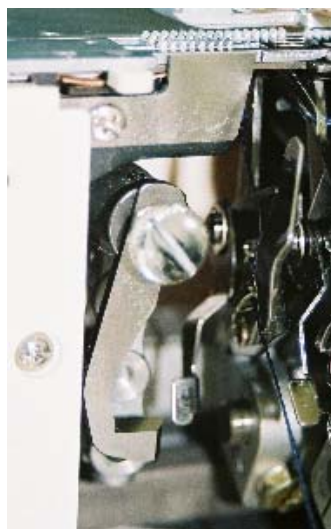
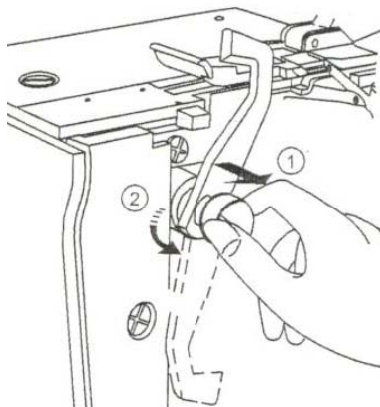

Upper Knife Disengaged



Upper Knife Engaged

- ◆ Turn Presser Foot Pressure Dial to “N”.



- ◆ Turn Differential Feed Dial to “N”.



- ◆ Turn Seam Width Dial to “N”.



- ◆ Set Stitch Finger to “N”.



◆ Install the Knife Cover.

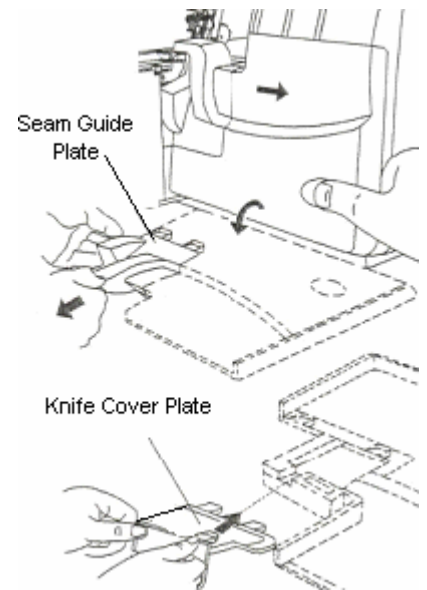

◆ Engage Upper Looper. Engaging the Upper Looper causes the looper to move when sewing. Even though the Upper Looper is not threaded it needs to be engaged.

1. Push the clutch button to the left and down to engage.
2. Turn handwheel.

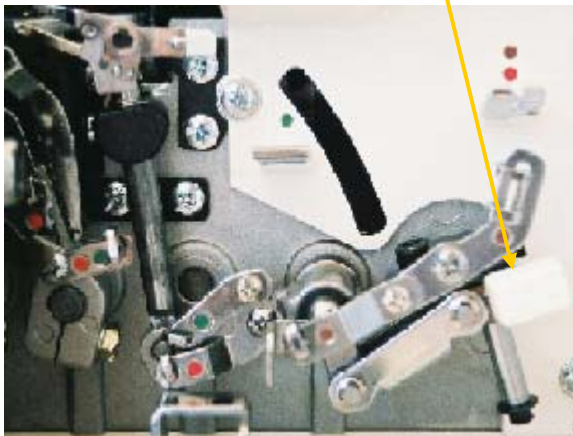
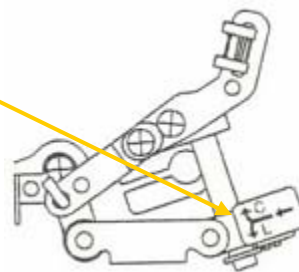

Upper Looper Disengaged

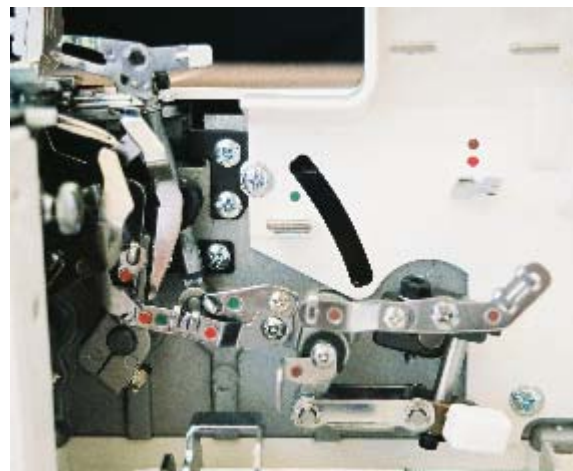

Upper Looper Engaged



- ◆ Engage Spreader. The Upper Loper has a hole for the thread on the top of the looper. If the stitch requires that the looper be engaged, but not threaded then the Spreader is used. The Spreader simply plugs-in (or closes) the looper's hole. The Spreader is disengaged when the Upper Loper is engaged/operative and threaded. The Spreader is used with a stitch that requires only one looper thread. With the help of the Spreader the single looper thread wraps around the fabric's edge.
  1. Raise the white handle on the Spreader to insert the tip into the eye of the Upper Loper.

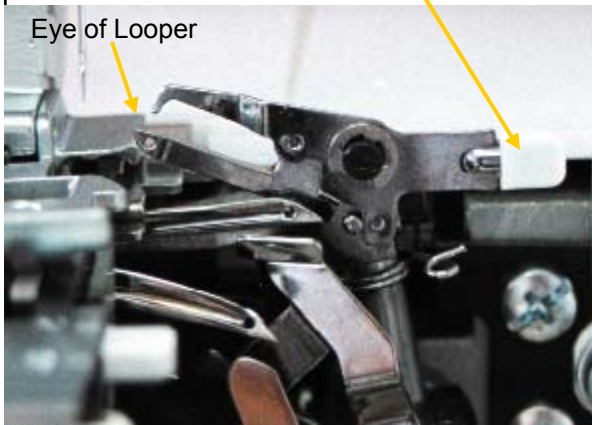

Spreader Disengaged



Spreader Engaged

- ◆ Thread Lower Loper with regular overlock thread.
  1. Raise the Presser Foot to release the Tension disks. Thread the Lower Loper as illustrated 1-10.
  2. Pass thread from back to the front through the thread guide.

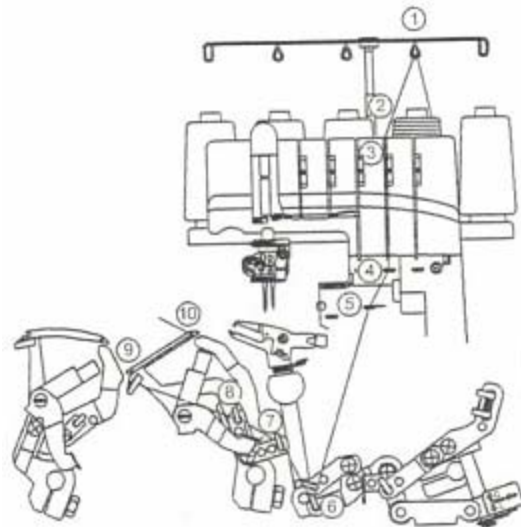
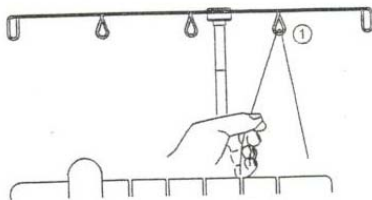

3. Thread the top cover thread guide by pulling the thread towards the left until it slips under the guide. Then pull the thread along the right side of the button as illustrated.

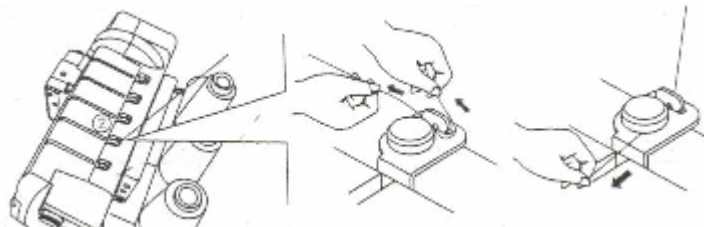

4. While holding the thread, firmly pull the thread between the tension disks.

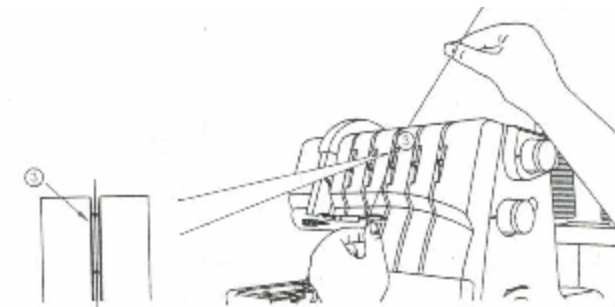

5. Turn the handwheel toward you until the lower looper extends 5-10mm (approximately 1/2 inch) from the needle plate edge.
6. Thread the looper area of the machine following the red color coded thread guides 4-10.

7. Place the thread slightly from left and to the right of threading guide ④.

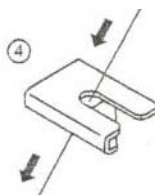

8. Place the thread slightly from the front and to the back of threading guide ⑤.



9. Place the thread through ⑥, ⑦, and ⑧.

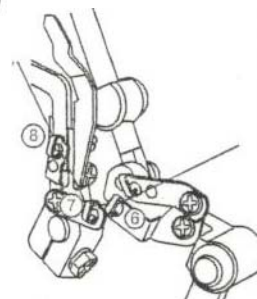

10. Thread the looper eye (A) from front to back. Pull about 4 inches of thread. Position thread into V cutout (B) on threader. Firmly hold thread tail with left hand and pull Threader lever (C) up into place (D).

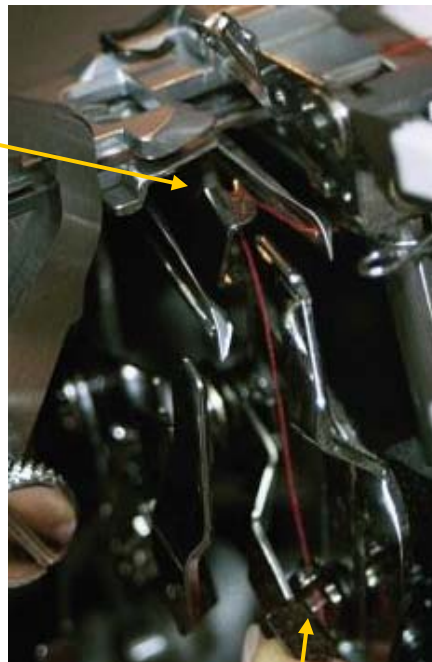
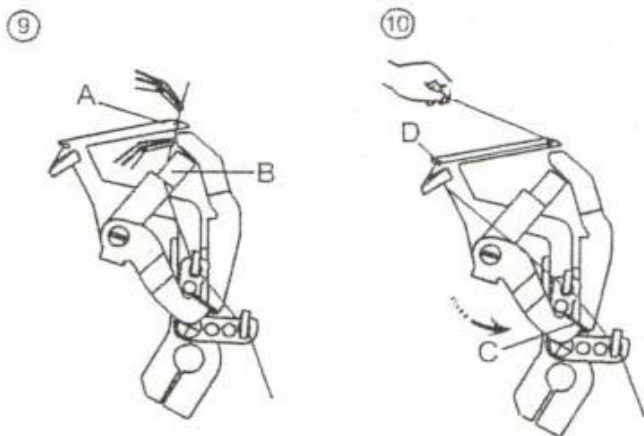

Threader Lever

◆ Thread Right Overedge needle with regular overlock thread.

1. Raise the Presser Foot to release the tension disks. Thread the right needle as illustrated 1-9.
2. Pass thread from back to the front through the thread guide ①.

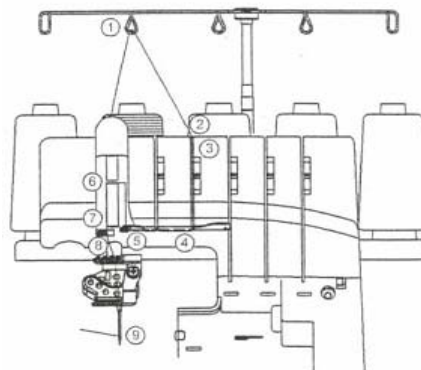
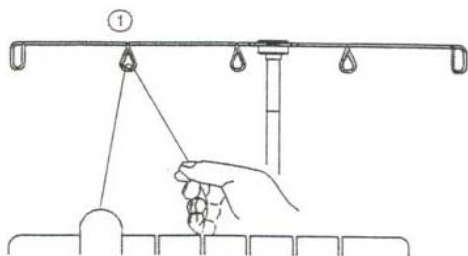

3. Thread the top cover thread guide by pulling the thread towards the left until it slips under the guide. Then pull the thread along the right side of the button as illustrated.

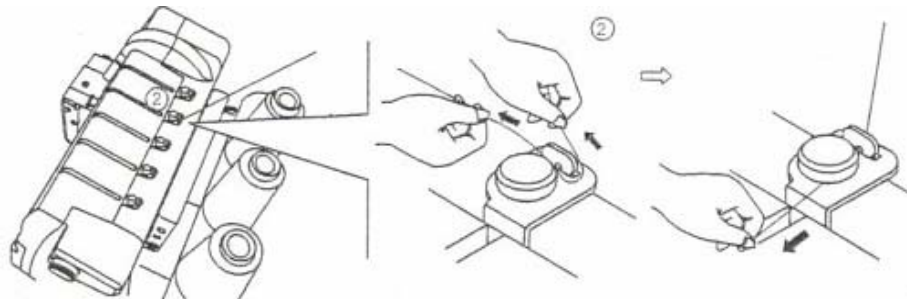

4. Continue to thread points 4-8. Slip the thread into the rear slot of the thread guide ⑤. Go over the take up lever ⑥. Continue by slipping the thread into the right slot of the thread guides ⑦ and ⑧.

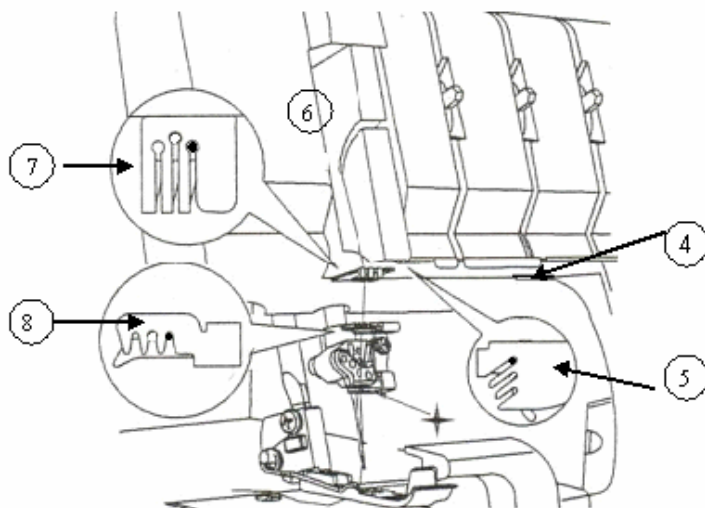

5. Before threading the eye of the needle, make sure the thread is behind the thread guide located on the bottom of the needle clamp.

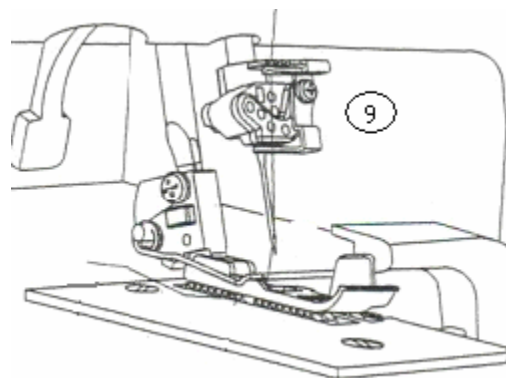

◆ Thread Left Overedge needle with regular thread.

1. Raise the Presser foot to release the tension disks. Thread the left needle as indicated 1-9.

2. Pass thread from back to the front through the thread guide ①.

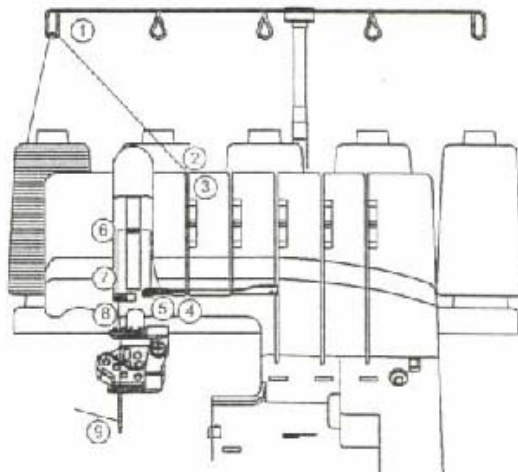
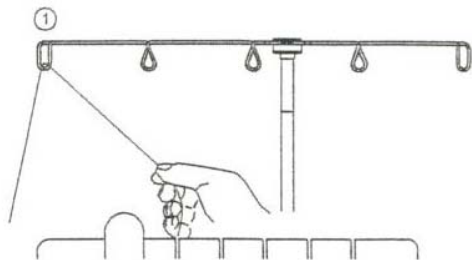

3. Thread the top cover thread guide by pulling the thread towards the left until it slips under the guide. Then pull the thread along the right side of the button as illustrated.

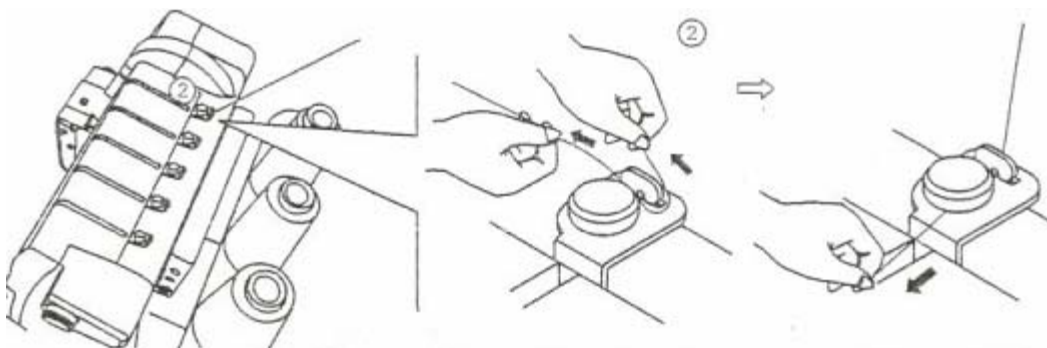

4. While holding the thread firmly, pull the thread between the tension disks.

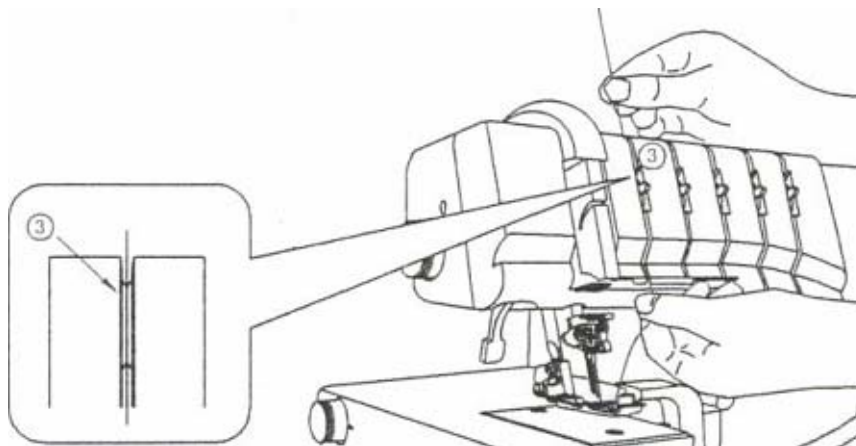

5. Continue to thread points 4-8. Slip the thread into the middle slot of the thread guide ⑤. Go over the take up lever ⑥. Continue by slipping the thread into the middle slot of the thread guides ⑦ and ⑧.
6. Before threading the eye of the needle, make sure the thread is behind the thread guide located on the bottom of the needle clamp.

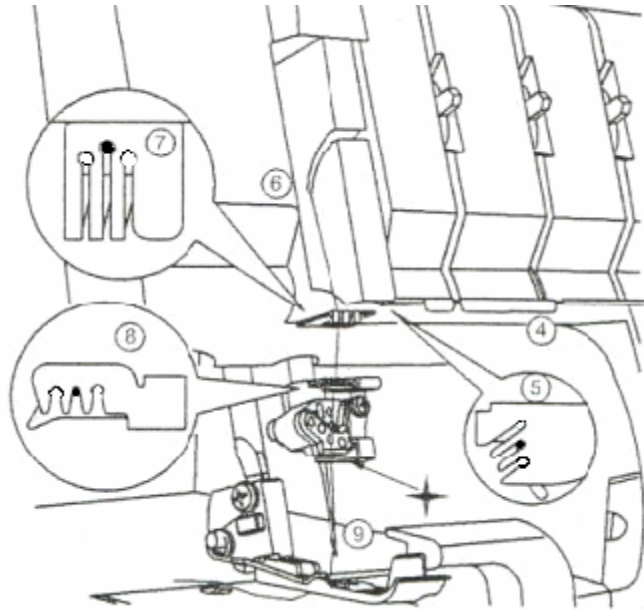

7. Thread the eye of the Left Overedge Needle ⑨.

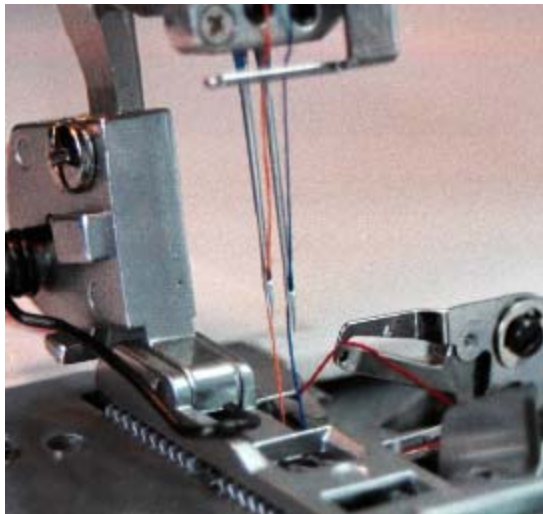

8. Draw about 4 inches of the thread through the needle eye towards the back of the machine.
9. Place the thread to the back, under the Presser Foot. Lower foot and sew.

# SINGER®

## Try It:

- ◆ Align two pieces of fabric, right sides together so that the knife just slightly trims the fabric's edges.
- ◆ Sew.



## Four-Thread Ultra-Stretch Mock Safety Stitch

The Four-Thread Ultra-Stretch Mock Safety Stitch is stronger than the Three-Thread Ultra-Stretch Mock Safety Stitch. The additional thread provides added strength to the seam and is good choice for knits as well as wovens. This stitch works well when applying ribbing to a garment. Ribbing is often seen on cuffs, collars and waistbands of active wear. This stitch requires two needle threads and two looper threads.



Left Overedge Needle Thread

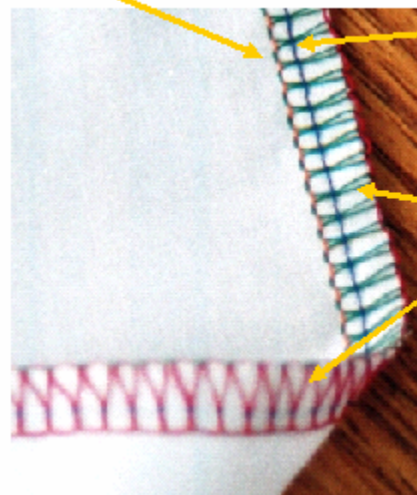

Right Overedge Needle Thread

Upper Looper Thread

Lower Looper Thread



## Set up:

### Needle:

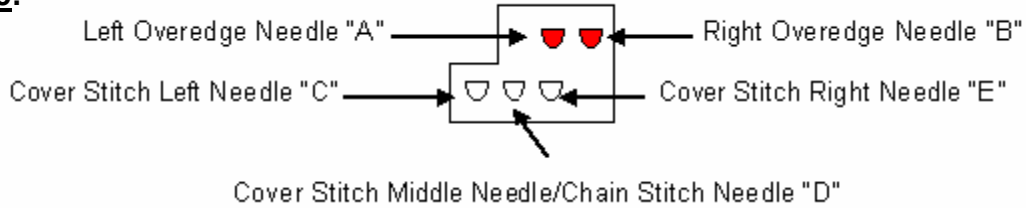

### Set at:

<b>ATD:</b> Auto Tension Dial	"A"
Left Cover Stitch Needle "C"	Not Threaded
Middle Cover Stitch Needle "D"	Not Threaded
Right Cover Stitch Needle "E"	Not Threaded
Overedge Left Needle "A" (Orange)	Threaded
Overedge Right Needle "B" (Blue)	Threaded
Upper Loper (Green)	Looper Engaged and Threaded
Spreader	Disengaged
Lower Loper (Red)	Threaded
Chain Stitch Loper (Brown)	Not Threaded
Upper Loper Clutch	"L"
Upper Knife	Engaged
Seam Guide Plate	Not Installed Use Knife Guide
Seam Width Dial	"N"
Stitch Length Dial	"N"
Presser Foot Pressure	"N"
Differential Feed Dial	"N"
Stitch Finger	"N"

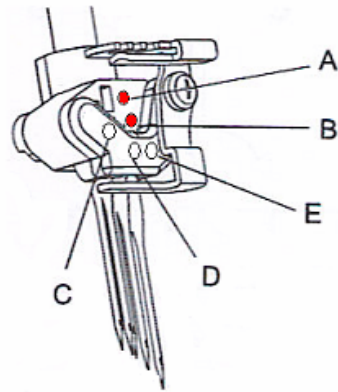

Sweatshirt sample



- ◆ Turn Auto Tension Dial to “A”.

- ◆ Turn Stitch Length Dial to “N”.

- ◆ Engage Upper Knife.

The knife will not trim the fabric when it is disengaged.

1. Open Looper Cover.
2. Pull the movable knife holder (silver screw) to the right as far as it will go.
3. Turn the holder clockwise until the knife clicks into a lock position.

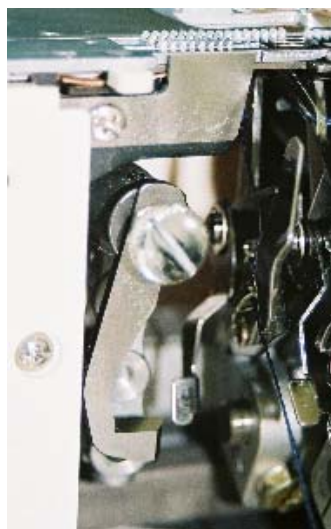
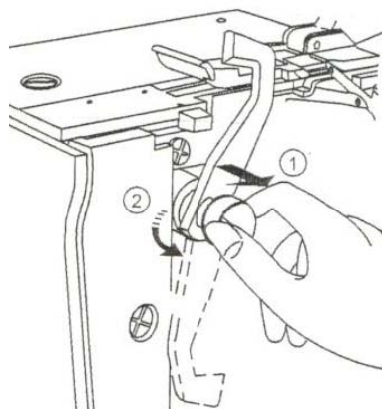

Upper Knife Disengaged



Upper Knife Engaged

# SINGER®

- ◆ Turn Presser Foot Pressure Dial to “N”.



- ◆ Turn Differential Feed Dial to “N”.



- ◆ Turn Seam Width Dial to “N”.



- ◆ Set Stitch Finger to “N”.



◆ Install the Knife Cover.

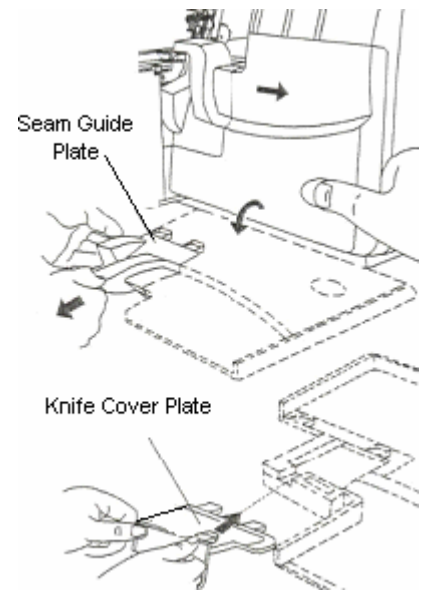
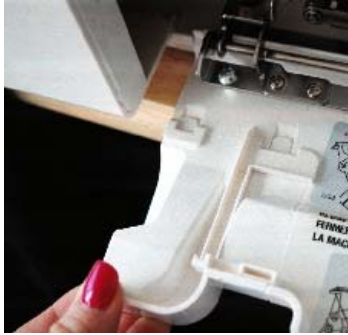

◆ Engage Upper Looper. Engaging the Upper Looper causes the looper to move when sewing. Even though the Upper Looper is not threaded, it needs to be engaged.

1. Push the clutch button to the left and down to engage.
2. Turn handwheel.

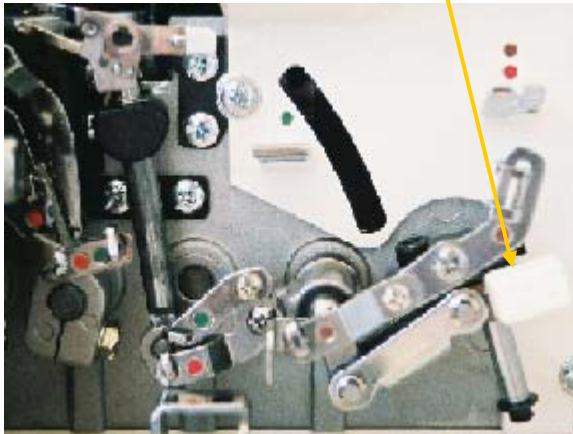
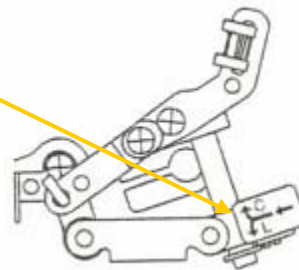

Upper Looper Disengaged

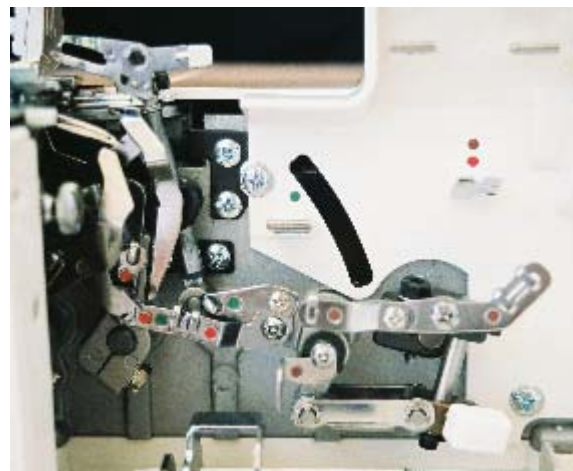

Upper Looper Engaged

- ◆ Disengage Spreader. The Upper Loper has a hole for the thread on the top of the looper. If the stitch requires that the looper be engaged but not threaded then the Spreader is used. The Spreader simply plugs-in (or closes) the looper's hole. The Spreader is disengaged when the Upper Loper is engaged/operative and threaded. The Spreader is used with a stitch that requires only one looper thread. With the help of the Spreader the single looper thread wraps around the fabric's edge.
  1. Lower the white handle on the Spreader to open the eye of the Upper Loper.

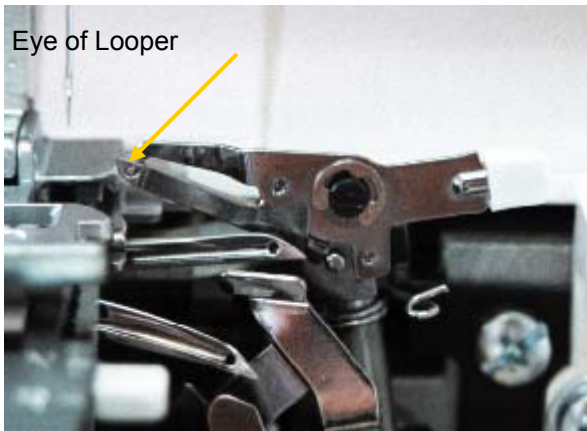

Spreader Engaged



Spreader Disengaged

- ◆ Thread Upper Loper with regular overlock thread.
  1. Raise the Presser Foot to release the tension disks. Thread the Lower Loper as illustrated 1-9.

2. Pass thread from back to the front through the thread guide ①.

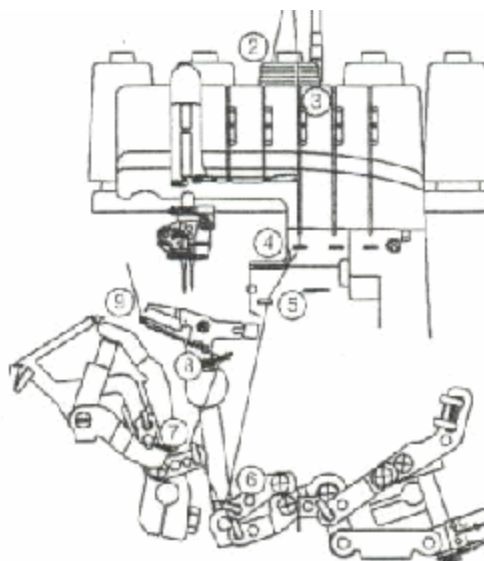
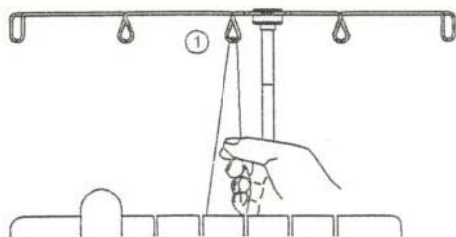

3. Thread the top cover thread guide by pulling the thread towards the left until it slips under the guide. Then pull the thread along the right side of the button as illustrated.

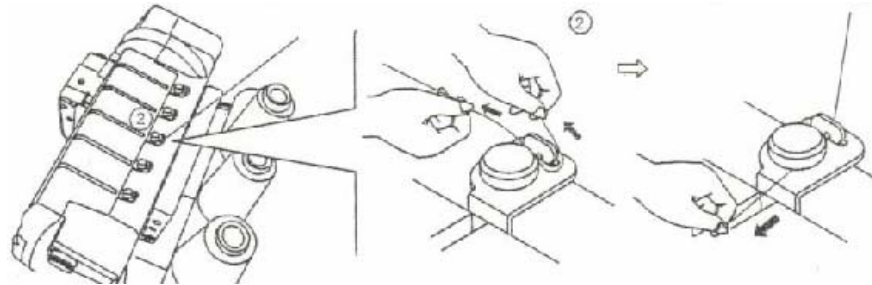

4. While holding the thread firmly, pull the thread between the tension disks.

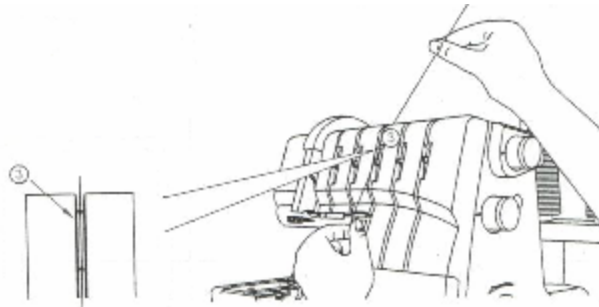

5. Turn the handwheel toward you until the lower looper extends 5-10mm (approximately 1/2 inch) from the needle plate edge.

6. Thread the looper area of the machine following the green color coded thread guides 4-9.

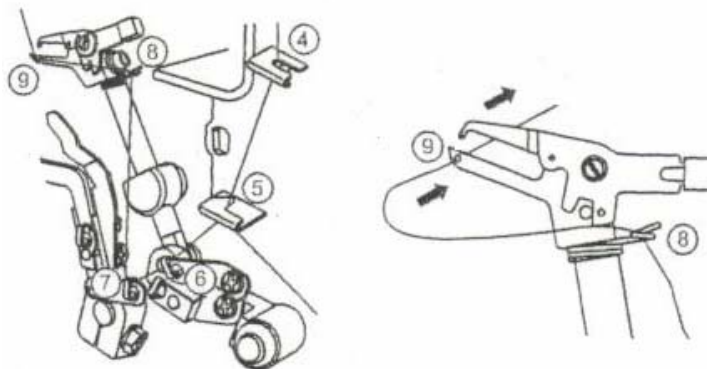

7. Thread the hole in the Upper Looter from front to back ⑨. Pull about 4 inches of thread through the looper and place to the back of the throat plate.

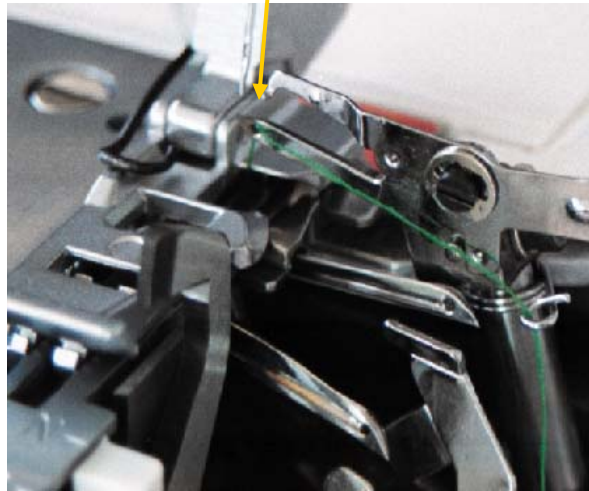

◆ Thread Lower Looter with regular overlock thread.

1. Raise the Presser Foot to release the Tension disks. Thread the Lower Looter as illustrated 1-10.
2. Pass thread from back to the front through the thread guide ①.

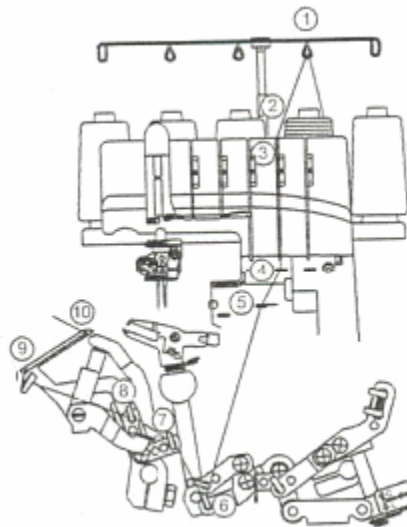
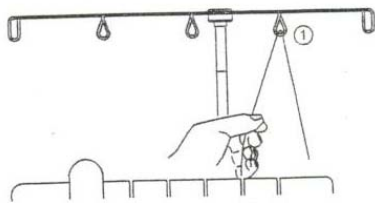



3. Thread the top cover thread guide by pulling the thread towards the left until it slips under the guide. Then pull the thread along the right side of the button as illustrated.

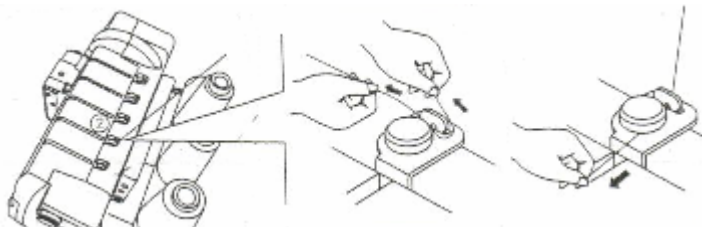

4. While holding the thread, firmly pull the thread between the tension disks.

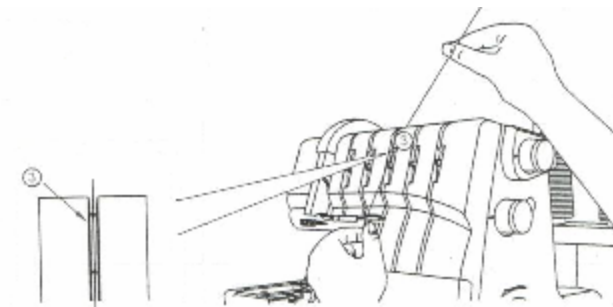

5. Turn the handwheel toward you until the lower looper extends 5-10mm (approximately 1/2 inch) from the needle plate edge.
6. Thread the looper area of the machine following the red color coded thread guides 4-10.

7. Place the thread slightly from left and to the right of threading guide ④.

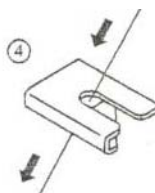

8. Place the thread slightly from the front and to the back of threading guide ⑤.



9. Place the thread through ⑥, ⑦, and ⑧.

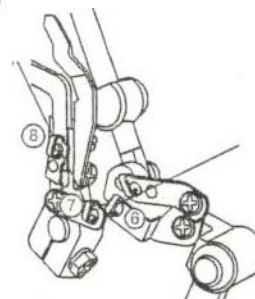

10. Thread the looper eye (A) from front to back. Pull about 4 inches of thread. Position thread into V cutout (B) on threader. Firmly hold thread tail with left hand and pull Threader lever (C) up into place (D).

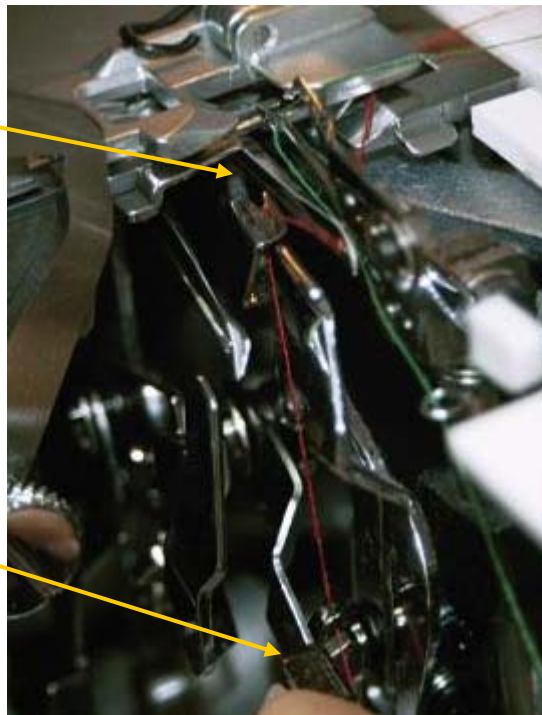
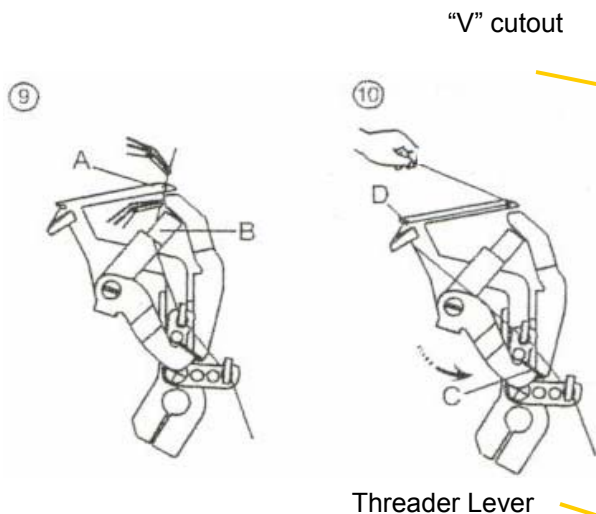

NOTE: Make sure the Upper Looper thread is behind the Lower Looper thread.

◆ Thread Right Overedge needle with regular overlock thread.

1. Raise the Presser Foot to release the tension disks. Thread the right needle as illustrated 1-9.
2. Pass thread from back to the front through the thread guide ①.

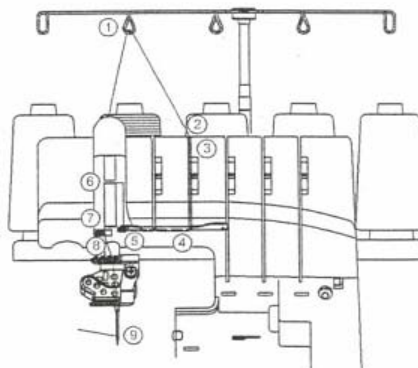
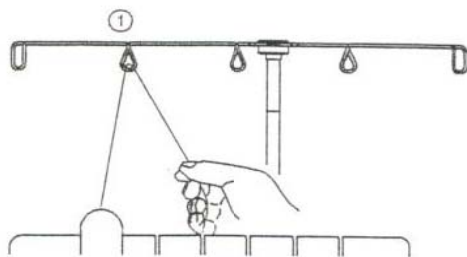

3. Thread the top cover thread guide by pulling the thread towards the left until it slips under the guide. Then pull the thread along the right side of the button as illustrated.

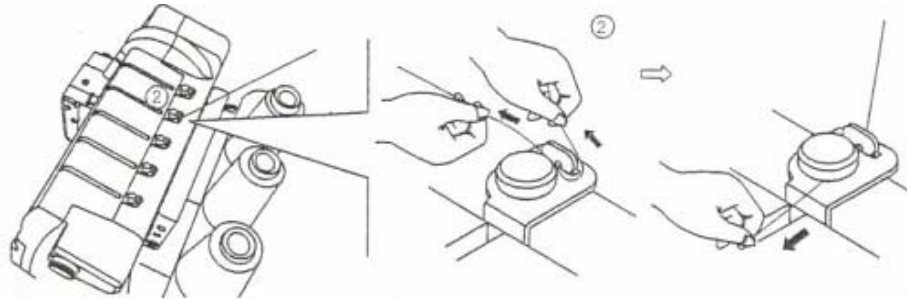

4. Continue to thread points 4-8. Slip the thread into the rear slot of the thread guide ⑤. Go over the take up lever ⑥. Continue by slipping the thread into the right slot of the thread guides ⑦ and ⑧.

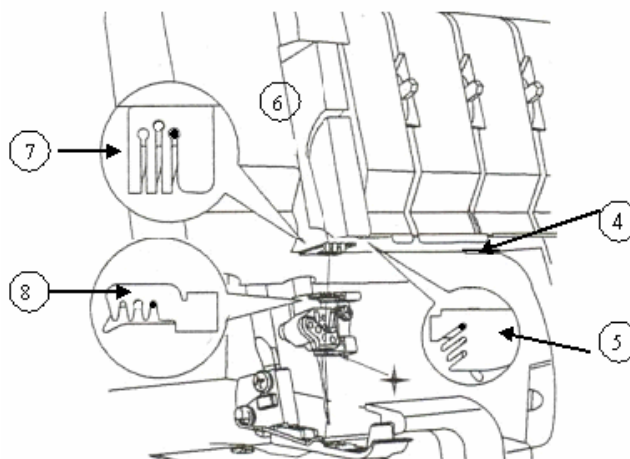

5. Before threading the eye of the needle, make sure the thread is behind the thread guide located on the bottom of the needle clamp.

6. Thread the eye of the Overedge Right Needle ⑨.

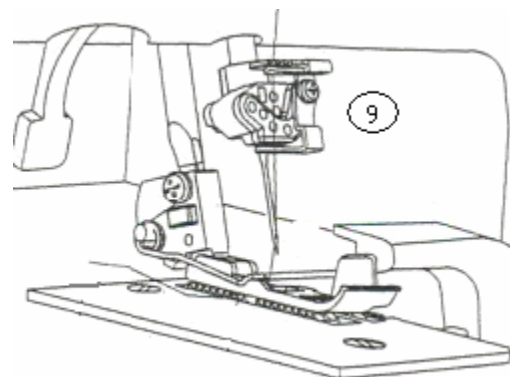

◆ Thread Left Overlock needle with regular thread.

1. Raise the Presser Foot to release the tension disks. Thread the left needle as illustrated 1-9.

2. Pass thread from back to the front through the thread guide ①.

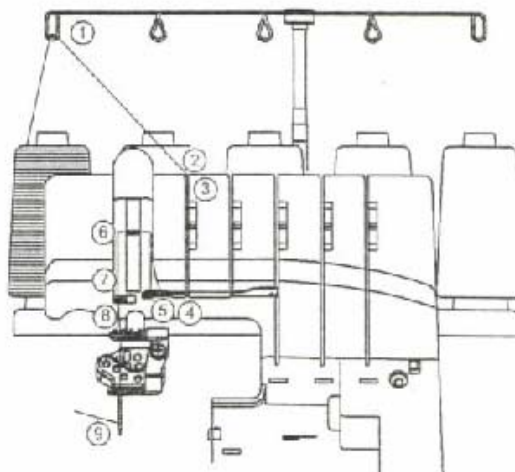
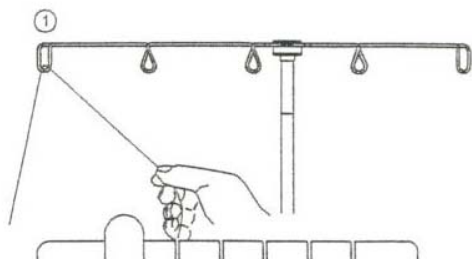

3. Thread the top cover thread guide by pulling the thread towards the left until it slips under the guide. Then pull the thread towards the right side of the button as illustrated.

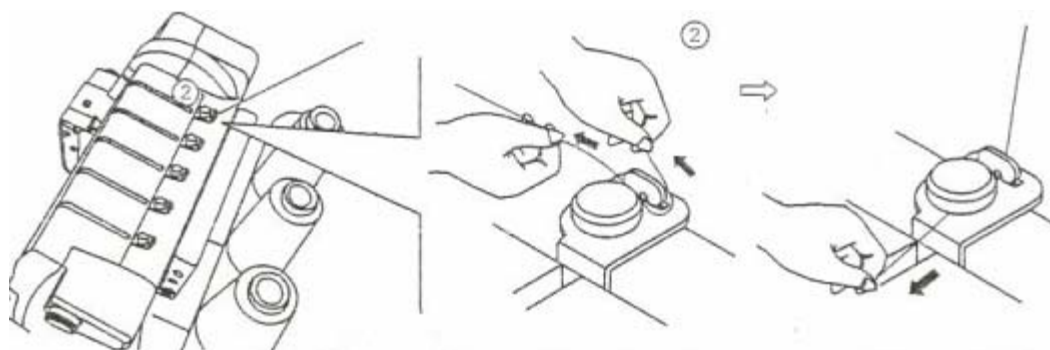

4. While holding the thread firmly, pull the thread between the tension disks.

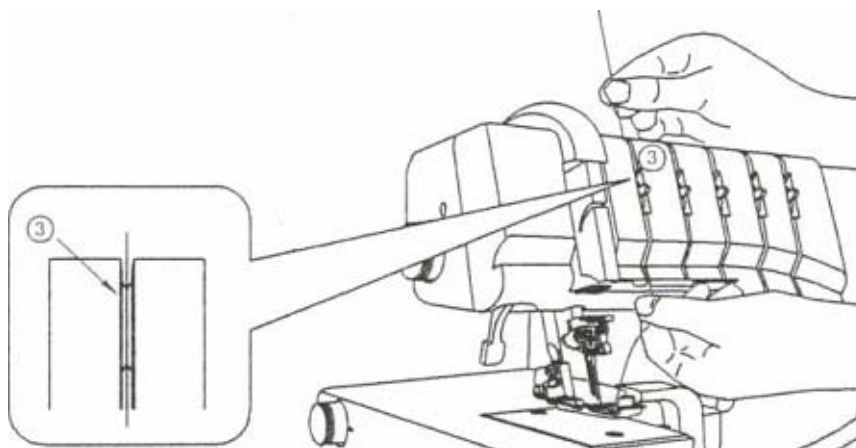

5. Continue to thread points 4-8. Slip the thread into the middle slot of the thread guide ⑤. Go over the take up lever ⑥. Continue by slipping the thread into the middle slot of the thread guides ⑦ and ⑧.
6. Before threading the eye of the needle, make sure the thread is behind the thread guide located on the bottom of the needle clamp.

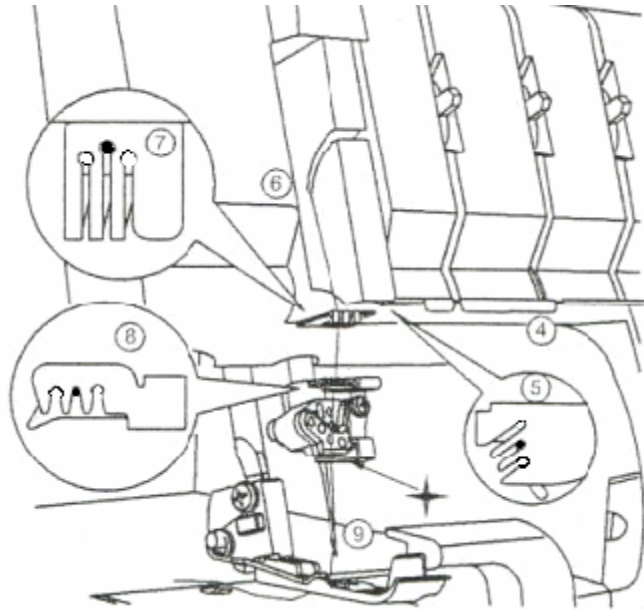

7. Thread the eye of the Left Overedge Needle ⑨.

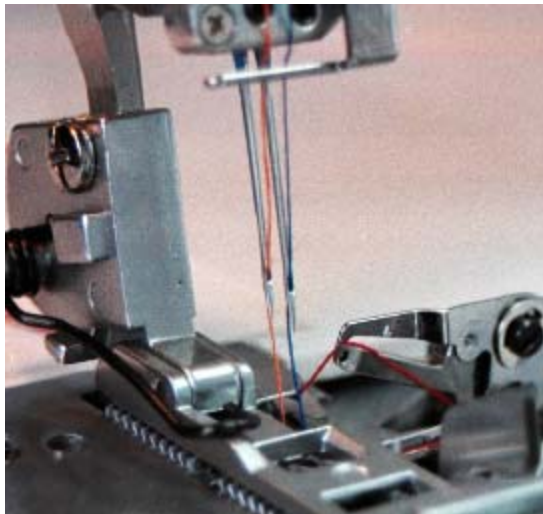

8. Draw about 4 inches of the thread through the needle eye towards the back of the machine.
9. Place the thread to the back, under the Presser Foot. Lower foot and sew.

# SINGER®

## Try It:

- ◆ Fold ribbing lengthwise.
- ◆ Place ribbing on top of fleece.
- ◆ Align the fabric so that the knife just slightly trims both the ribbing and fleece fabric edges.
- ◆ Sew, stretching the ribbing as needed.



## Four-Thread Safety Stitch

This stitch is an alternative to the Five-Thread Safety Stitch. It offers the same type of Two-Thread Chainstitch. However the Three-Thread Overlock is now replaced by a Two-Thread Overedge finish. The Four-Thread Safety Stitch is appropriately used when sewing a medium weight woven fabric. Because there is one less thread being used, the stitch is less bulky. However, it is still strong enough not to require straight stitch reinforcement from a conventional sewing machine. This stitch requires two needle threads and two looper threads.

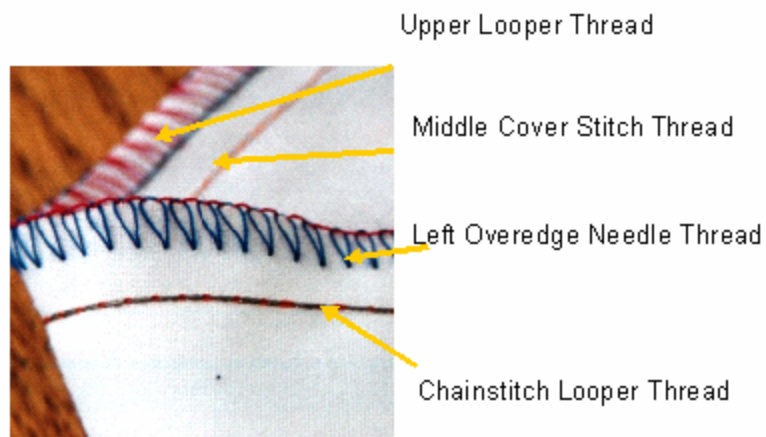

## Set up:

### Needle:

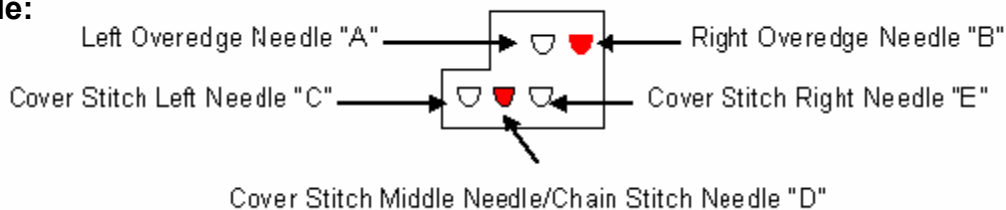

### Set at:

<b>ATD:</b> Auto Tension Dial	"I"
Left Cover Stitch Needle "C"	Not Threaded
Middle Cover Stitch Needle "D" (Orange)	Threaded
Right Cover Stitch Needle "E"	Not Threaded
Overedge Left Needle "A"	Not Threaded
Overedge Right Needle "B" (Blue)	Threaded
Upper Looper	Looper Engaged and Not Threaded
Spreader	Engaged
Lower Looper (Red)	Threaded
Chain Stitch Looper (Brown)	Threaded
Upper Looper Clutch	"L"
Upper Knife	Engaged
Seam Guide Plate	Not Installed
Seam Width Dial	"N"
Stitch Length Dial	"N"
Presser Foot Pressure	"N"
Differential Feed Dial	"N"
Stitch Finger	"N"

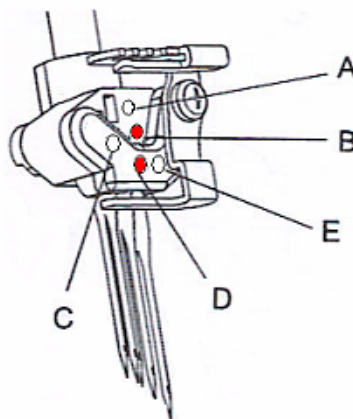



- ◆ Turn Auto Tension Dial to “I”.

- ◆ Turn Stitch Length Dial to “N”.

- ◆ Engage Upper Knife.

The knife will not trim the fabric when it is disengaged.

1. Open Looper Cover.
2. Pull the movable knife holder (silver screw) to the right as far as it will go.
3. Turn the holder clockwise until the knife clicks into a lock position.

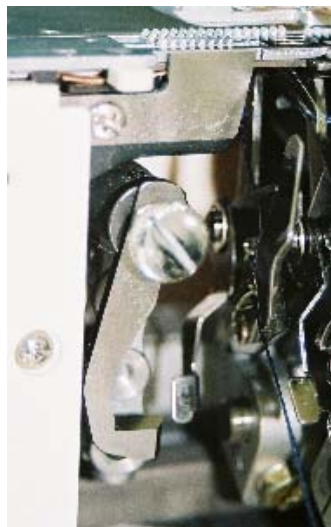
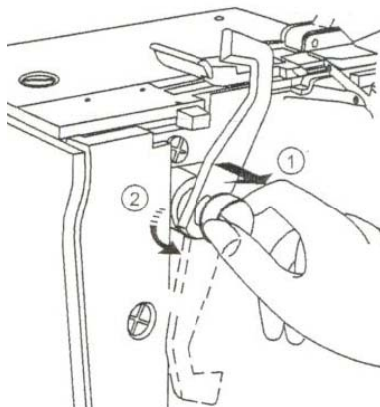
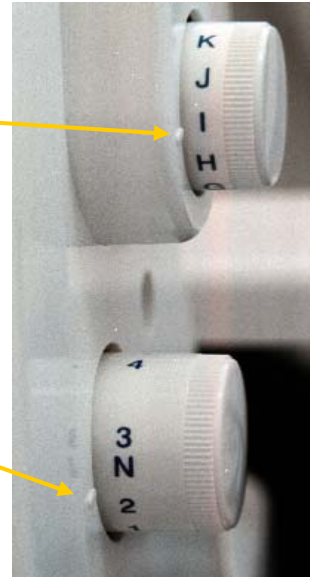

Upper Knife Disengaged



Upper Knife Engaged

# SINGER®

- ◆ Turn Presser Foot Pressure Dial to “N”.



- ◆ Turn Differential Feed Dial to “N”.



- ◆ Turn Seam Width Dial to “N”.

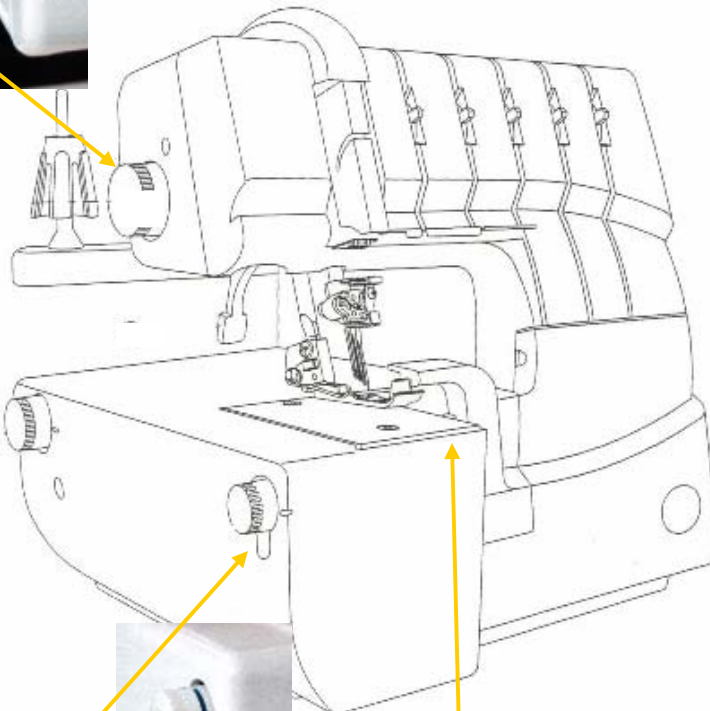

- ◆ Set Stitch Finger to “N”.

# SINGER®

## ◆ Install the Knife Cover.

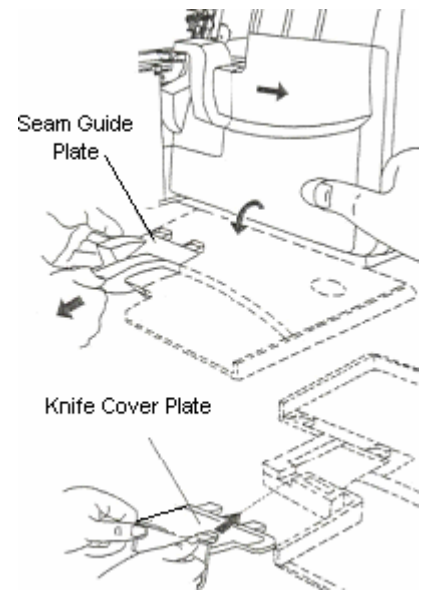

## ◆ Engage Upper Looper. Engaging the Upper Looper, causes the looper to move when sewing. Even though the Upper Looper is not threaded it needs to be engaged.

1. Push the clutch button to the left and down to engage.
2. Turn handwheel.

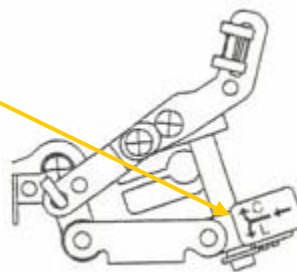

Upper Looper Disengaged

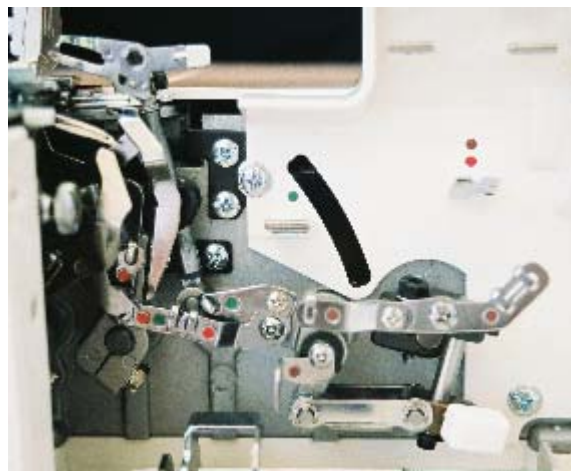

Upper Looper Engaged

- ◆ Engage Spreader. The Upper Loper has a hole for the thread on the top of the looper. If the stitch requires that the looper be engaged, but not threaded then the Spreader is used. The Spreader simply plugs-in (or closes) the looper's hole. The Spreader is disengaged when the Upper Loper is engaged/operative and threaded. The Spreader is used with a stitch that requires only one looper thread. With the help of the Spreader the single looper thread wraps around the fabric's edge.

1. Raise the white handle on the Spreader to insert the tip into the eye of the Upper Loper.

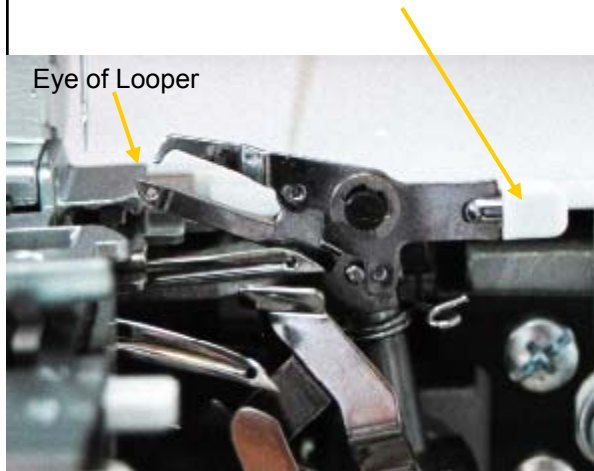

Spreader Disengaged



Spreader Engaged

- ◆ Thread Lower Loper with regular overlock thread.

1. Raise the Presser Foot to release the tension disks. Thread the Lower Loper as illustrated 1-10.

2. Pass thread from back to the front through the thread guide ①.

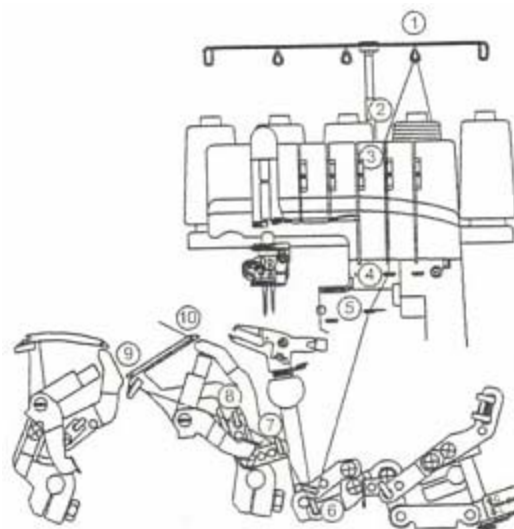
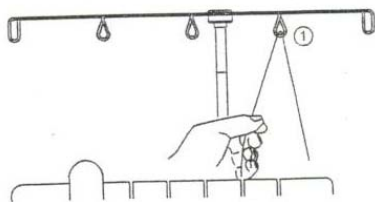

3. Thread the top cover thread guide by pulling the thread towards the left until it slips under the guide. Then pull the thread along the right side of the button as illustrated.

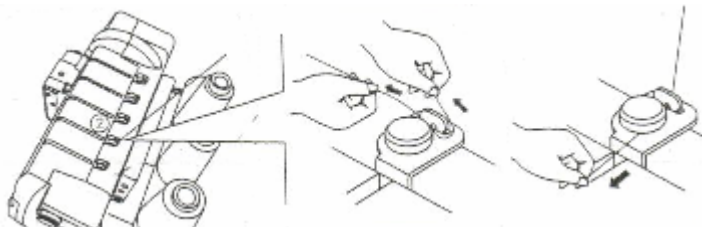

4. While holding the thread, firmly pull the thread between the tension disks.

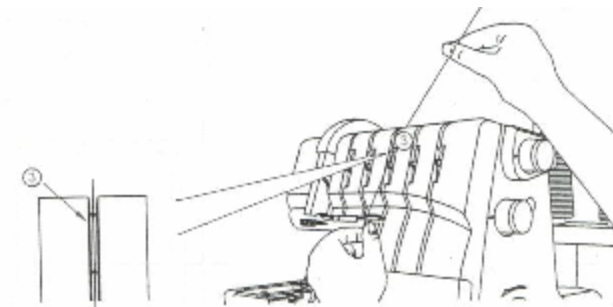

5. Turn the handwheel toward you until the lower looper extends 5-10mm (approximately 1/2 inch) from the needle plate edge.
6. Thread the looper area of the machine following the red color coded thread guides 4-10.

7. Place the thread slightly from left and to the right of threading guide ④.

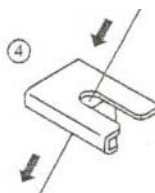

8. Place the thread slightly from the front and to the back of threading guide ⑤.



9. Place the thread through ⑥, ⑦, and ⑧.

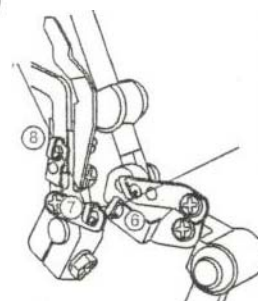

10. Thread the looper eye (A) from front to back. Pull about 4 inches of thread. Position thread into V cutout (B) on threader. Firmly hold thread tail with left hand and pull Threader lever (C) up into place (D).

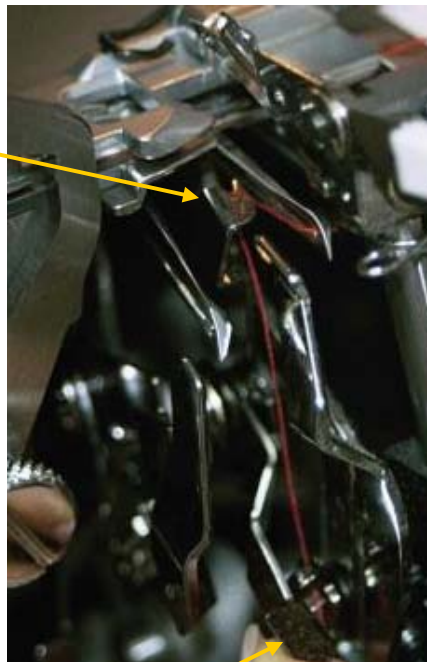
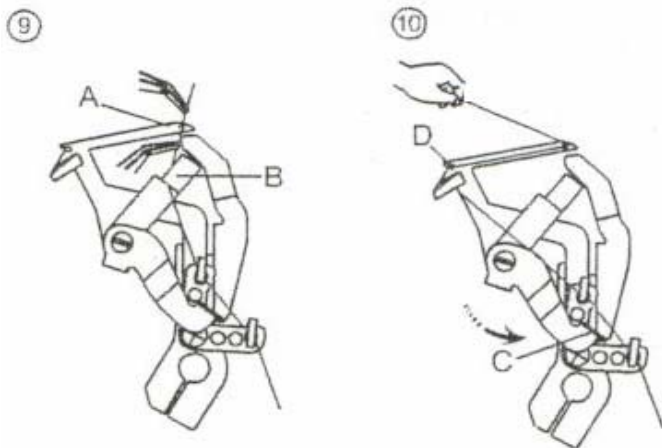

Threader Lever

◆ Thread Chainstitch Looper with regular overlock thread.

1. Raise the Presser Foot to release the tension disks. Pass the thread from the back to the front through the thread guide ①.

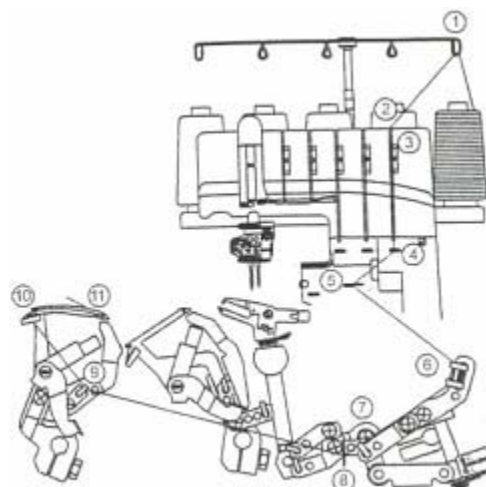
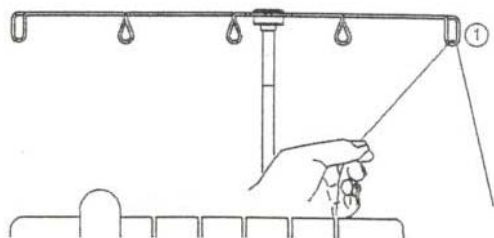

# SINGER®

2. Thread the top cover thread guide by pulling the thread towards the left until it slips under the guide. Then pull thread along the right side of the button, as illustrated.

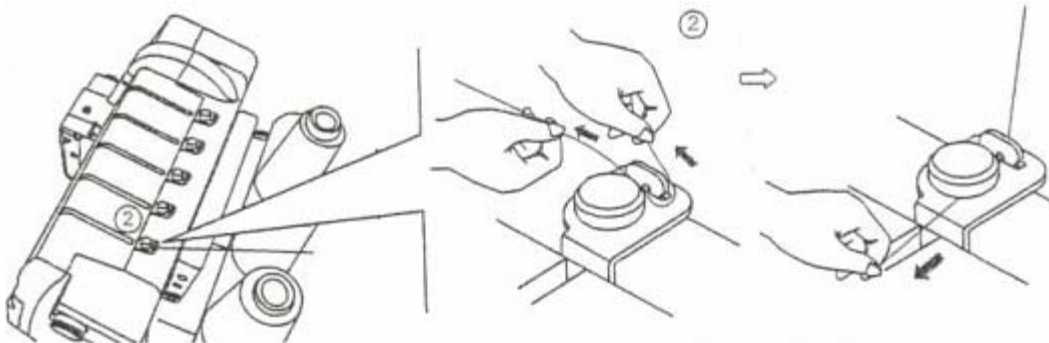

3. While holding the thread, firmly pull the thread between the tension disks.

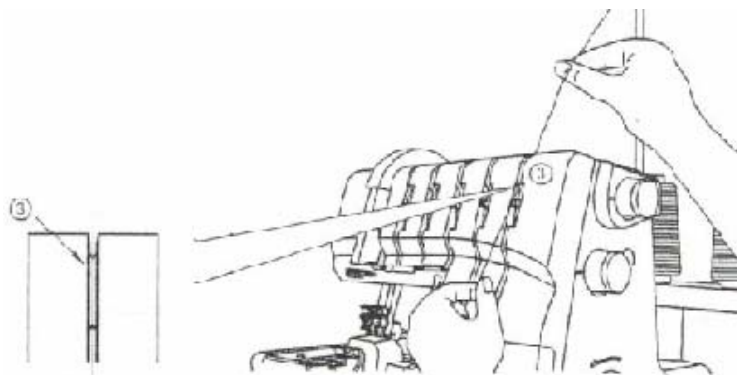

4. Turn the hand wheel toward you until the Chainstitch Looper extends out 10mm (approximately 1/2") from the needle plate edge.



5. Thread the looper area of the machine following the brown color-coded thread guides 4-11. Use the tweezers provided in the accessory case to aid in threading the looper.

6. Place the thread through threading guide ④ and ⑤.

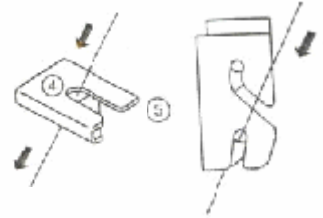

7. Continue threading guides ⑥, ⑦, ⑧ and ⑨.

8. Thread the looper eye (A) from front to back. Pull about 4 inches of thread through the looper. Position the thread into the V cutout (B) on the threader. Firmly hold the thread tail with your left hand and pull threader lever (C) up into place (D). Gently pull 5-6" of thread to the back of the machine.

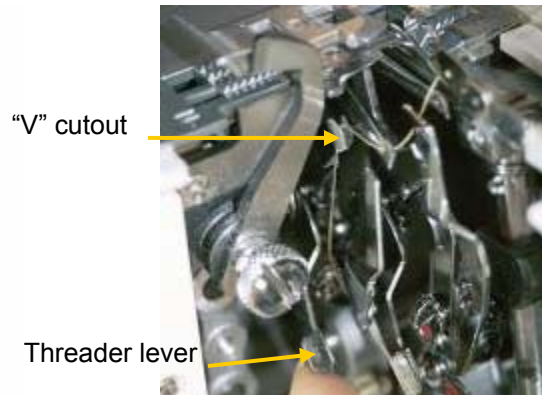
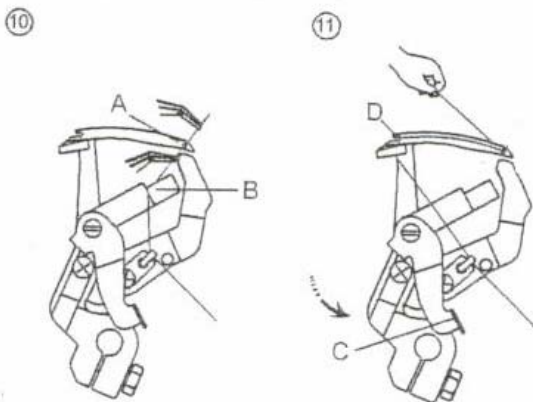

◆ Thread Right Overedge with regular overlock thread.

1. Raise the Presser Foot to release the tension disks. Thread the right needle as illustrated 1-9.

2. Pass thread from back to the front through the thread guide ①.

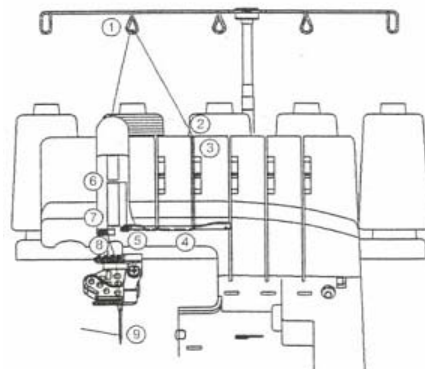
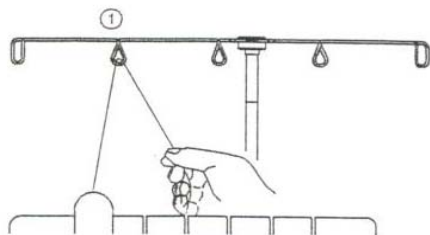



3. Thread the top cover thread guide by pulling the thread towards the left until it slips under the guide. Then pull the thread along the right side of the button as illustrated.

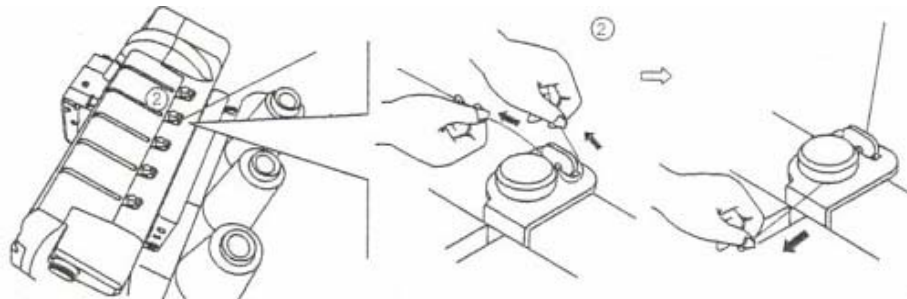

4. Continue to thread points 4-8. Slip the thread into the rear slot of the thread guide ⑤. Go over the take up lever ⑥. Continue by slipping the thread into the right slot of the thread guides ⑦ and ⑧.

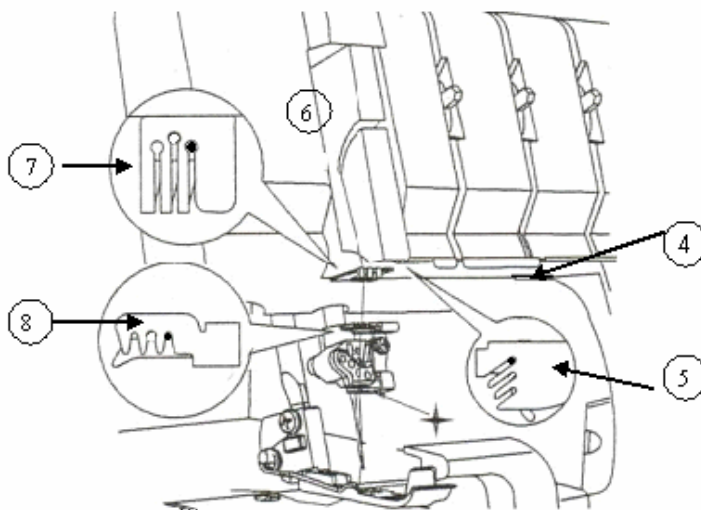

5. Before threading the eye of the needle, make sure the thread is behind the thread guide located on the bottom of the needle clamp.
6. Thread the eye of the Right Overedge Needle ⑨.

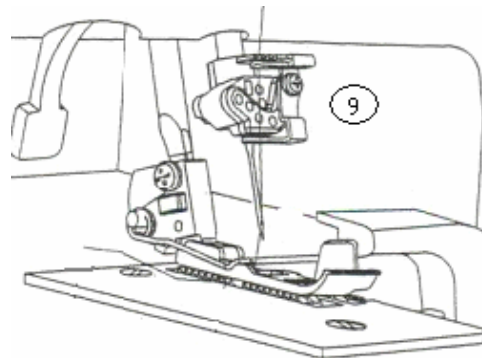
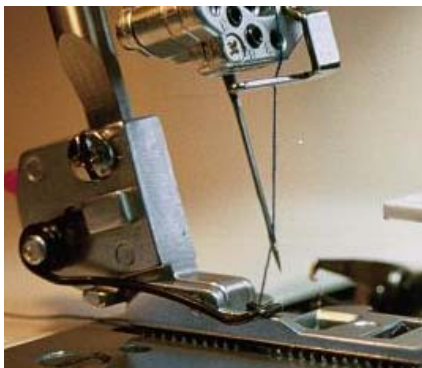

◆ Thread Middle Cover Stitch with regular overlock thread.

1. Raise the Presser Foot to release the tension disks. Thread the Cover Stitch Middle/Chain Stitch needle as illustrated 1-9.
2. Pass thread from back to the front through the thread guide ①.

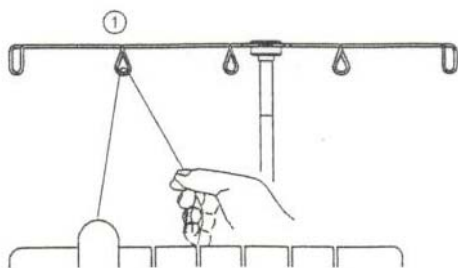
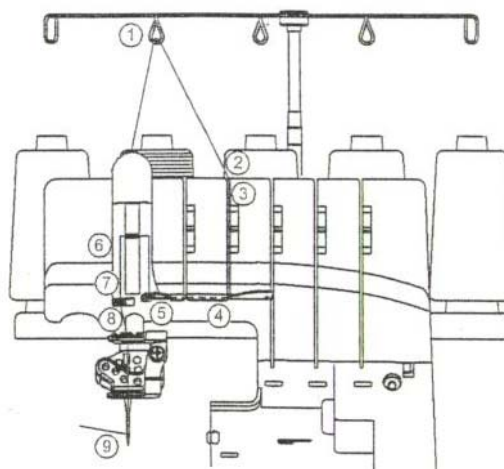

3. Thread the top cover thread guide by pulling the thread towards the left until it slips under the guide. Then pull the thread along the right side of the button as illustrated.

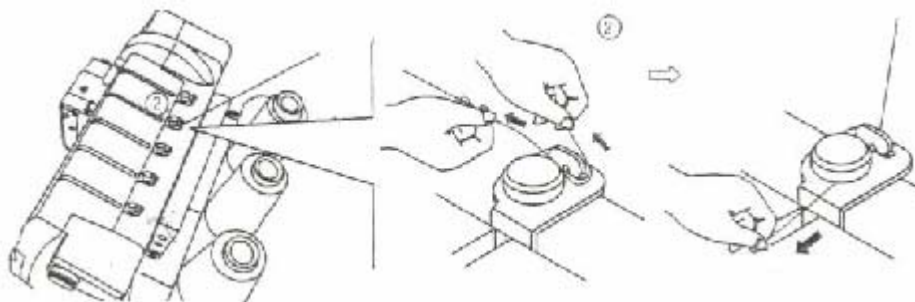

4. While holding the thread, firmly pull the thread between the tension disks.

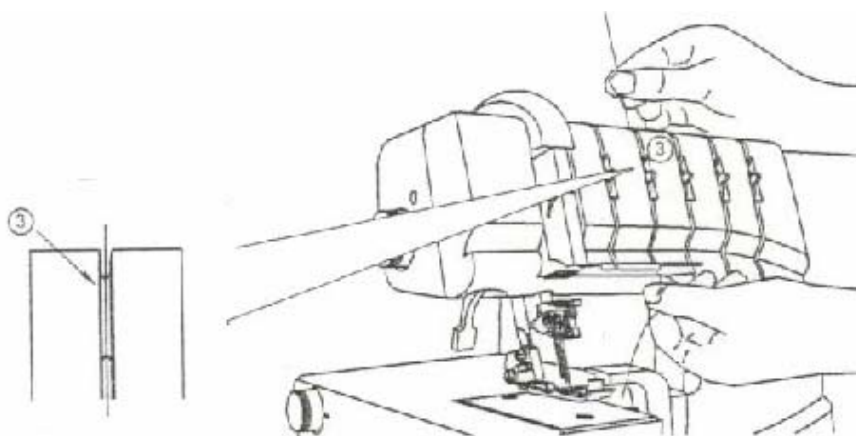

5. Continue to thread points 4-8. Slip the thread into the middle slot of the thread guide ⑤. Go over the take up lever ⑥. Continue by slipping the thread into the middle slot of the thread guides ⑦ and ⑧.
6. Before threading the eye of the needle, make sure the thread is in front of the thread guide located on the bottom of the needle clamp for the Cover Stitch or Chainstitch.

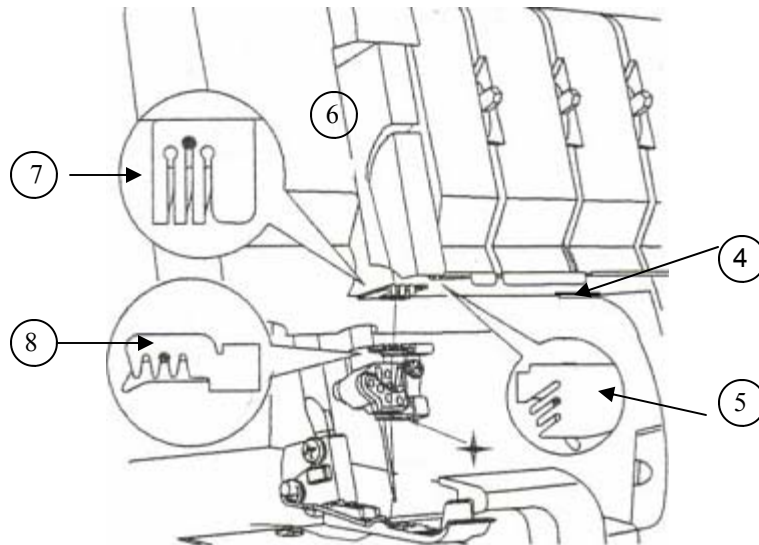

7. Thread the eye of the middle needle ⑨.



8. Draw about 4 inches of the thread through the needle eye towards the back of the machine.
9. Place the thread to the back, under the Presser Foot. Lower foot and sew.

# SINGER®

## Try It:

- ◆ Place two pieces of broadcloth right sides together.
- ◆ Align the fabric so that that the knife just slightly trims the fabric edge.
- ◆ Sew.

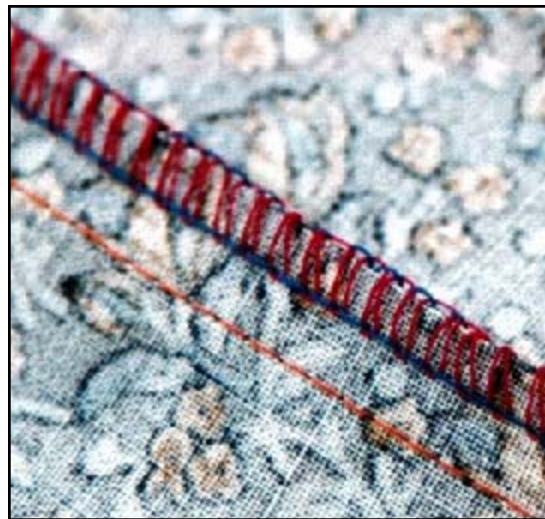
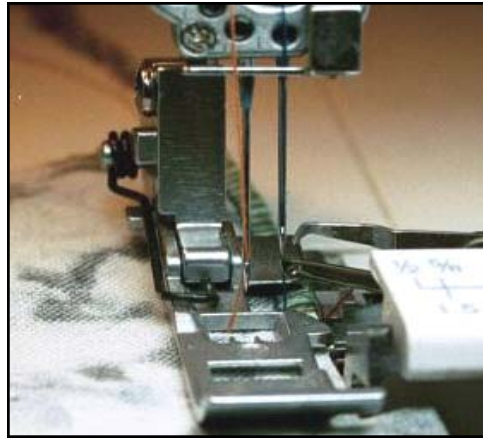

## Five-Thread Safety Stitch (Wide)

This stitch is a combination of a Two-Thread Chainstitch and a Three-Thread Overlock Stitch. It is suitable for woven fabrics and provides a durable seam for heavy weight fabrics such as denim and terrycloth. Using this strong safety stitch eliminates the need to reinforce the seam with a conventional sewing machine straight stitch. The Presser Foot Pressure Adjusting Dial makes it simple to sew on all weights of fabrics. The Five-Thread Safety Stitch can have a width of 2.8mm or 5.6mm, depending on which overlock needle position is chosen.

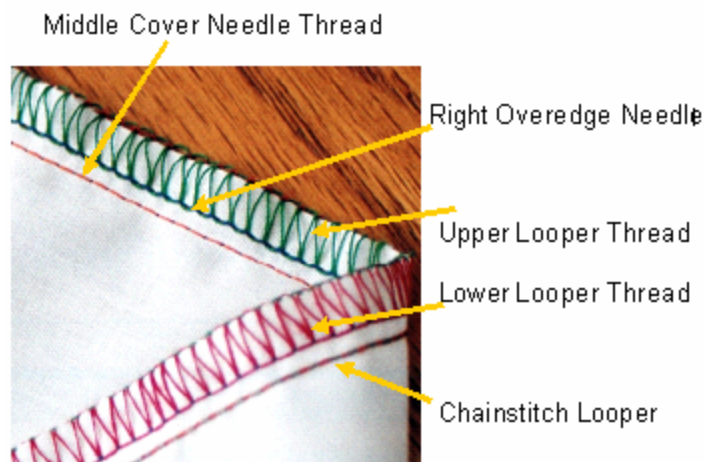
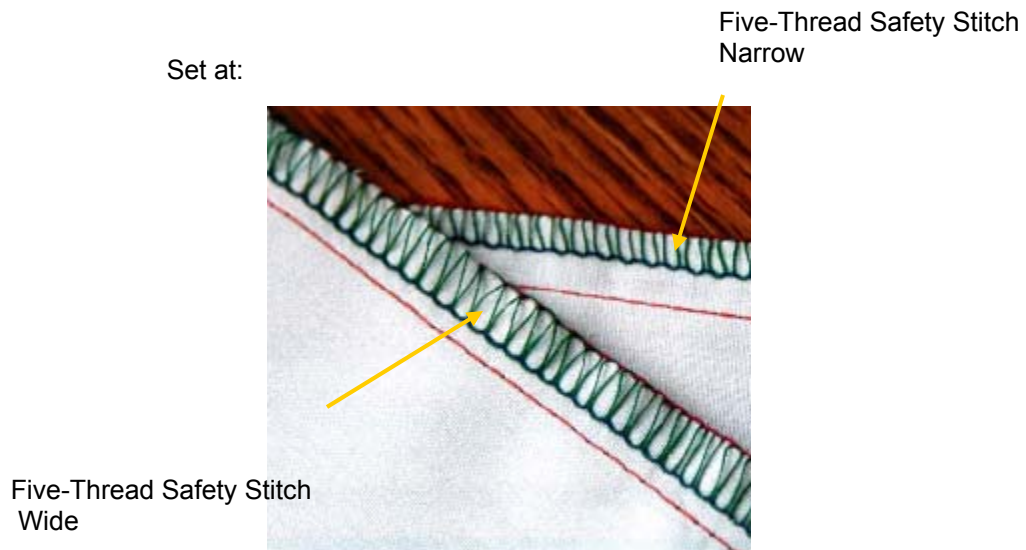

## Set up:

### Needles:

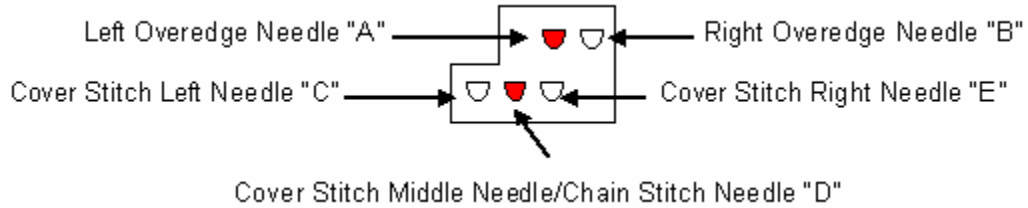

<b>ATD:</b> Auto Tension Dial	"B"
Left Cover Stitch Needle "C"	Not Threaded
Middle Cover Stitch Needle "D" (Orange)	Threaded
Right Cover Stitch Needle "E"	Not Threaded
Overedge Left Needle "A" (Blue)	Threaded
Overedge Right Needle "B"	Not Threaded
Upper Looper (Green)	Looper Engaged and Threaded
Spreader	Not Used
Lower Looper (Red)	Threaded
Chain Stitch Looper (Brown)	Threaded
Upper Looper Clutch	"L"
Upper Knife	Engaged
Seam Guide Plate	Not Installed
Seam Width Dial	"N"
Stitch Length Dial	"N"
Presser Foot Pressure	"N"
Differential Feed Dial	"N"
Stitch Finger	"N"

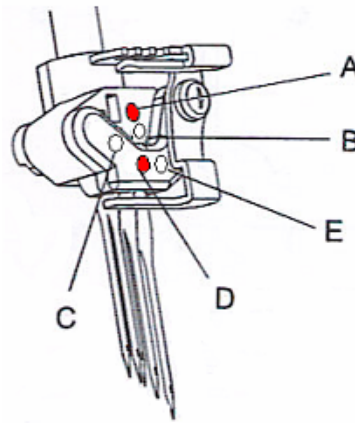

- ◆ Turn Auto Tension Dial to “B”.

- ◆ Turn Stitch Length Dial to “N”.

- ◆ Engage Upper Knife.

The knife will not trim the fabric when it is disengaged.

1. Open Looper Cover.
2. Pull the movable knife holder (silver screw) to the right as far as it will go.
3. Turn the holder clockwise until the knife clicks into a lock position.

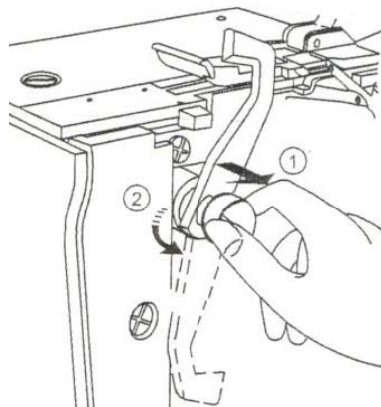
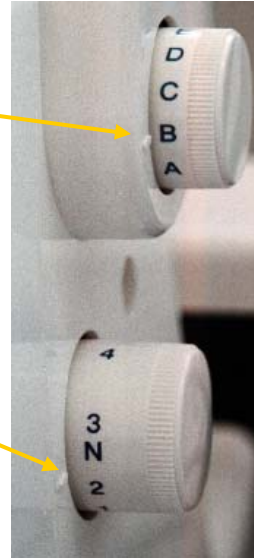

Upper Knife Disengaged



Upper Knife Engaged

# SINGER®

- ◆ Turn Presser Foot Pressure Dial to “N”.



- ◆ Turn Differential Feed Dial to “N”.



- ◆ Turn Seam Width Dial to “N”.

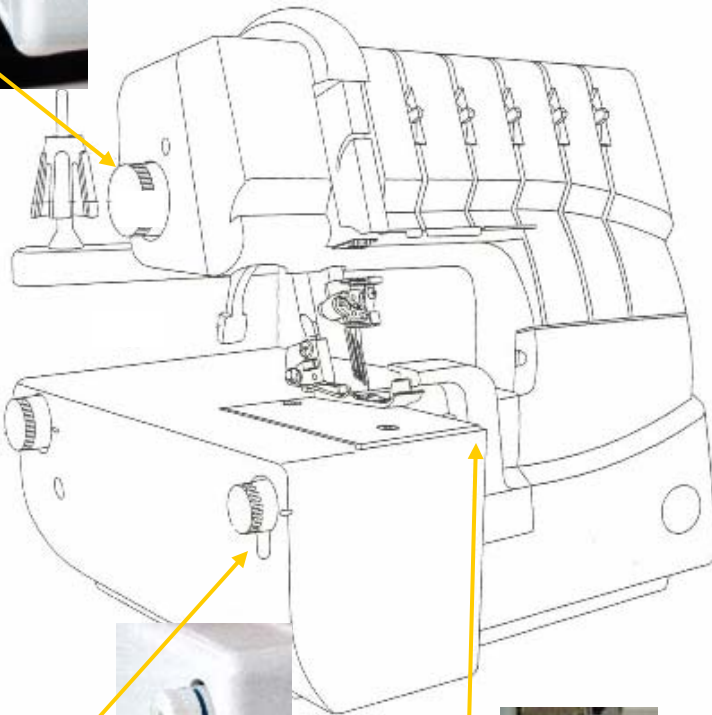

- ◆ Set Stitch Finger to “N”.



# SINGER®

## ◆ Install the Knife Cover.

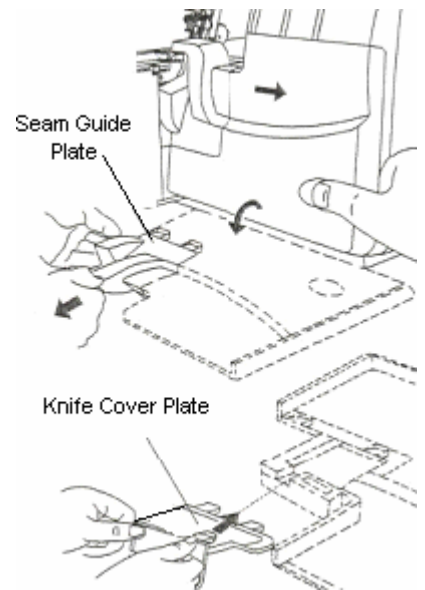

## ◆ Engage Upper Looper. Engaging the Upper Looper causes the looper to move when sewing. Even though the Upper Looper is not threaded, it needs to be engaged.

1. Push the clutch button to the left and down to engage.
2. Turn handwheel.

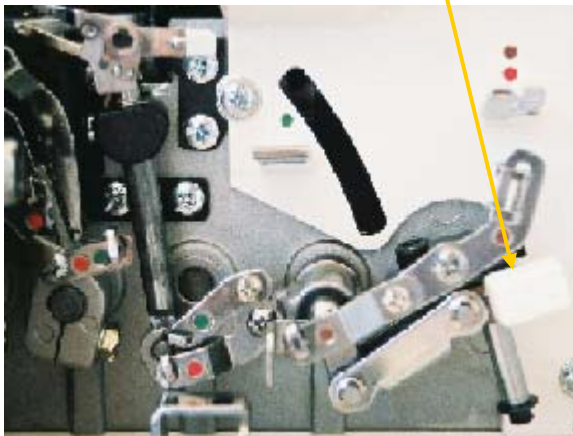
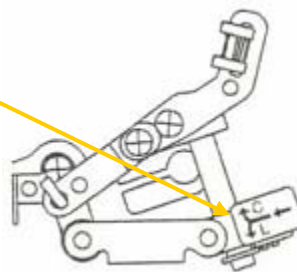

Upper Looper Disengaged

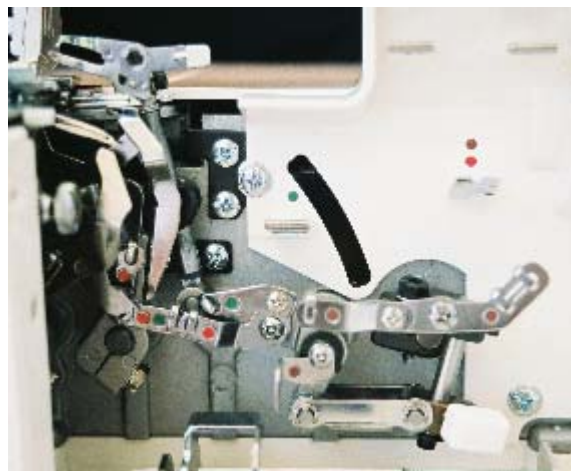

Upper Looper Engaged

- ◆ Disengage Spreader. The Upper Looter has a hole for the thread on the top of the looper. If the stitch requires that the looper be engaged but not threaded, then the Spreader is used. The Spreader simply plugs-in (or closes) the looper's hole. The Spreader is disengaged when the Upper Looter is engaged/operative and threaded. The Spreader is used with a stitch that requires only one looper thread. With the help of the Spreader the single looper thread wraps around the fabric's edge.

1. Lower the white handle on the Spreader to open the eye of the Upper Looter.

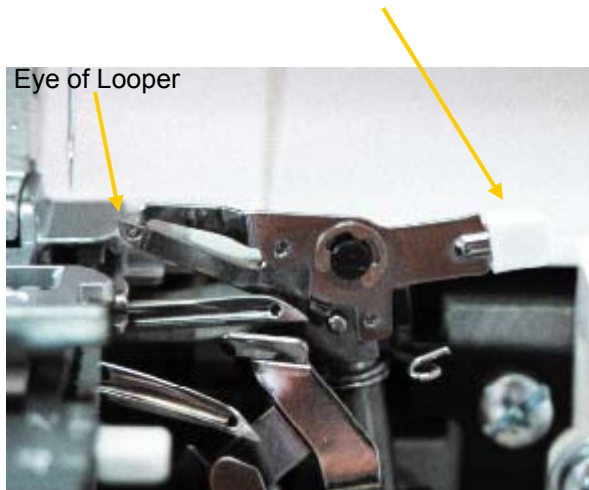

Spreader Engaged



Spreader Disengaged

- ◆ Thread Upper Looter with regular overlock thread.

1. Raise the Presser Foot to release the tension disks. Thread the Lower Looter as illustrated 1-9.

2. Pass thread from back to the front through the thread guide ①.

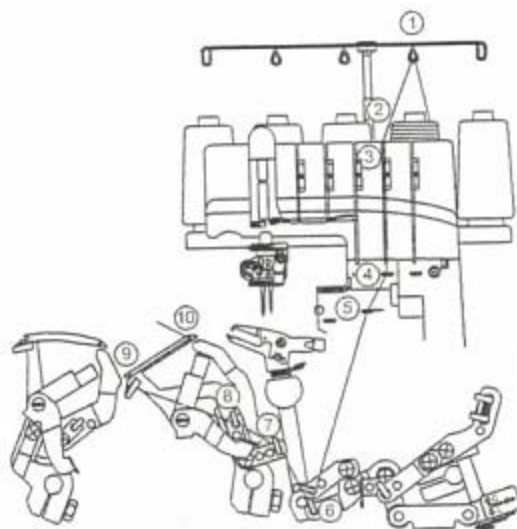
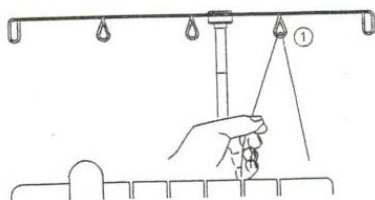

3. Thread the top cover thread guide by pulling the thread towards the left until it slips under the guide. Then pull the thread along the right side of the button as illustrated.

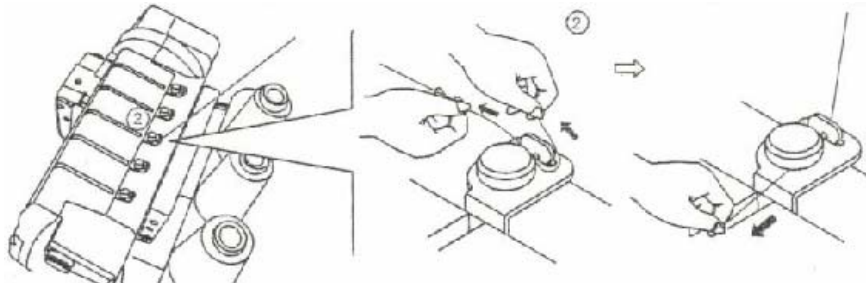

4. While holding the thread, firmly pull the thread between the tension disks.

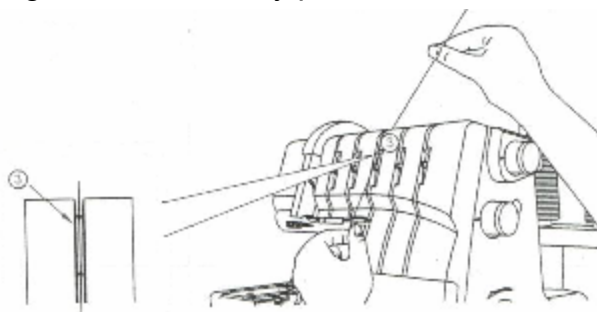

5. Turn the handwheel toward you until the lower looper extends 5-10mm (approximately 1/2 inch) from the needle plate edge.

6. Thread the looper area of the machine following the green color coded thread guides 4-9.

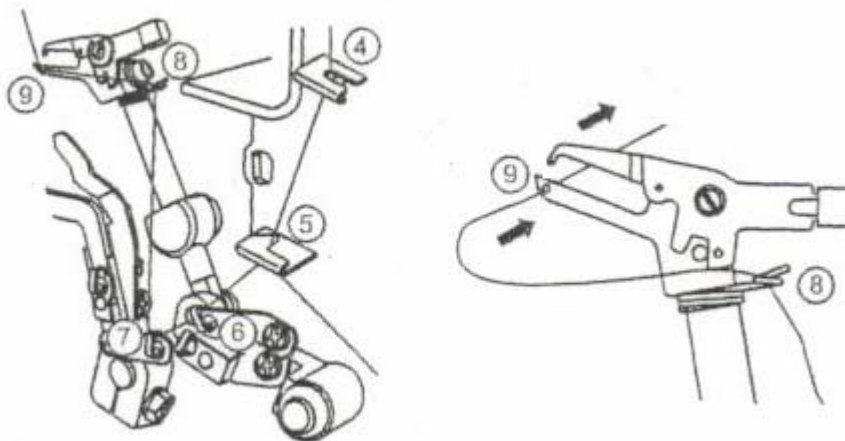

7. Thread the hole in the Upper Looter from front to back ⑨. Pull about 4 inches of thread through the looper and place to the back of the throat plate.

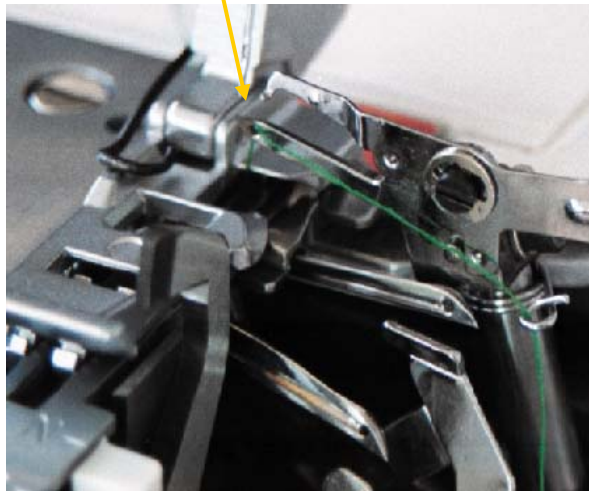

◆ Thread Lower Looter with regular overlock thread.

1. Raise the Presser Foot to release the tension disks. Thread the Lower Looter as illustrated 1-10.
2. Pass thread from back to the front through the thread guide ①.

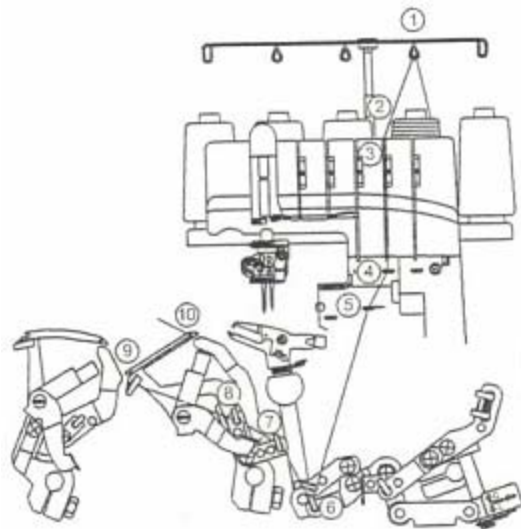
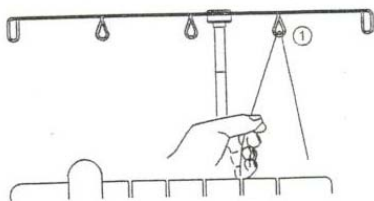

3. Thread the top cover thread guide by pulling the thread towards the left until it slips under the guide. Then pull the thread along the right side of the button as illustrated.

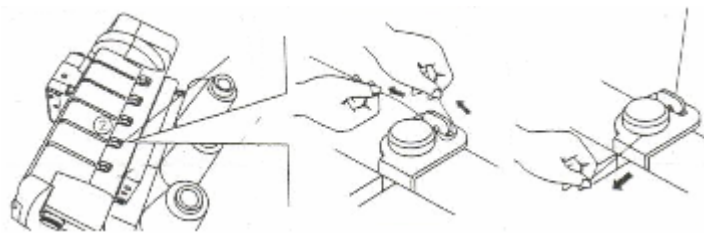

4. While holding the thread, firmly, pull the thread between the tension disks.

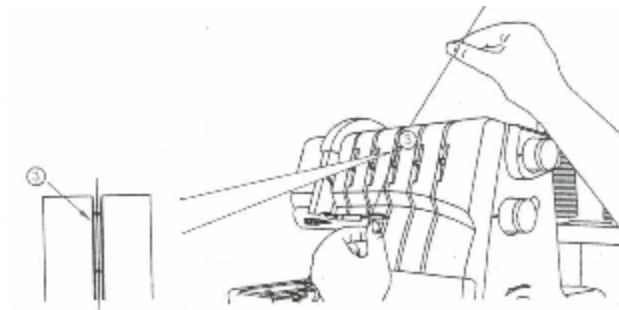

5. Turn the handwheel toward you until the lower looper extends 5-10mm (approximately 1/2 inch) from the needle plate edge.
6. Thread the looper area of the machine following the red color coded thread guides 4-10.

7. Place the thread slightly from left and to the right of threading guide ④.

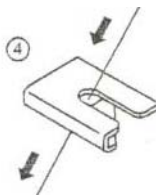

8. Place the thread slightly from the front and to the back of threading guide ⑤.

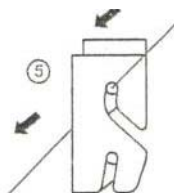

9. Place the thread through ⑥, ⑦ and ⑧.

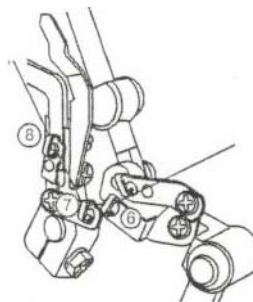

10. Thread the looper eye (A) from front to back. Pull about 4 inches of thread. Position thread into V cutout (B) on threader. Firmly hold thread tail with left hand and pull Threader lever (C) up into place (D).

9

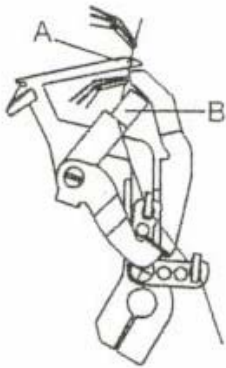

10

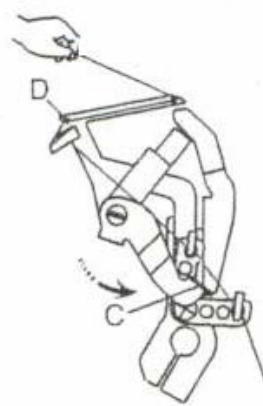

"V" cutout

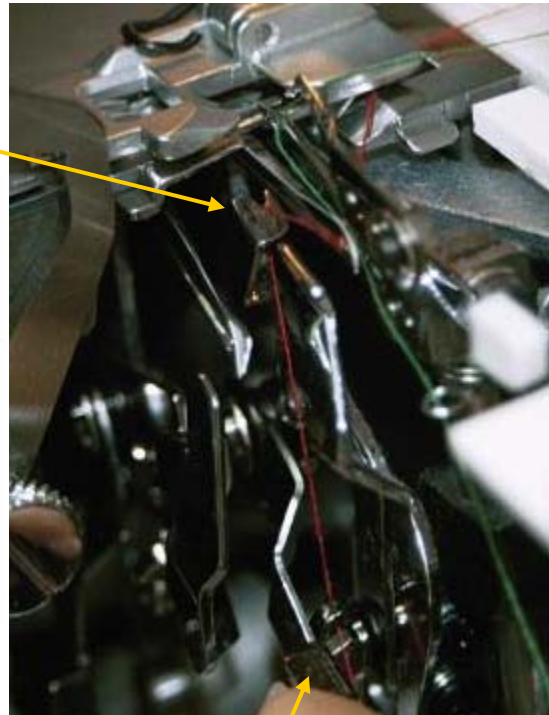

Threader Lever



NOTE: Make sure the Upper Looper thread is behind the Lower Looper thread.

◆ Thread Chainstitch Looper with regular overlock thread.

1. Raise the Presser Foot to release the tension disks. Pass the thread from the back to the front through the thread guide ①.

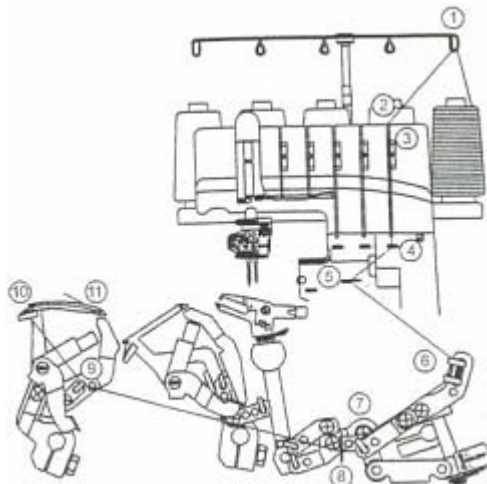
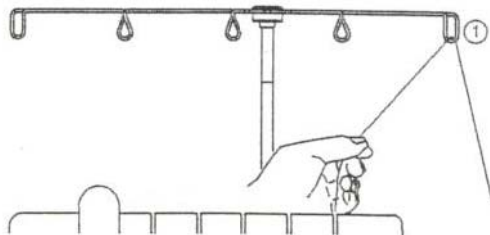

2. Thread the top cover thread guide by pulling the thread towards the left until it slips under the guide. Then pull thread along the right side of the button as illustrated.

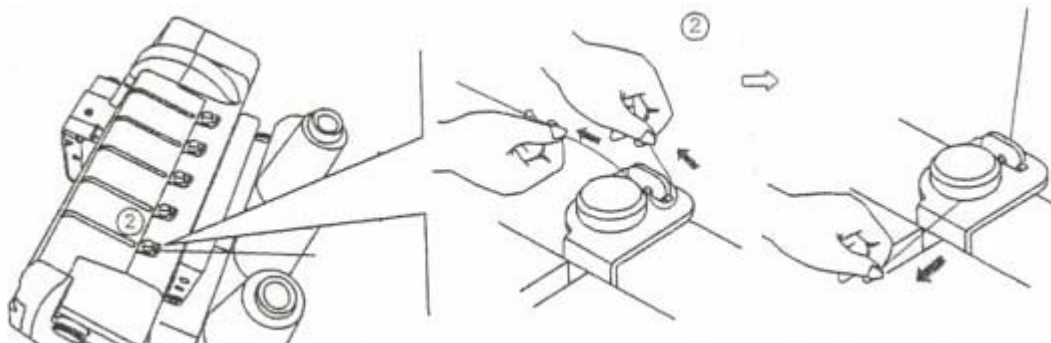

3. While holding the thread, firmly pull the thread between the tension disks.

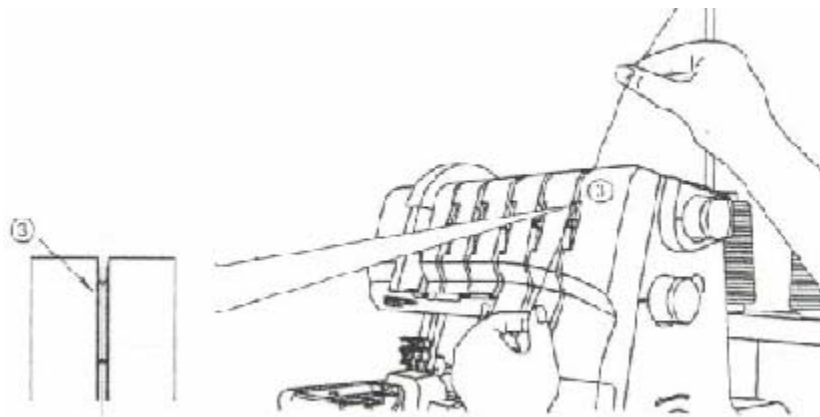

4. Turn the hand wheel toward you until the Chainstitch Looper extends out 10mm (approximately ½ inch) from the needle plate edge.



5. Thread the looper area of the machine following the brown color-coded thread guides 4-11. Use the tweezers provided in the accessory case to aid in threading the looper.

6. Place the thread through threading guides ④ and ⑤.

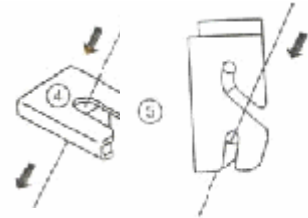

7. Continue threading guides ⑥, ⑦, ⑧ and ⑨.

8. Thread the looper eye (A) from front to back. Pull about 4 inches of thread through the looper. Position the thread into the V cutout (B) on the threader. Firmly hold the thread tail with left hand and pull threader lever (C) up into place (D). Gently pull 5-6" of thread to the back of the machine.

⑩

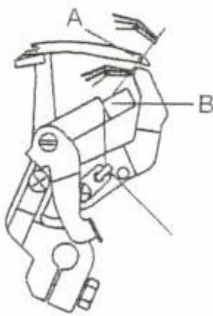

⑪

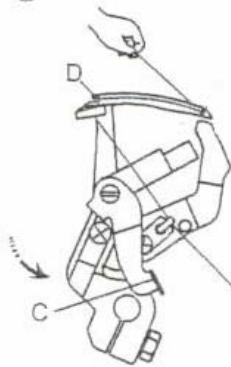

"V" cutout

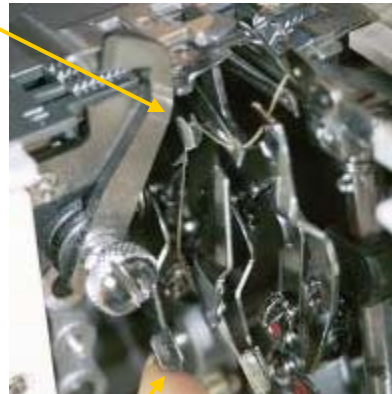

Threader Lever



◆ Thread Left Overlock needle with regular thread.

1. Raise the Presser Foot to release the tension disks. Thread the left needle as illustrated 1-9.

2. Pass thread from back to the front through the thread guide ①.

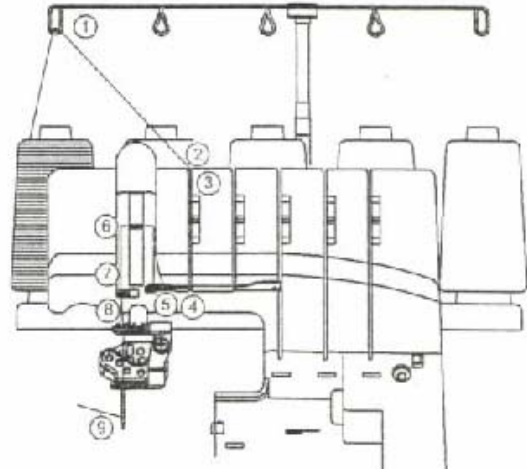
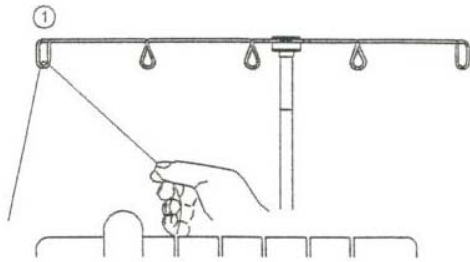

3. Thread the top cover thread guide by pulling the thread towards the left until it slips under the guide. Then pull the thread along the right side of the button as illustrated.

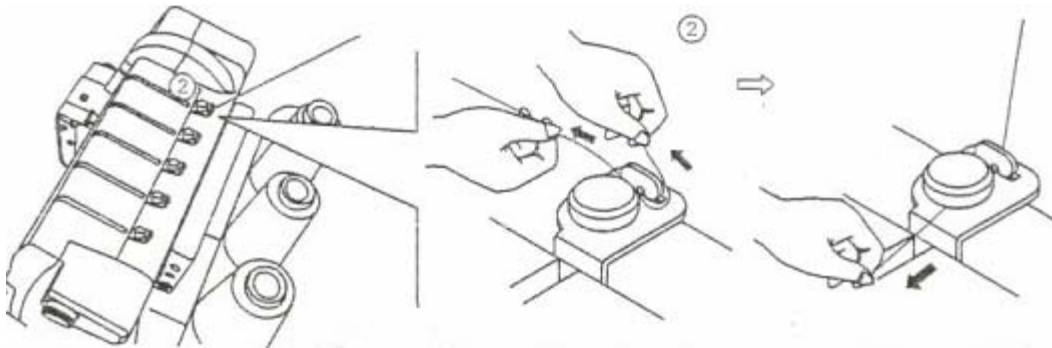

4. While holding the thread firmly, pull the thread between the tension disks.

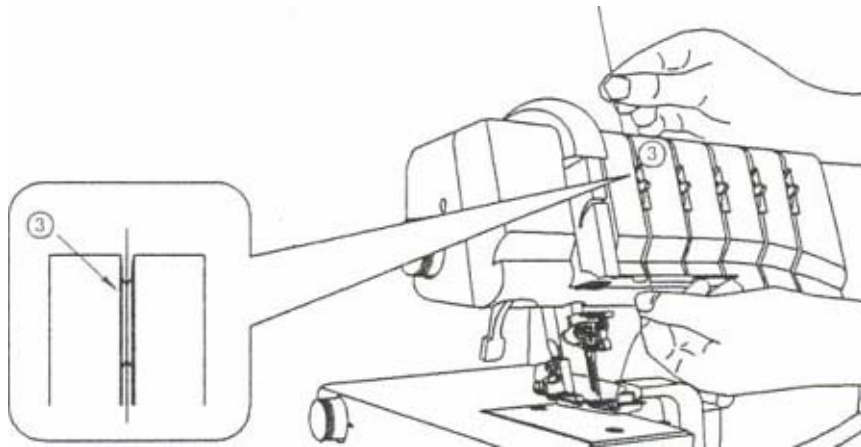

5. Continue to thread points 4-8. Slip the thread into the forward slot of the thread guide ⑤. Go over the take up lever ⑥. Continue by slipping the thread into the left slot of the thread guides ⑦ and ⑧.
6. Before threading the eye of the needle, make sure the thread is behind the thread guide located on the bottom of the needle clamp.

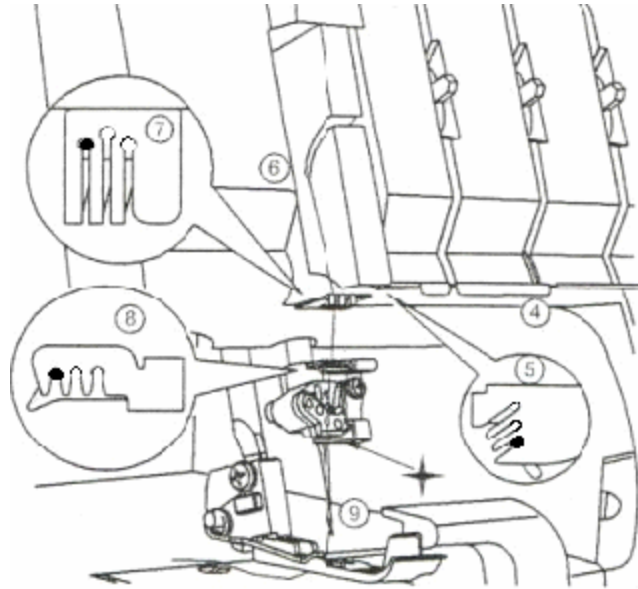

7. Thread the eye of the Left Overedge Needle ⑨.



8. Draw about 4 inches of the thread through the needle eye towards the back of the machine.
9. Place the thread to the back, under the Presser Foot. Lower foot and sew.

◆ Thread Middle Cover stitch needle with regular overlock thread.

1. Raise the Presser Foot to release the tension disks. Thread the Cover Stitch Middle/Chain Stitch needle as illustrated 1-9.
2. Pass thread from back to the front through the thread guide ①.

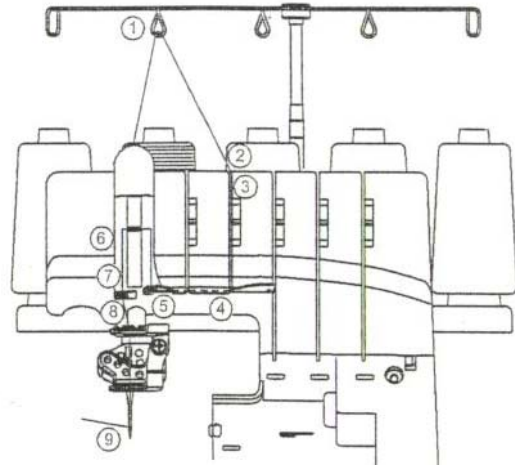
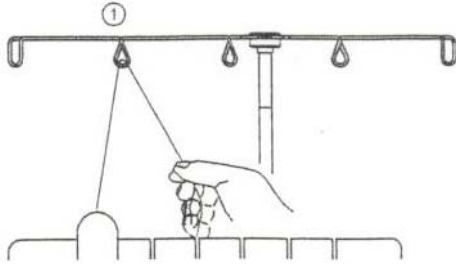

3. Thread the top cover thread guide by pulling the thread towards the left until it slips under the guide. Then pull the thread along the right side of the button as illustrated.

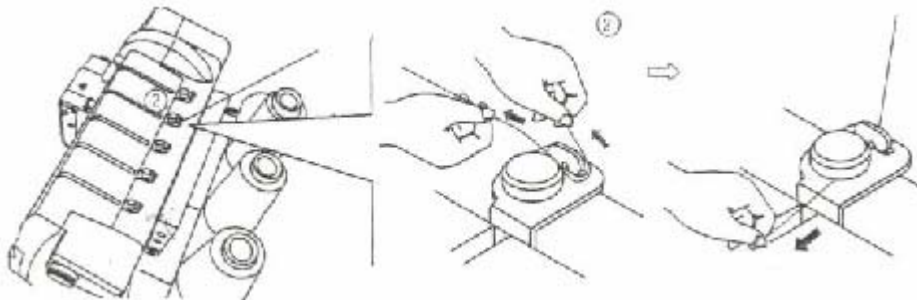

4. While holding the thread firmly, pull the thread between the tension disks.

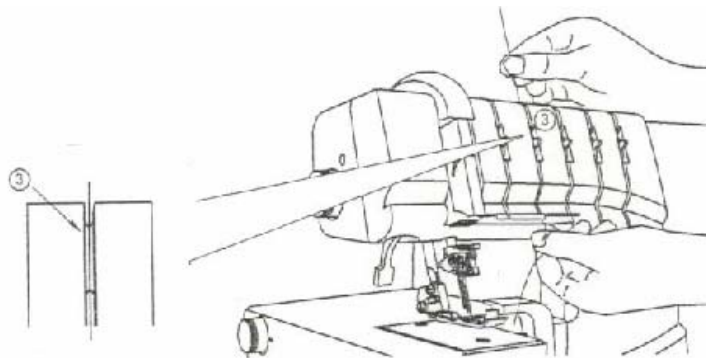

5. Continue to thread points 4-8. Slip the thread into the middle slot of the thread guide ⑤. Go over the take up lever ⑥. Continue by slipping the thread into the middle slot of the thread guides ⑦ and ⑧.

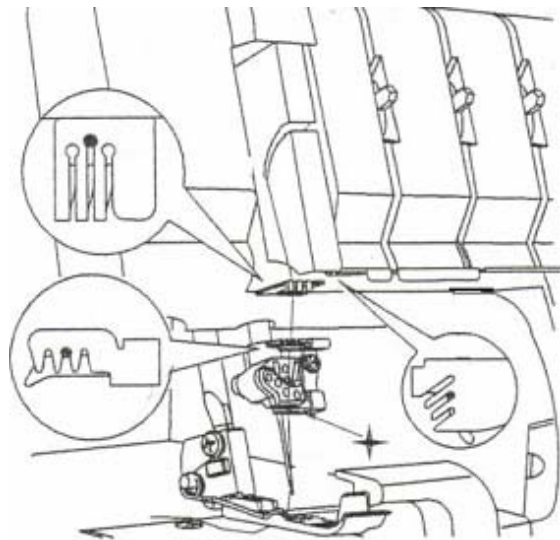

6. Before threading the eye of the needle, make sure the thread is in front of the thread guide located on the bottom of the needle clamp for the Cover Stitch or Chainstitch.

7. Thread the eye of the middle needle ⑨.

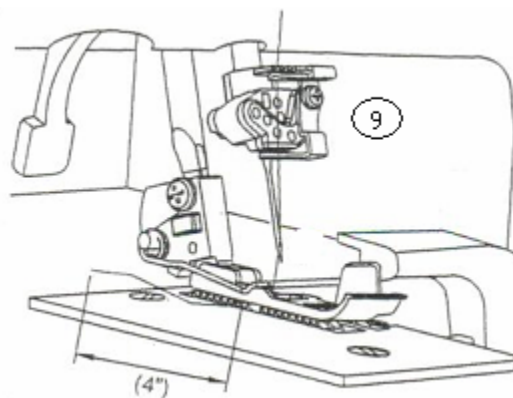

8. Draw about 4 inches of the thread through the needle eye, under the Presser Foot and then towards the back of the machine.
9. Place the thread to the back, under the Presser Foot. Lower foot and sew.

# SINGER®

## Try It:

- ◆ Place two pieces of home decorative fabric, right sides together.
- ◆ Align the fabric so that the knife just slightly trims the fabric edge.
- ◆ Sew.



## Five-Thread Safety Stitch (Narrow)

This stitch is a combination of a Two-Thread Chainstitch and a Three-Thread Overlock Stitch. It is suitable for woven fabrics and provides a durable seam for heavy weight fabrics such as denim and terrycloth. Using this strong and stable safety stitch eliminates the need to reinforce the seam with a conventional sewing machine straight stitch. The Pressure Adjusting Dial makes it simple to sew on all weights of fabrics. The Five-Thread Safety Stitch can have a width of 2.8mm or 5.6mm depending on which overlock needle position is chosen.



Hint: Try a wider stitch width (6.5) for thicker fabrics such as Terrycloth.

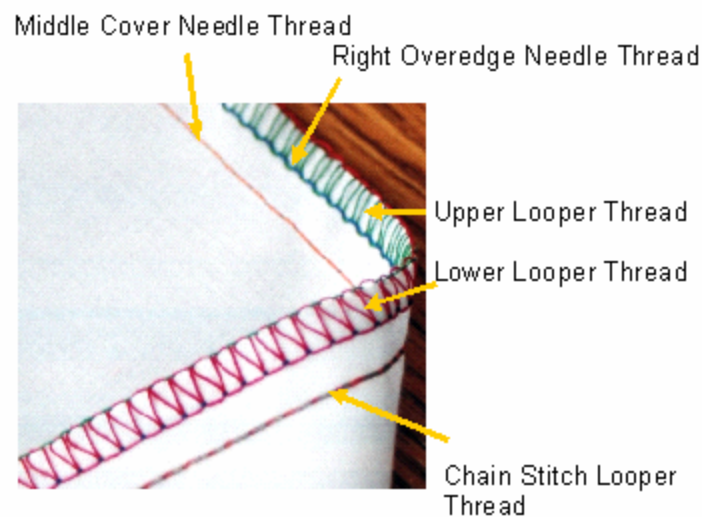

## Set up:

### Needles:

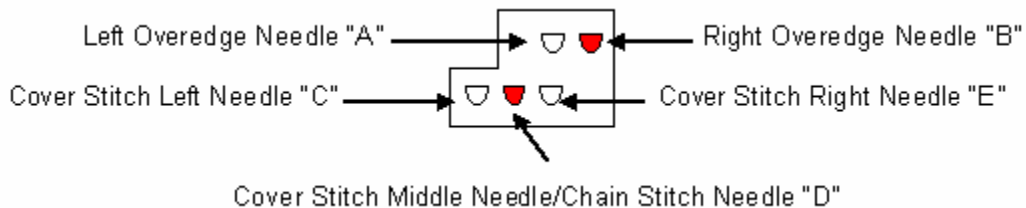

### Set at:

<b>ATD:</b> Auto Tension Dial	"A"
Left Cover Stitch Needle "C"	Not Threaded
Middle Cover Stitch Needle "D" (Orange)	Threaded
Right Cover Stitch Needle "E"	Not Threaded
Overedge Left Needle "A"	Not Threaded
Overedge Right Needle "B" (Blue)	Threaded
Upper Looper (Green)	Looper Engaged and Threaded
Spreader	Disengaged
Lower Looper (Red)	Threaded
Chain Stitch Looper (Brown)	Threaded
Upper Looper Clutch	"L"
Upper Knife	Engaged
Seam Guide Plate	Not Installed Use Knife Cover
Seam Width Dial	"N"
Stitch Length Dial	"N"
Presser Foot Pressure	"N"
Differential Feed Dial	"N"
Stitch Finger	"N"

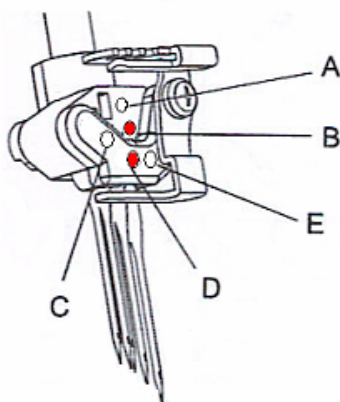

- ◆ Turn Auto Tension Dial to “A”.

- ◆ Turn Stitch Length Dial to “N”.

- ◆ Engage Upper Knife.

The knife will not trim the fabric when it is disengaged.

1. Open Looper Cover.
2. Pull the movable knife holder (silver screw) to the right as far as it will go.
3. Turn the holder clockwise until the knife clicks into a lock position.

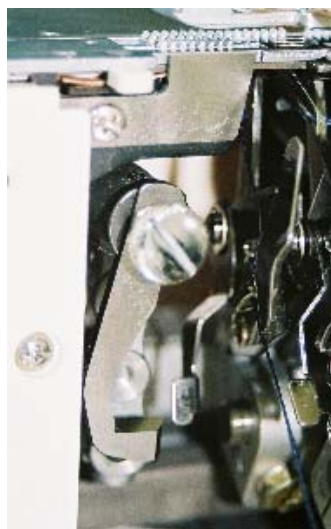
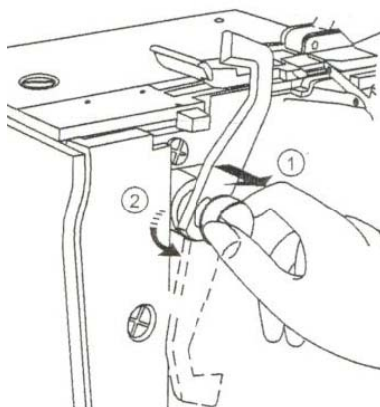

Upper Knife Disengaged



Upper Knife Engaged



# SINGER®

- ◆ Turn Presser Foot Pressure dial to “N”.



- ◆ Turn Differential Feed Dial to “N”.



- ◆ Turn Seam Width Dial to “N”.

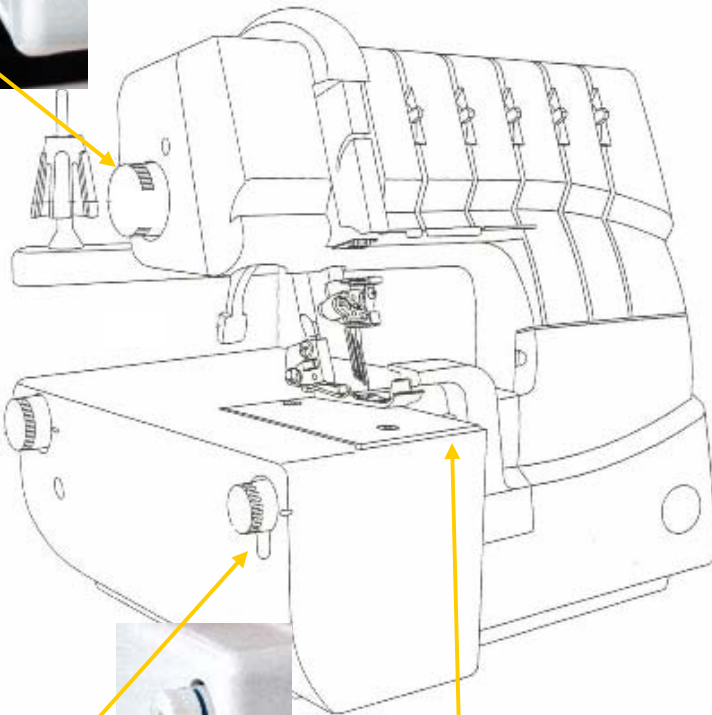

- ◆ Set Stitch Finger to “N”.

# SINGER®

## ◆ Install the Knife Cover.

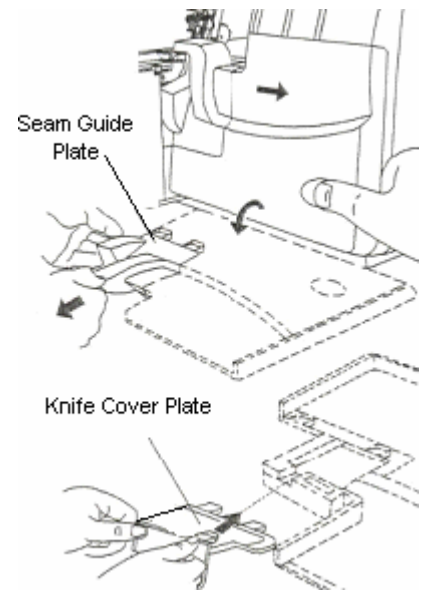

## ◆ Engage Upper Looper. Engaging the Upper Looper causes the looper to move when sewing. Even though the Upper Looper is not threaded it needs to be engaged.

1. Push the clutch button to the left and down to engage.
2. Turn handwheel.

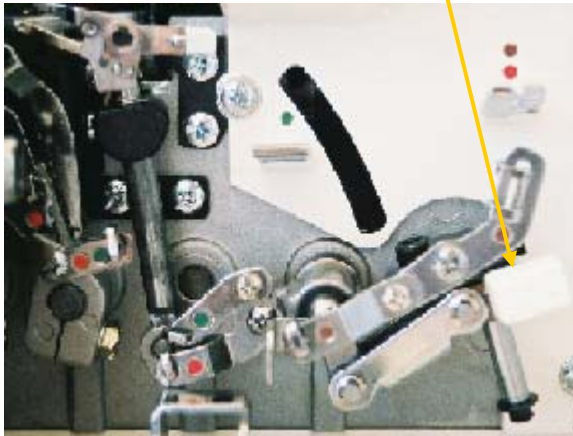
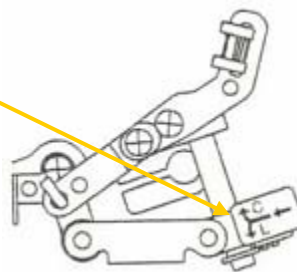

Upper Looper Disengaged

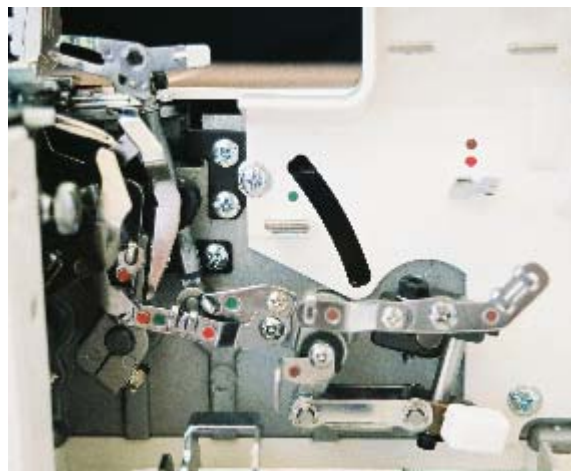

Upper Looper Engaged

- ◆ Disengage Spreader. The Upper Loper has a hole for the thread on the top of the looper. If the stitch requires that the looper be engaged, but not threaded then the Spreader is used. The Spreader simply plugs-in (or closes) the looper's hole. The Spreader is disengaged when the Upper Loper is engaged/operative and threaded. The Spreader is usually used with a stitch that requires only one looper thread. With the help of the Spreader the single looper thread wraps around the fabric's edge.

1. Lower the white handle on the Spreader to open the eye of the Upper Loper.

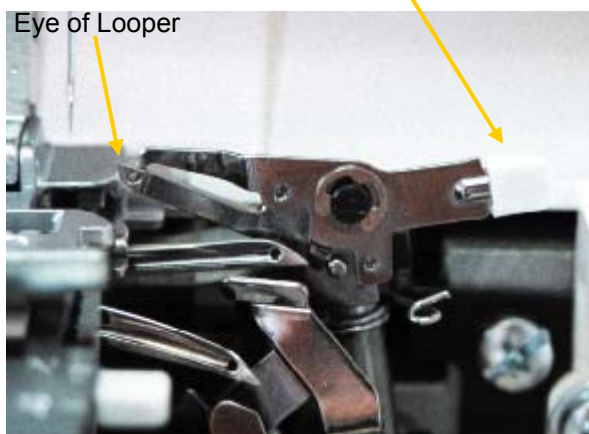

Spreader Engaged



Spreader Disengaged

- ◆ Thread Upper Loper with regular overlock thread.

1. Raise the Presser Foot to release the tension disks. Thread the Lower Loper as illustrated 1-9.

2. Pass thread from back to the front through the thread guide ①.

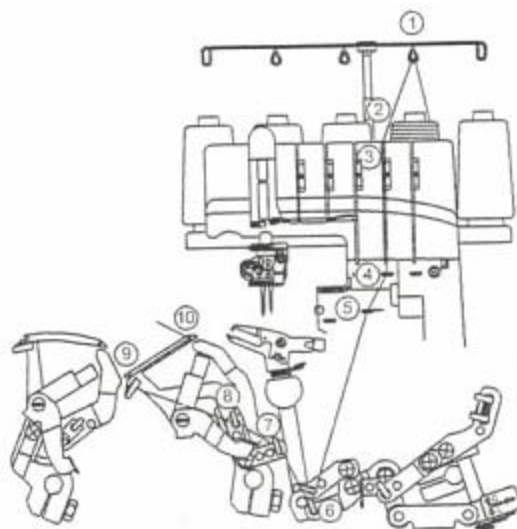
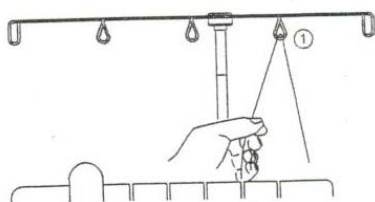

3. Thread the top cover thread guide by pulling the thread towards the left until it slips under the guide. Then pull the thread along the right side of the button as illustrated.

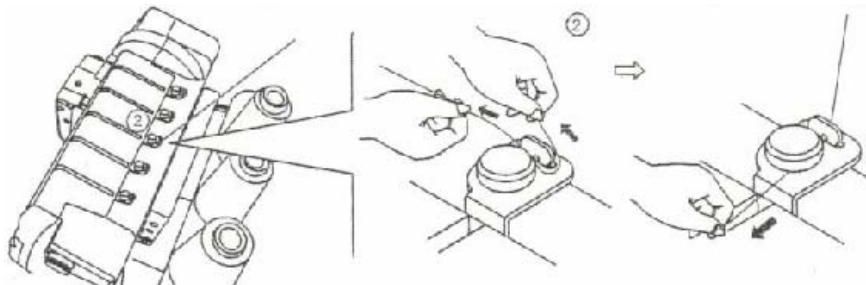

4. While holding the thread firmly, pull the thread between the tension disks.

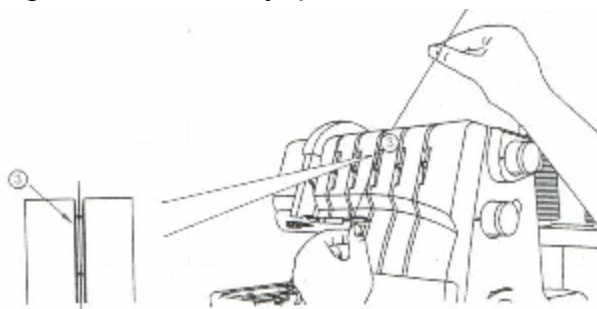

5. Turn the handwheel toward you until the lower looper extends 5-10mm (approximately 1/2 inch) from the needle plate edge.

6. Thread the looper area of the machine following the green color coded thread guides 4-9.

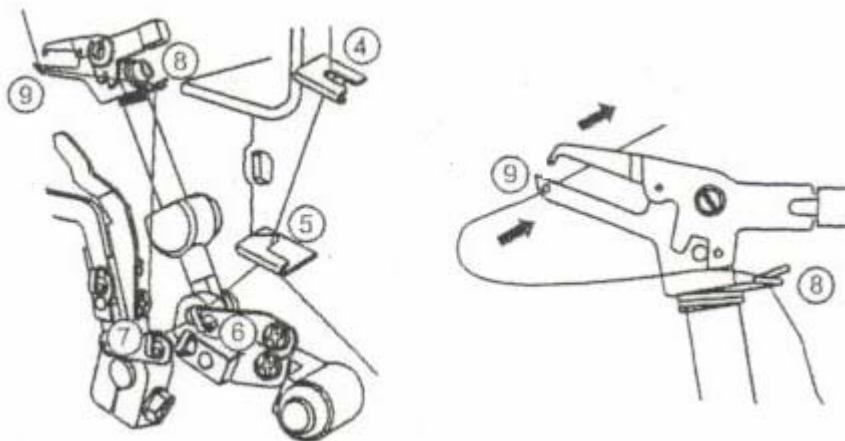

7. Thread the hole in the Upper Looter from front to back ⑨. Pull about 4 inches of thread through the looper and place to the back of the throat plate.

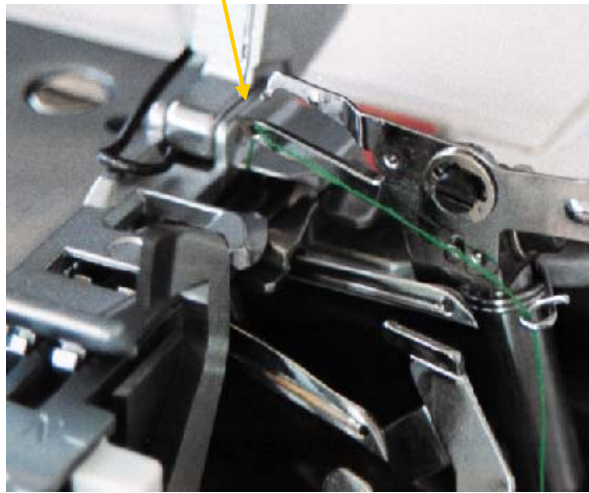

◆ Thread Lower Looter with regular overlock thread.

1. Raise the Presser Foot to release the Tension disks. Thread the Lower Looter as illustrated 1-10.

2. Pass thread from back to the front through the thread guide ①.

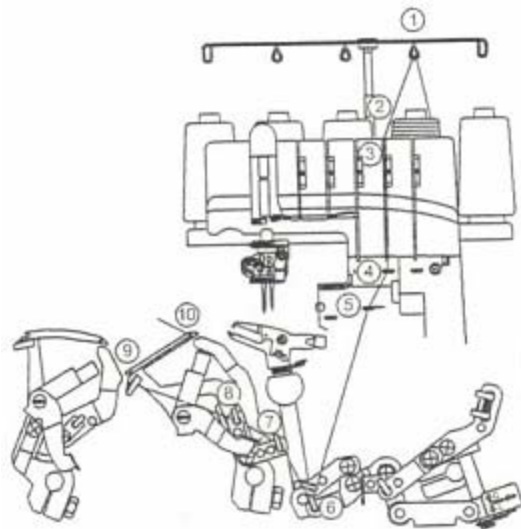
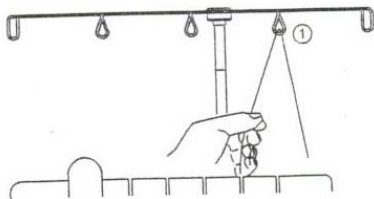

3. Thread the top cover thread guide by pulling the thread towards the left until it slips under the guide. Then pull the thread along the right side of the button as illustrated.

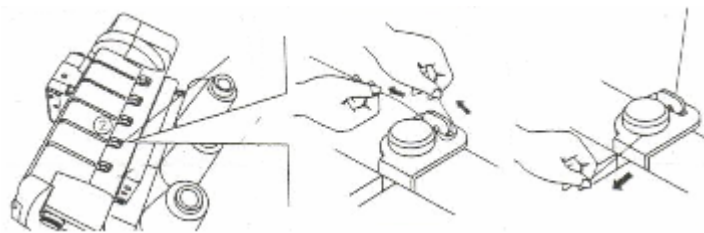

4. While holding the thread firmly, pull the thread between the tension disks.

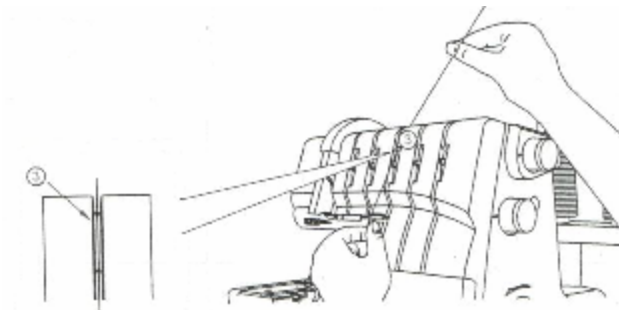

5. Turn the handwheel toward you until the lower looper extends 5-10mm (approximately 1/2 inch) from the needle plate edge.
6. Thread the looper area of the machine following the red color coded thread guides 4-10.

7. Place the thread slightly from left and to the right of threading guide ④.

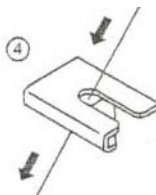

8. Place the thread slightly from the front and to the back of threading guide ⑤.

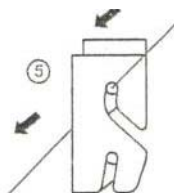

9. Place the thread through ⑥, ⑦ and ⑧.

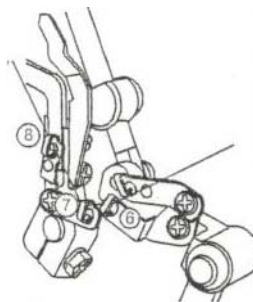

10. Thread the looper eye (A) from front to back. Pull about 4 inches of thread. Position thread into V cutout (B) on threader. Firmly hold thread tail with left hand and pull Threader lever (C) up into place (D).

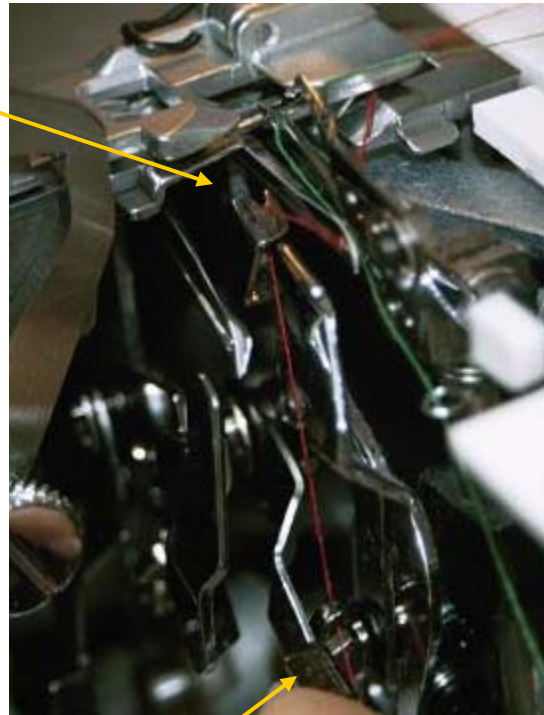
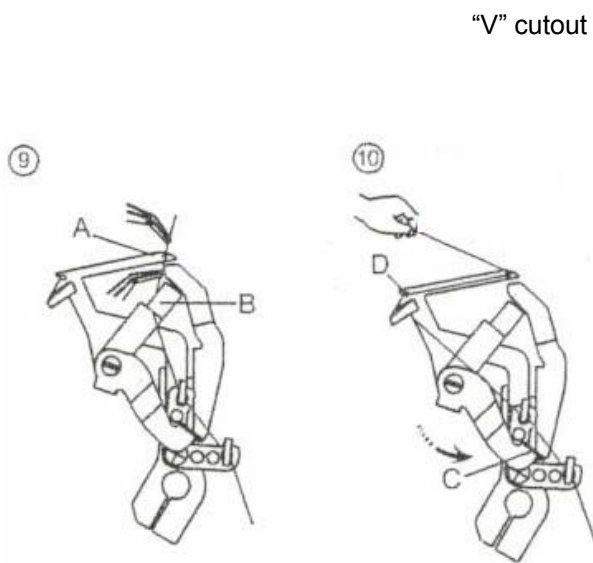

Threader Lever



NOTE: Make sure the Upper Looper thread is behind the Lower Looper thread.

◆ Thread Chainstitch Looper with regular overlock thread.

1. Raise the Presser Foot to release the tension disks. Pass the thread from the back to the front through the thread guide ①.

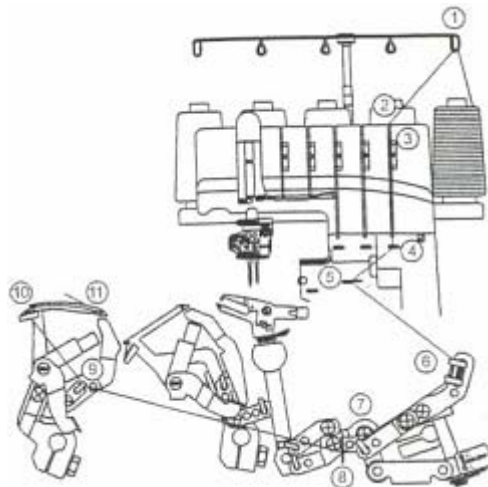
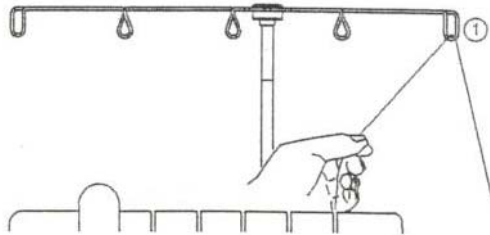

2. Thread the top cover thread guide by pulling the thread towards the left until it slips under the guide. Then pull thread along the right side of the button as illustrated.

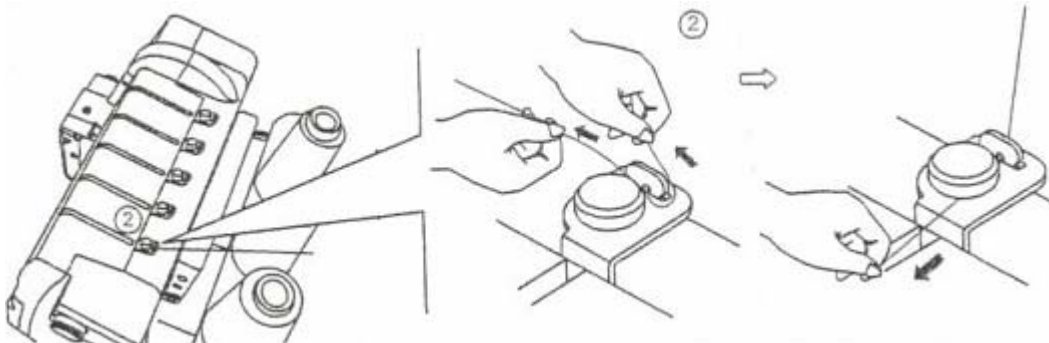

3. While holding the thread firmly, pull the thread between the tension disks.

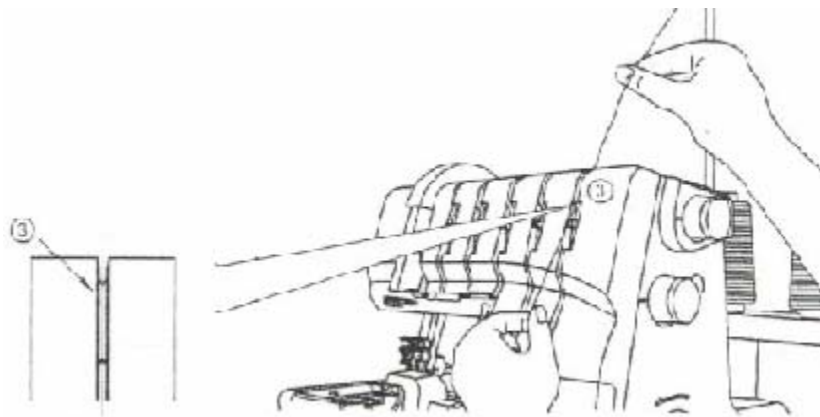



4. Turn the hand wheel toward you until the Chainstitch Looper extends out 10mm (approximately ½ inch) from the needle plate edge.

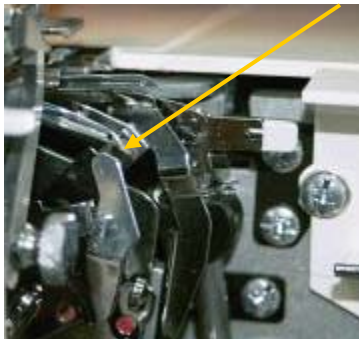

5. Thread the looper area of the machine following the brown color-coded thread guides 4-11. Use the tweezers provided in the accessory case to aid in threading the looper.

6. Place the thread through threading guide ④ and ⑤.

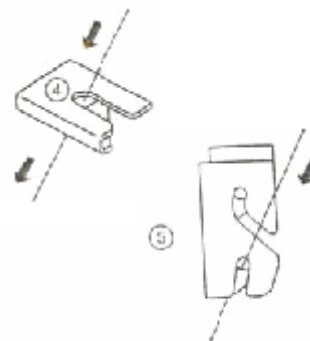

7. Continue threading guides ⑥, ⑦, ⑧ and ⑨.

8. Thread the looper eye (A) from front to back. Pull about 4 inches of thread through the looper. Position the thread into the V cutout (B) on the threader. Firmly hold the thread tail with your left hand and pull threader lever (C) up into place (D). Gently pull 5-6" of thread to the back of the machine.

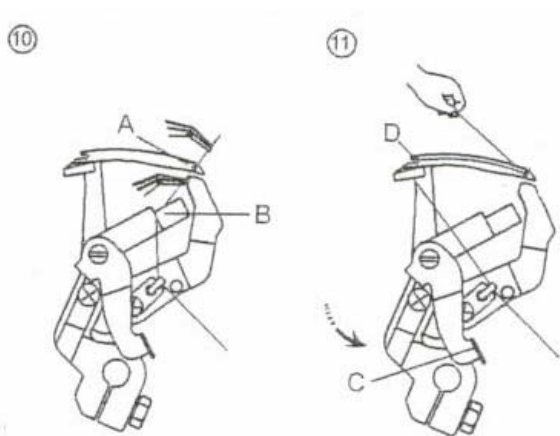

"V" cutout

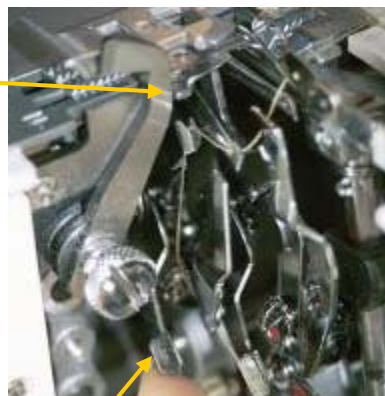

Threader lever

◆ Thread Right Overedge needle with regular overlock thread.

1. Raise the Presser Foot to release the tension disks. Thread the right needle as illustrated 1-9.

2. Pass thread from back to the front through the thread guide ①.

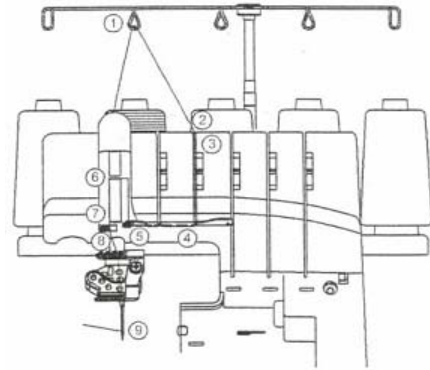
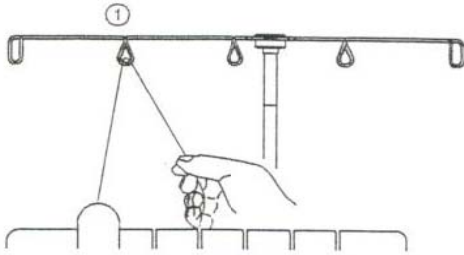

3. Thread the top cover thread guide by pulling the thread towards the left until it slips under the guide. Then pull the thread along the right side of the button as illustrated.

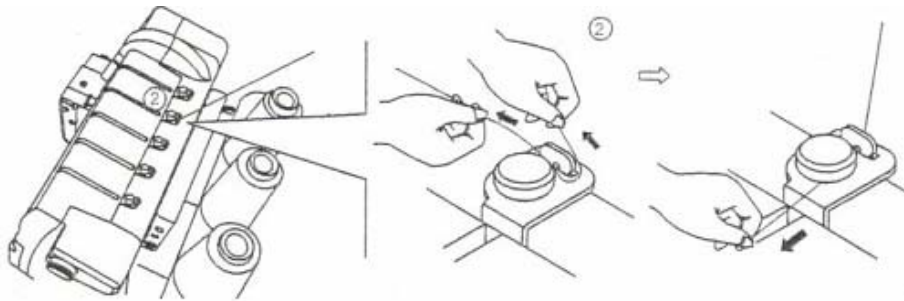

4. Continue to thread points 4-8. Slip the thread into the rear slot of the thread guide ⑤. Go over the take up lever ⑥. Continue by slipping the thread into the right slot of the thread guides ⑦ and ⑧.

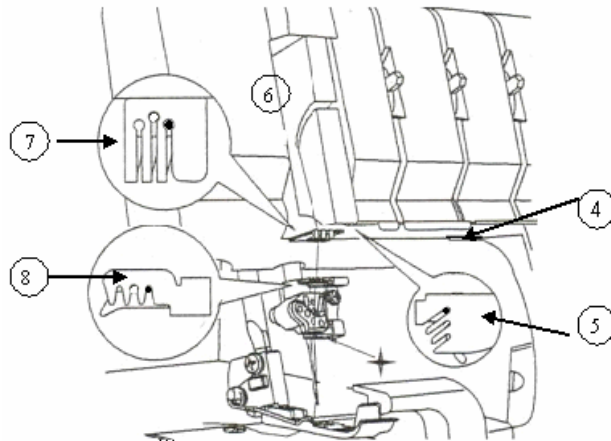

5. Before threading the eye of the needle, make sure the thread is behind the thread guide located on the bottom of the needle clamp.

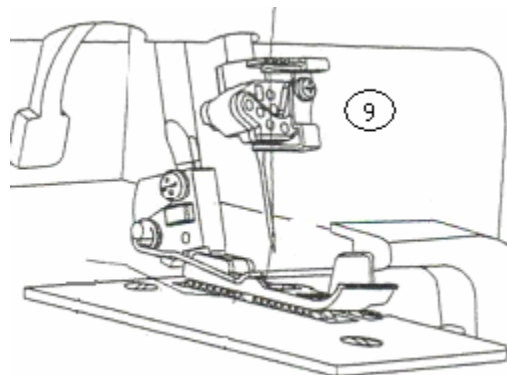

6. Thread the eye of the Right Overedge Needle ⑨.

◆ Thread Middle Cover stitch needle with regular overlock thread.

1. Raise the Presser Foot to release the tension disks. Thread the Cover Stitch Middle/Chain Stitch needle as illustrated 1-9.
2. Pass thread from back to the front through the thread guide ①.

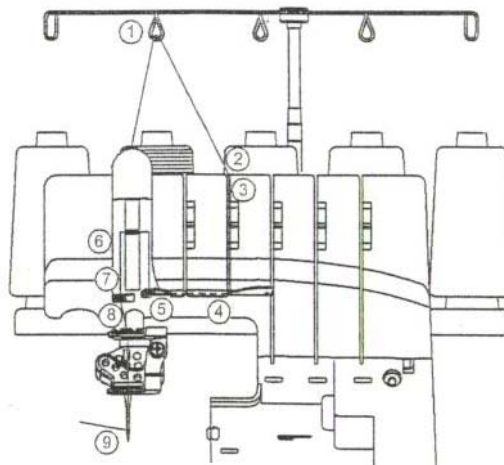

3. Thread the top cover thread guide by pulling the thread towards the left until it slips under the guide. Then pull the thread along the right side of the button as illustrated.

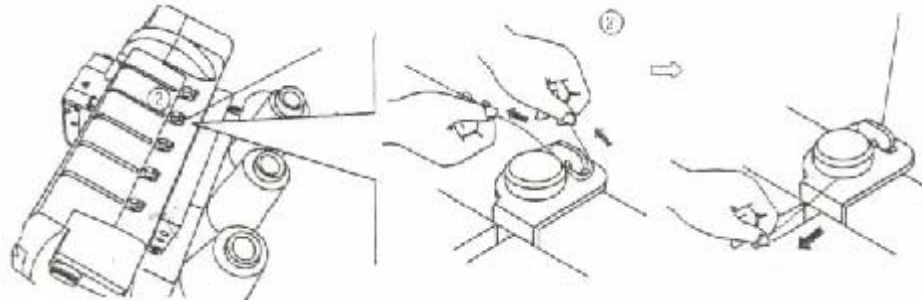

4. While holding the thread firmly, pull the thread between the tension disks.

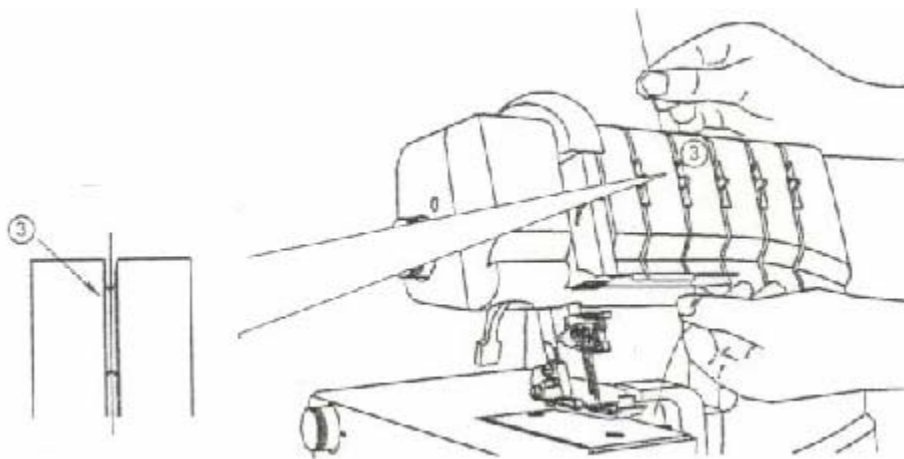

5. Continue to thread points 4-8. Slip the thread into the middle slot of the thread guide ⑤. Go over the take up lever ⑥. Continue by slipping the thread into the middle slot of the thread guides ⑦ and ⑧.

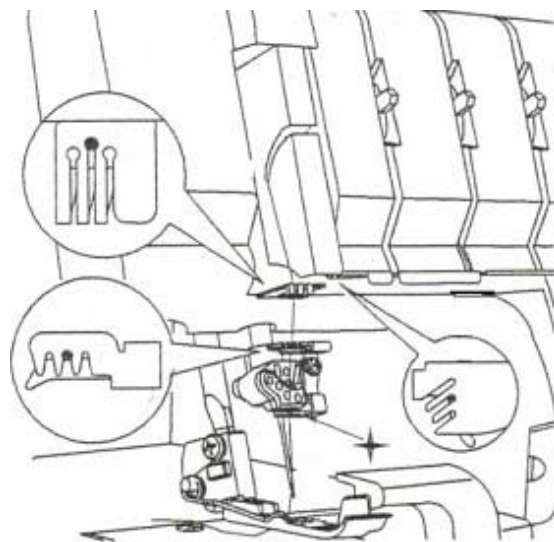

6. Before threading the eye of the needle, make sure the thread is in front of the thread guide located on the bottom of the needle clamp for the Cover Stitch or Chainstitch.
7. Thread the eye of the middle needle ⑨.

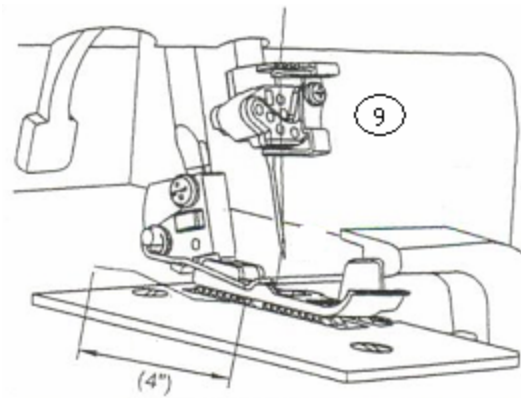
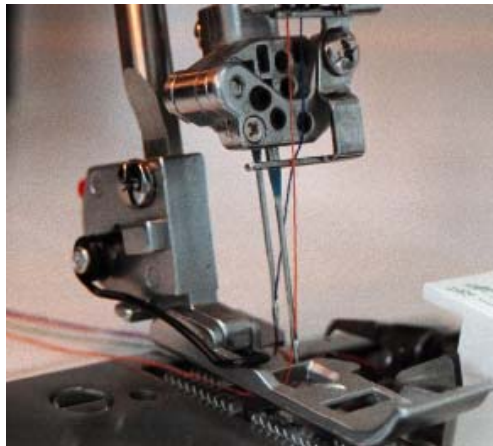

8. Draw about 4 inches of the thread through the needle eye towards the back of the machine.
9. Place the thread to the back, under the Presser Foot. Lower foot and sew.

# SINGER®

## Try It:

- ◆ Place two pieces of terrycloth right sides together.
- ◆ Align the fabric so that that the knife just slightly trims the fabric edge.
- ◆ Sew.



## Cover Stitch Narrow

This professional Cover Hem stitch is a necessary requirement for today's sewing. The stitch is often seen in ready-to-wear garments. Two needles create parallel rows of topstitching and one looper sews an edge finish on the underneath side. Depending on which needle position is selected, the width can be 5.6mm wide or 2.8mm wide.

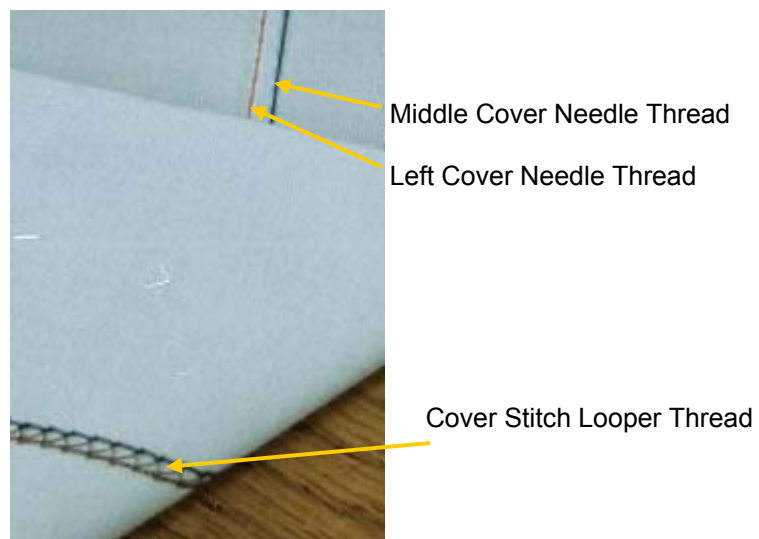

## Set up:

### Needles:

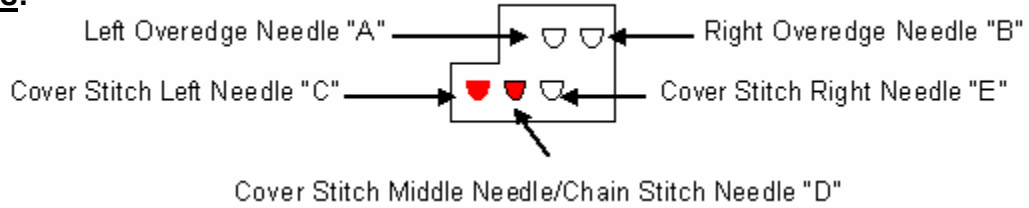

### Set-up:

<b>ATD:</b> Auto Tension Dial	"K"
Left Cover Stitch Needle "C" (Orange)	Threaded
Middle Cover Stitch Needle "D" (Blue)	Threaded
Right Cover Stitch "E" Needle	Not Threaded
Overedge Left "A" Needle	Not Threaded
Overedge Right "B" Needle	Not Threaded
Upper Looper (Green)	Looper Disengaged and Not Threaded
Spreader	Not Used
Lower Looper	Not Threaded
Chain Stitch Looper (Brown)	Threaded
Upper Looper Clutch	"C"
Upper Knife	Non-working Position
Seam Guide Plate	Installed
Seam Width Dial	"N"
Stitch Length Dial	"N"
Presser Foot Pressure	"N"
Differential Feed Dial	"N"
Stitch Finger	"R"

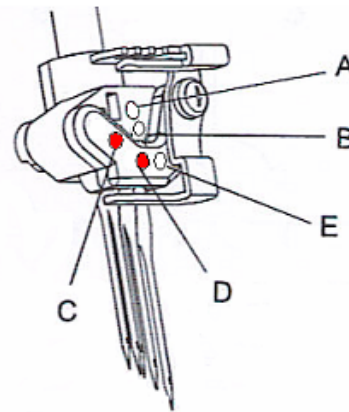



## Cover Stitch Narrow

- ◆ Turn Auto Tension Dial to “K”.

- ◆ Turn Stitch Length Dial to “2.5”.

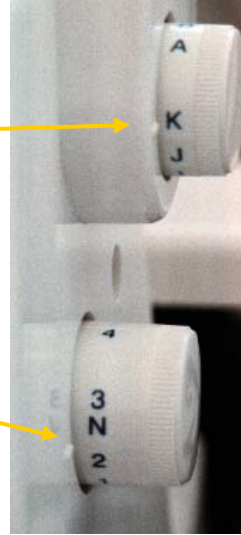

- ◆ Disengage Upper Knife. The knife will not trim the fabric when it is disengaged.
  1. Open Loper Cover.
  2. Pull the movable knife holder (silver screw) to the right as far as it will go.
  3. Turn the holder counter clockwise until the knife clicks into a lock position.

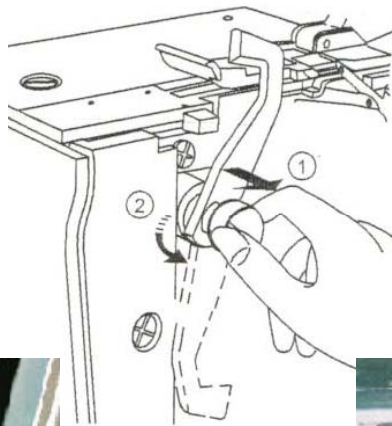

Upper Knife Engaged



Upper Knife Disengaged

# SINGER®

- ◆ Turn Presser Foot Pressure Dial to “N”.



- ◆ Turn Differential Feed Dial to “N”.



- ◆ Turn Seam Width Dial to “N”.



- ◆ Set Stitch Finger to “R”.

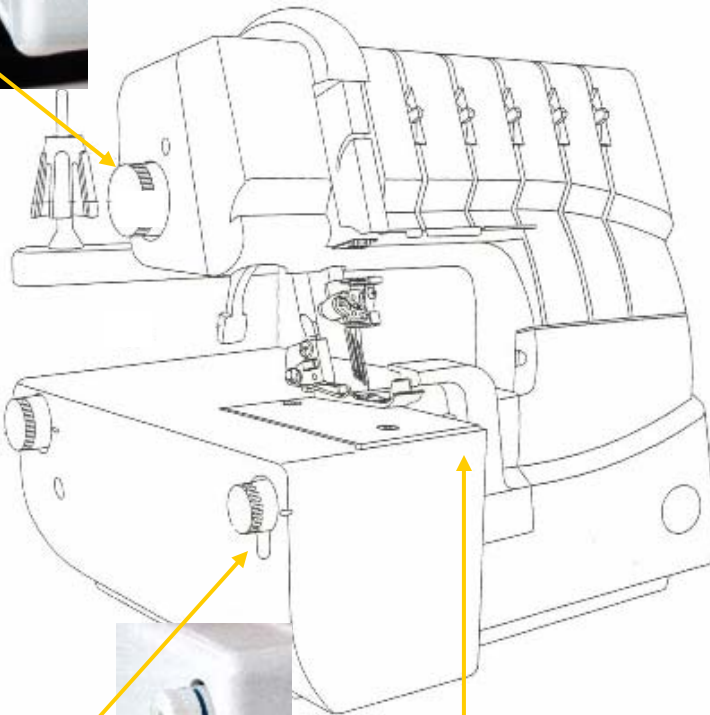

# SINGER®

- ◆ Install the Seam Guide Plate. The Seam Guide Plate provides a flat surface for the fabric and seam guides. It can only be used when the knife and the lower looper are disengaged. The Seam Guide Plate is used when sewing the Chainstitch, Cover Stitch and the Triple Cover Stitch.

1. Open looper cover.
2. Remove Knife Cover by pulling it toward you.
3. Slide the Seam Guide Plate into place.

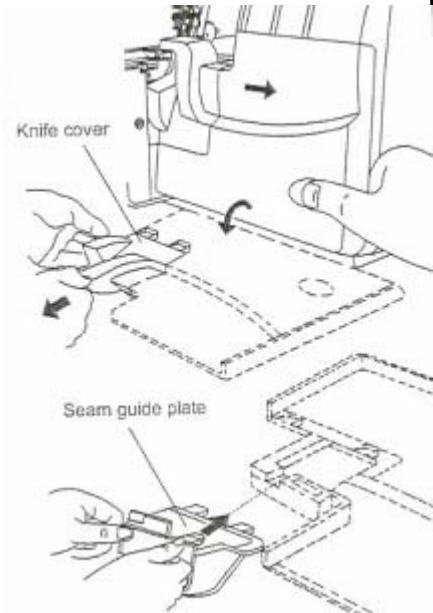

- ◆ Disengage Upper Looper. By disengaging the Upper Looper, the looper no longer moves when sewing. It is nonoperative. If the looper was still engaged it would hit the Seam Guide Plate.

1. Turn handwheel until the Upper Looper is in the lowest position.
2. Push the clutch button to the left and up to disengage.

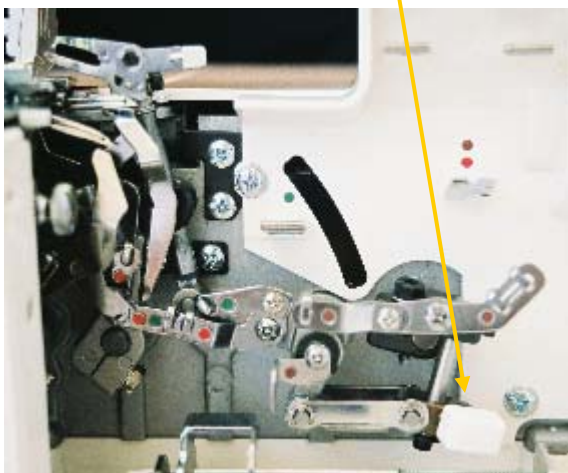

Upper Looper Engaged

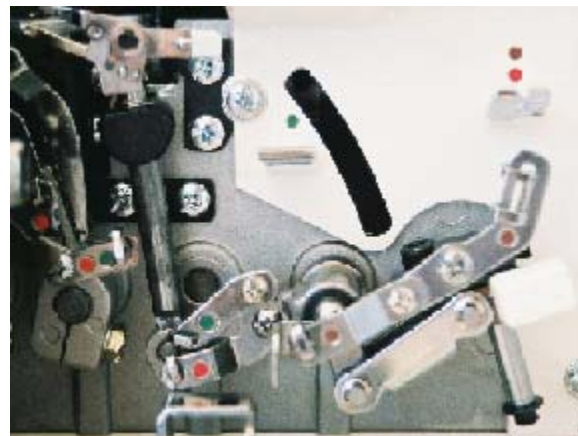
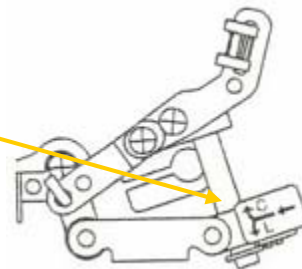

Upper Looper Disengaged

◆ Thread Chainstitch Looper with a regular overlock thread.

1. Raise the Presser Foot to release the tension disks. Pass the thread from the back to the front through the thread guide ①.

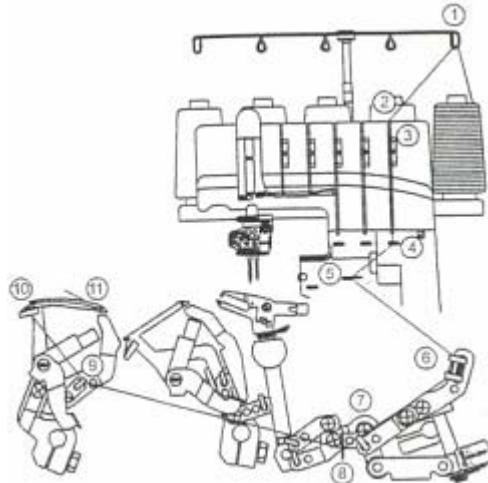
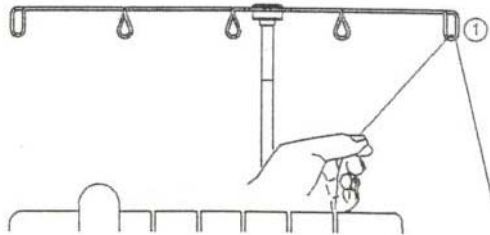

2. Thread the top cover thread guide by pulling the thread towards the left until it slips under the guide. Then pull thread along the right side of the button as illustrated.

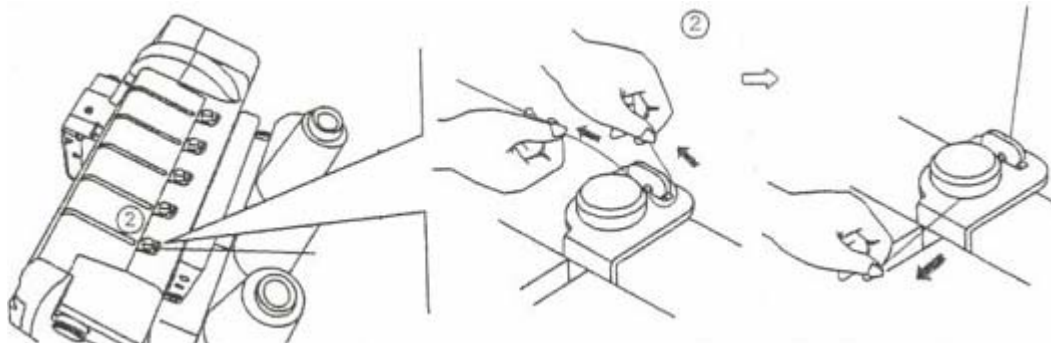

3. While holding the thread firmly, pull the thread between the tension disks.

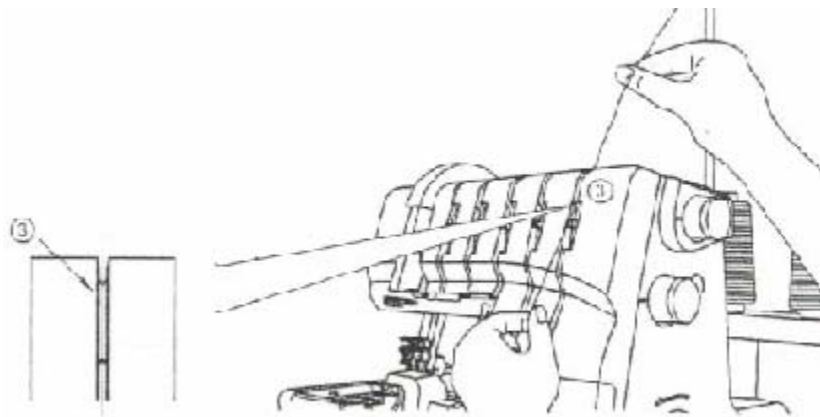

4. Turn the hand wheel toward you until the Chainstitch Looper extends out 10mm (approximately ½ inch) from the needle plate edge.

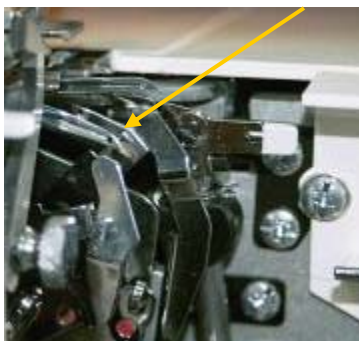

5. Thread the looper area of the machine following the brown color-coded thread guides 4-11. Use the tweezers provided in the accessory case to aid in threading the looper.

6. Place the thread through threading guides ④ and ⑤.

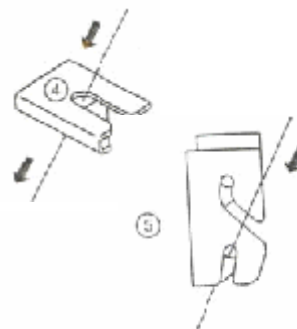

7. Continue threading guides ⑥, ⑦, ⑧ and ⑨.

8. Thread the looper eye (A) from front to back. Pull about 4 inches of thread through the looper. Position the thread into the V cutout (B) on the threader. Firmly hold the thread tail with your left hand and pull threader lever (C) up into place (D). Gently pull 5-6" of thread to the back of the machine.

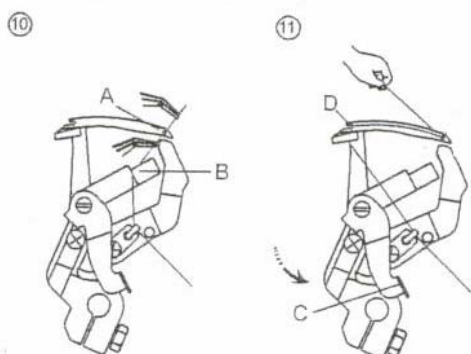

"V" cutout

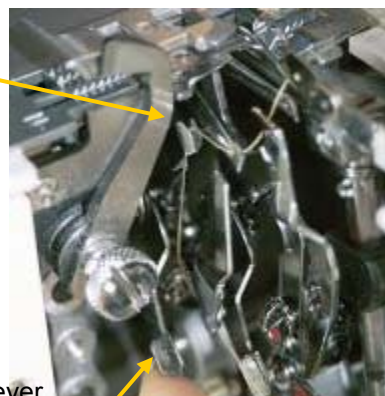

Threader Lever

◆ Thread Middle Cover needle with regular overlock thread.

1. Raise the Presser Foot to release the tension disks. Thread the Cover Stitch Middle/Chain Stitch needle as illustrated 1-9.
2. Pass thread from back to the front through the thread guide ①.

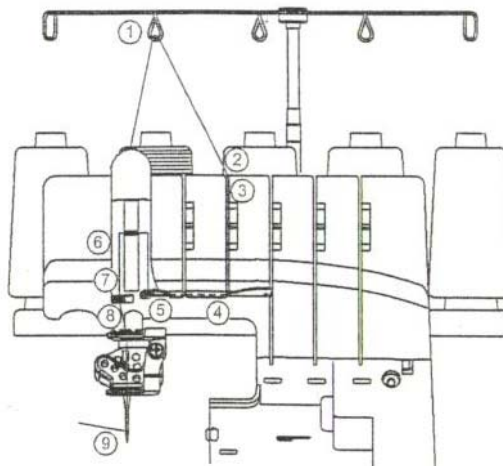

3. Thread the top cover thread guide by pulling the thread towards the left until it slips under the guide. Then pull the thread along the right side of the button as illustrated.

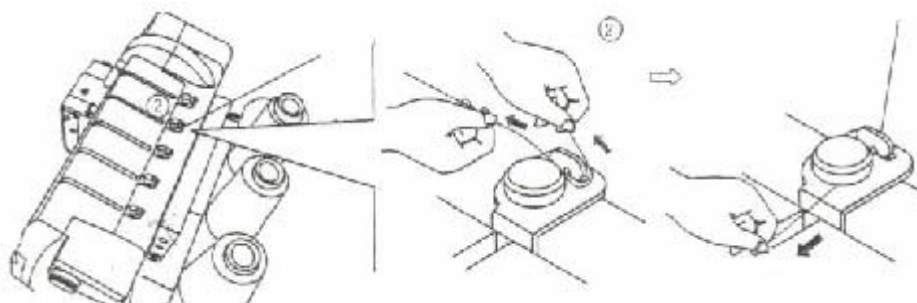

4. While holding the thread firmly, pull the thread between the tension disks.

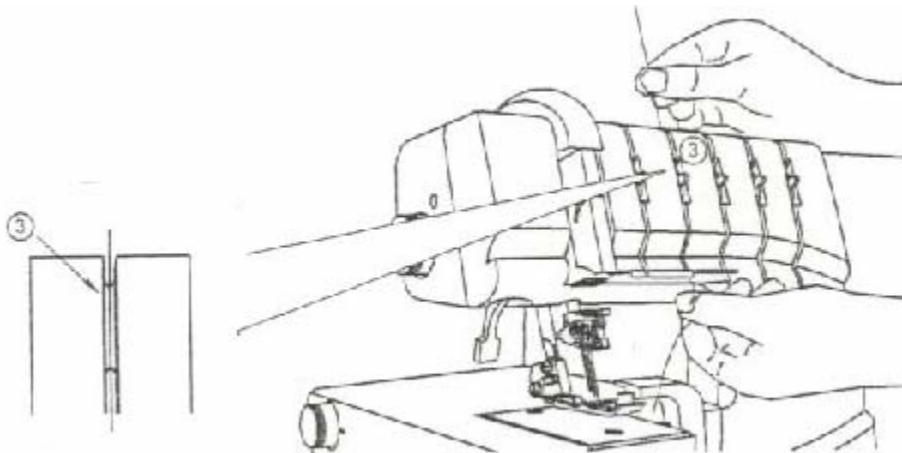

5. Continue to thread points 4-8. Slip the thread into the middle slot of the thread guide ⑤. Go over the take up lever ⑥. Continue by slipping the thread into the middle slot of the thread guides ⑦ and ⑧.
6. Before threading the eye of the needle, make sure the thread is in front of the thread guide located on the bottom of the needle clamp for the Cover Stitch or Chainstitch.

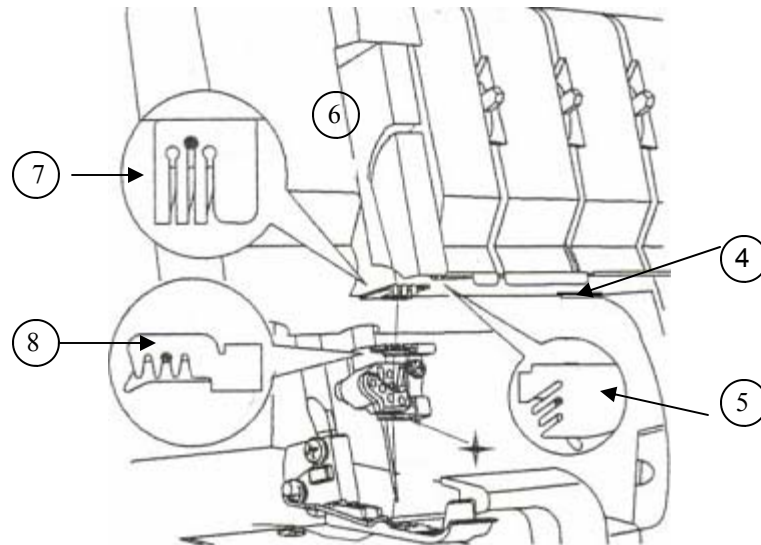

7. Thread the eye of the middle needle ⑨.

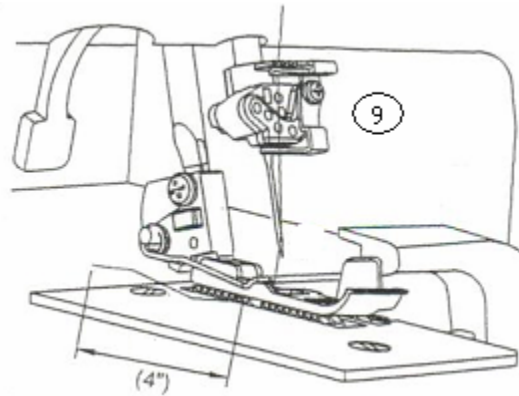

8. Draw about 4 inches of the thread through the needle eye towards the back of the machine.
9. Place the thread to the back, under the Presser Foot. Lower foot and sew.

◆ Thread Left Cover Stitch needle with regular thread.

1. Raise the Presser Foot to release the tension disks. Thread the left needle as illustrated 1-9.

2. Pass thread from back to the front through the thread guide ①.

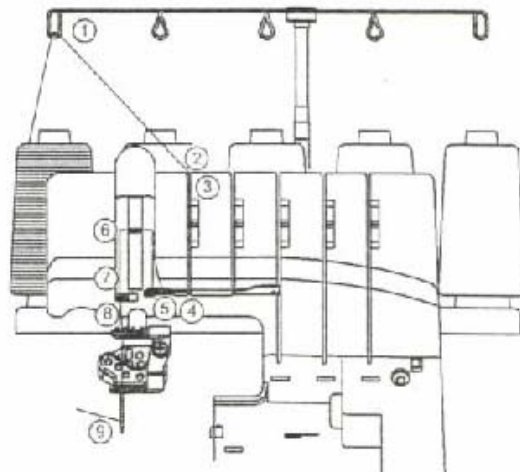
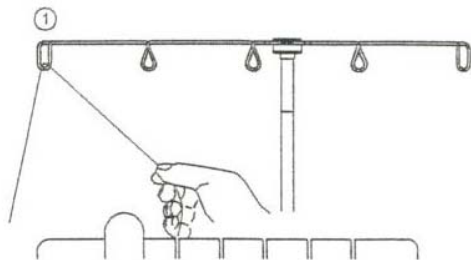

3. Thread the top cover thread guide by pulling the thread towards the left until it slips under the guide. Then pull the thread along the right side of the button as illustrated.

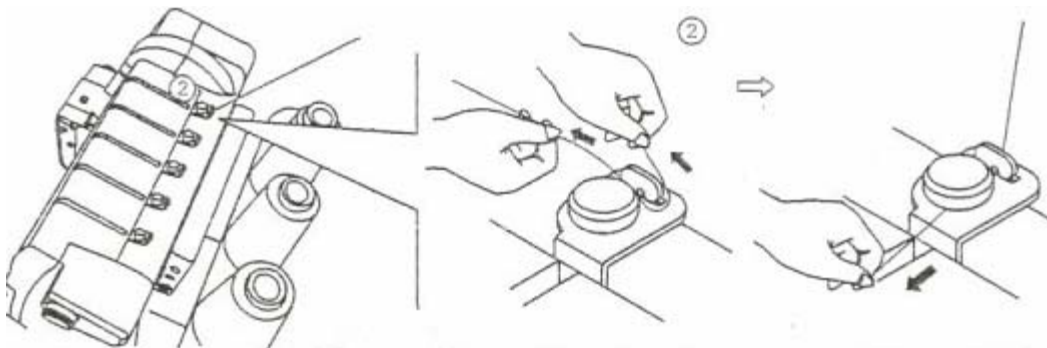

4. While holding the thread firmly, pull the thread between the tension disks.

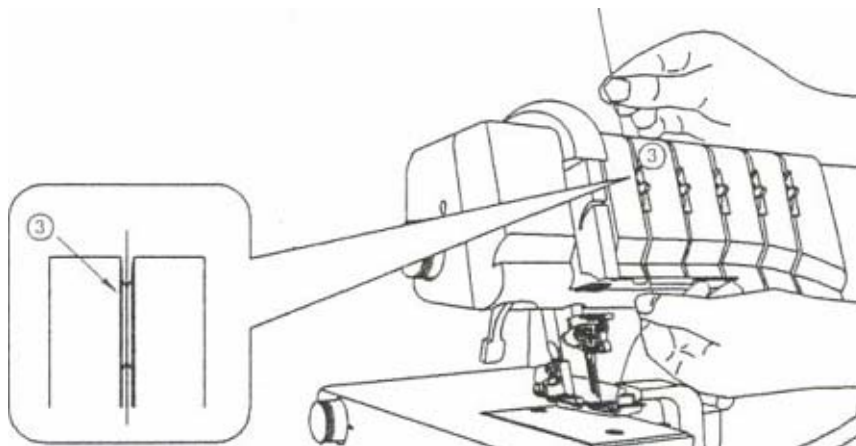



5. Continue to thread points 4-8. Slip the thread into the forward slot of the thread guide ⑤. Go over the take up lever ⑥. Continue by slipping the thread into the left slot of the thread guides ⑦ and ⑧.
6. Before threading the eye of the needle, make sure the thread is in front of the thread guide located on the bottom of the needle clamp.

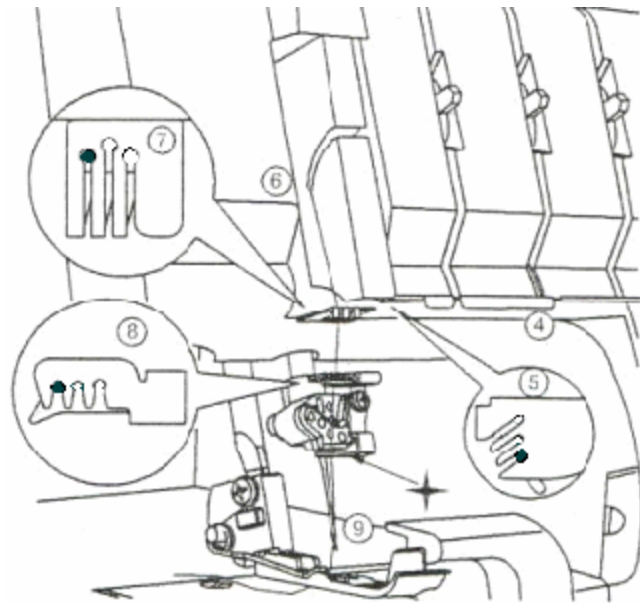

7. Thread the eye of the Left Cover Stitch Needle ⑨.



8. Draw about 4 inches of the thread through the needle eye towards the back of the machine.
9. Place the thread to the back, under the Presser Foot. Lower foot and sew.

## Try It:

- ◆ Press a 1" hem into a knit fabric.
- ◆ Lift the Presser Foot to the highest position.
- ◆ Position the fabric right side up and under the needles.
- ◆ Align the fabric so that the fabric fold is 1" to the right of the needles. Use markings on cover for positioning and guiding fabric.
- ◆ Lower the Presser Foot.
- ◆ Turn the handwheel to assist in the stitch forming on the fabric. When sewing the Cover Hem Stitch it is necessary to have fabric under the needles while sewing.
- ◆ Sew, using the seam guides for a straight hem and to ensure the fabric's raw edge is finished.
- ◆ As the machine sews it will finish the fabric's raw edge and sew two rows of topstitching.

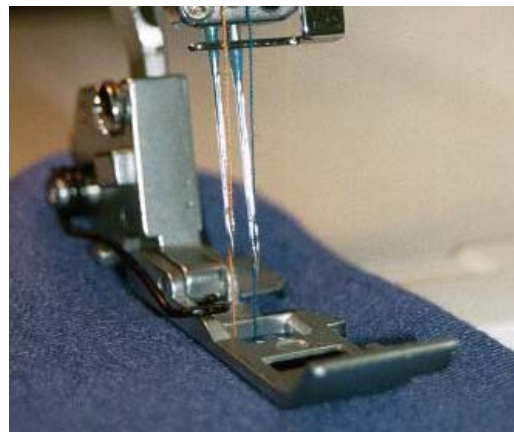

## Cover Stitch Wide

This professional Cover Hem stitch is a necessary requirement for today's sewing. The stitch is often seen in ready-to-wear garments. Two needles create parallel rows of top stitching and one looper sew an edge finish on the underneath side. Depending on which needle position is selected the width can be 5.6mm wide or 2.8 mm wide.



Left Cover Needle Thread    Right Cover Needle Thread

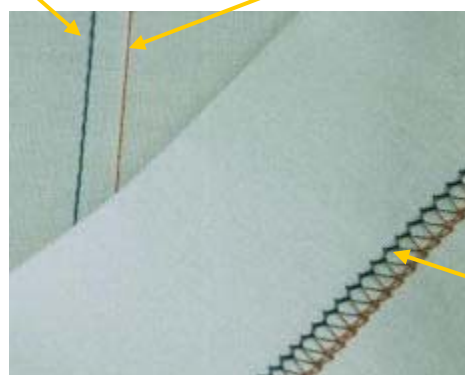

Cover Stitch Looper Thread

## Set up:

### Needle:

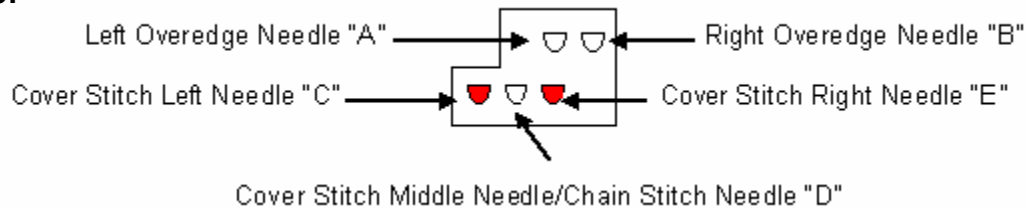

### Set at:

<b>ATD:</b> Auto Tension Dial	"H"
Left Cover Stitch Needle "C" (Orange)	Threaded
Middle Cover Stitch Needle "D"	Not Threaded
Right Cover Stitch Needle "E" (Green)	Threaded
Overedge Left Needle "A" (Orange)	Threaded
Overedge Right Needle "B" (Blue)	Threaded
Upper Looper	Looper Disengaged and Not Threaded
Spreader	Not Used
Lower Looper	Not Threaded
Chain Stitch Looper (Brown)	Threaded
Upper Looper Clutch	"C"
Upper Knife	Non-working Position
Seam Guide Plate	Installed
Seam Width Dial	"N"
Stitch Length Dial	"N"
Presser Foot Pressure	"N"
Differential Feed Dial	"N"
Stitch Finger	"R"

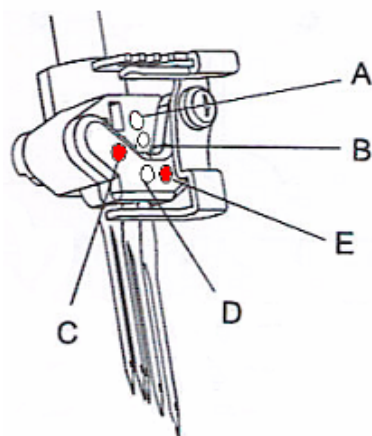

## Cover Stitch Wide

- ◆ Turn Auto Tension Dial to “H”.

- ◆ Turn Stitch Length Dial to “N”.



- ◆ Disengage Upper Knife. The knife will not trim the fabric when it is disengaged.
  1. Open Looper Cover.
  2. Pull the movable knife holder (silver screw) to the right as far as it will go.
  3. Turn the holder counter clockwise until the knife clicks into a lock position.

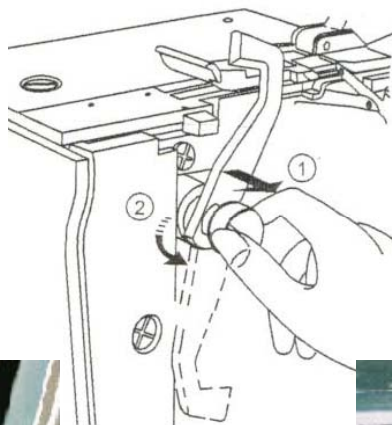

Upper Knife Engaged



Upper Knife Disengaged

# SINGER®

- ◆ Turn Presser Foot Pressure Dial to “N”.



- ◆ Turn Differential Feed Dial to “N”.



- ◆ Turn Seam Width Dial to “N”.



- ◆ Set Stitch Finger to “R”.

# SINGER®

- ◆ Install the Seam Guide Plate. The Seam Guide Plate provides a flat surface for the fabric and seam guides. It can only be used when the knife and the lower looper are disengaged. The Seam Guide Plate is used when sewing the Chainstitch, Cover Stitch and the Triple Cover Stitch.

1. Open Looper Cover.
2. Remove Knife Cover by pulling it toward you.
3. Slide the Seam Guide Plate into place.

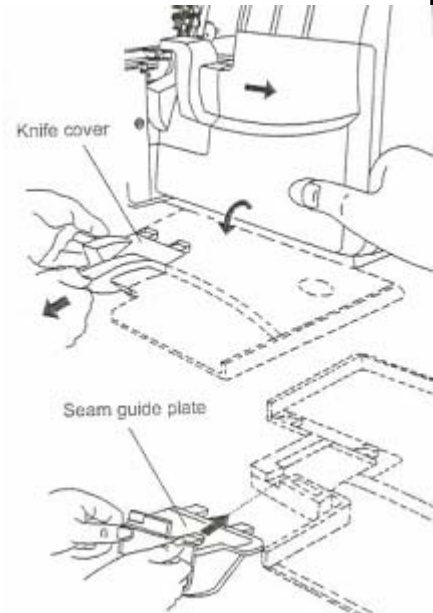

- ◆ Disengage Upper Looper. By disengaging the Upper Looper the looper no longer moves when sewing, it is nonoperative. If the looper was still engaged it would hit the Seam Guide Plate.

1. Turn handwheel until the Upper Looper is in the lowest position.
2. Push the clutch button to the left and up to disengage.

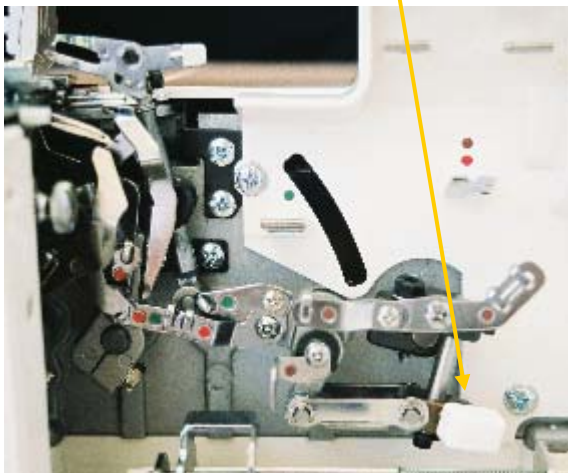

Upper Looper Engaged

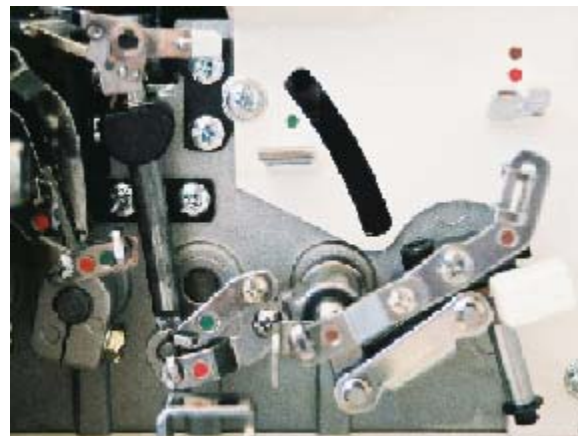
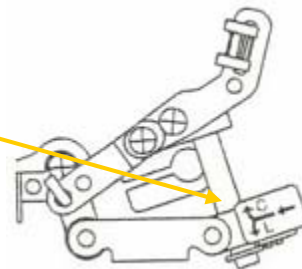

Upper Looper Disengaged

◆ Thread Chainstitch Looper with a regular overlock thread.

1. Raise the Presser Foot to release the tension disks. Pass the thread from the back to the front through the thread guide ①.

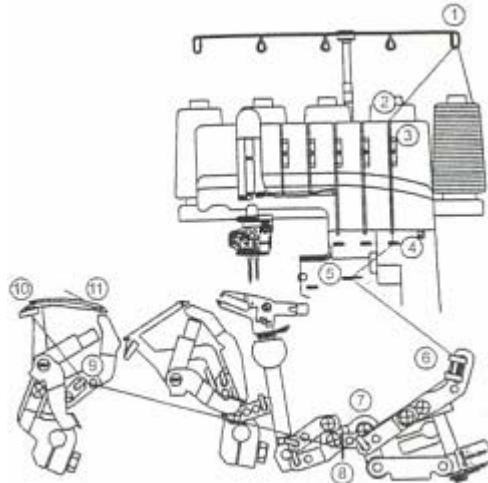
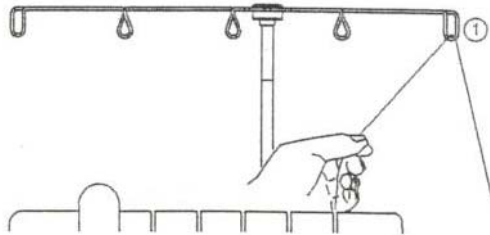

2. Thread the top cover thread guide by pulling the thread towards the left until it slips under the guide. Then pull thread along the right side of the button as illustrated.

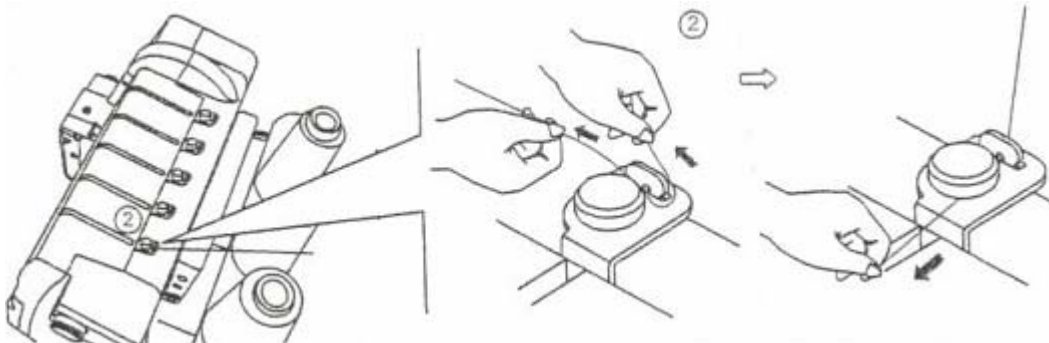

3. While holding the thread firmly, pull the thread between the tension disks.

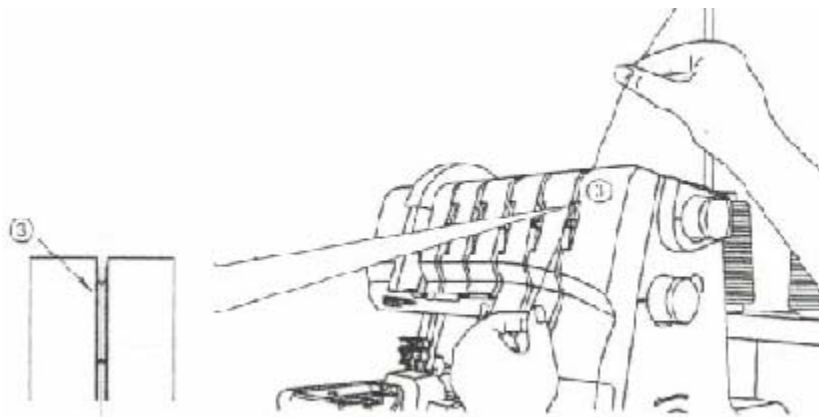



4. Turn the hand wheel toward you until the Chainstitch Looper extends out 10mm (approximately ½ inch) from the needle plate edge.

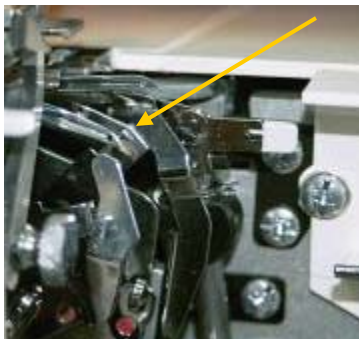

5. Thread the looper area of the machine following the brown color-coded thread guides 4-11. Use the tweezers provided in the accessory case to aid in threading the looper.

6. Place the thread through threading guide ④ and ⑤.

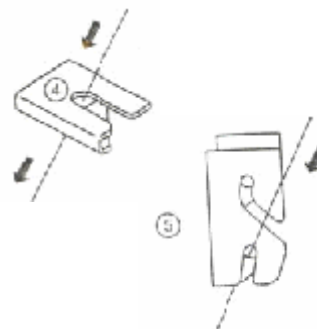

7. Continue threading guides ⑥, ⑦, ⑧ and ⑨.

8. Thread the looper eye (A) from front to back. Pull about 4 inches of thread through the looper. Position the thread into the V cutout (B) on the threader. Firmly hold the thread tail with your left hand and pull threader lever (C) up into place (D). Gently pull 5-6" of thread to the back of the machine.

⑩

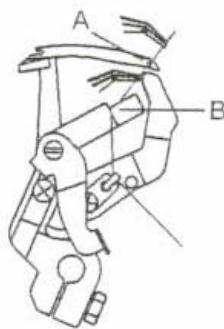

⑪

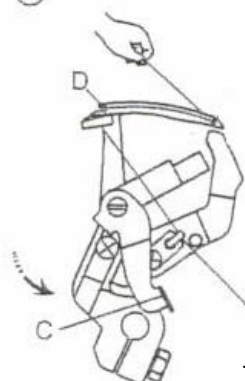

"V" cutout

Threader Lever

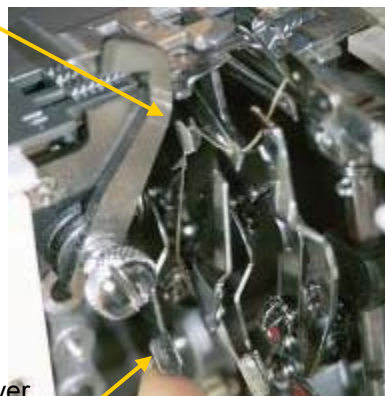

◆ Thread Right Cover Stitch needle with regular thread.

1. Raise the Presser Foot to release the tension disks. Thread the left needle as illustrated 1-9.

2. Pass thread from back to the front through the thread guide ①.

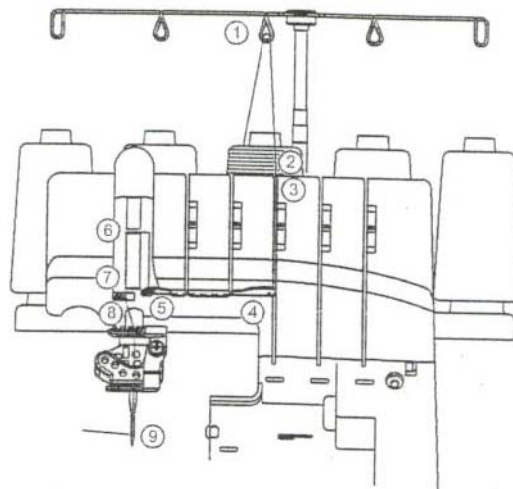
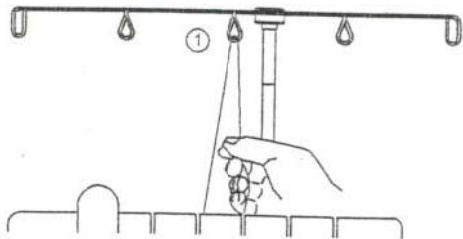

3. Thread the top cover thread guide by pulling the thread towards the left until it slips under the guide. Then pull the thread along the right side of the button as illustrated.

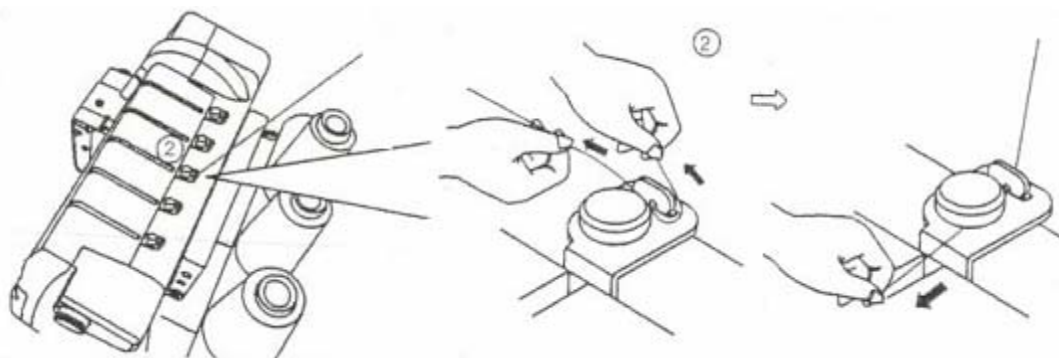

4. While holding the thread firmly, pull the thread between the tension disks.

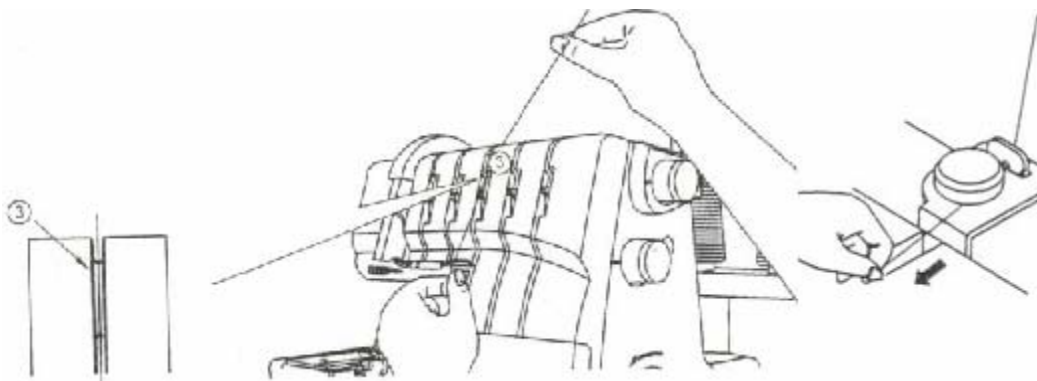

5. Continue to thread points 4-8. Slip the thread into the middle slot of the thread guide ⑤. Go over the take up lever ⑥. Continue by slipping the thread into the middle slot of the thread guides ⑦ and ⑧.
6. Before threading the eye of the needle, make sure the thread is in front of the thread guide located on the bottom of the needle clamp.

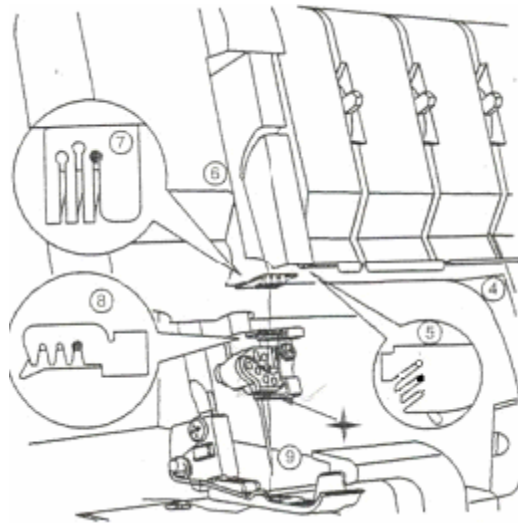

7. Thread the eye of the Right Cover Stitch Needle ⑨.



8. Draw about 4 inches of the thread through the needle eye towards the back of the machine.
9. Place the thread to the back, under the Presser Foot. Lower foot and sew.

◆ Thread Left Cover Stitch needle with regular thread.

1. Raise the Presser Foot to release the tension disks. Thread the left needle as illustrated 1-9.

2. Pass thread from back to the front through the thread guide ①.

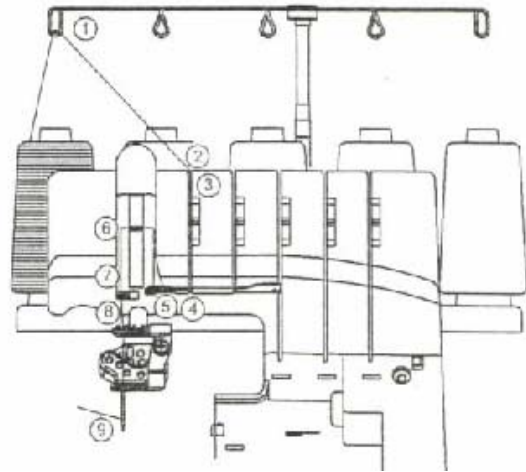
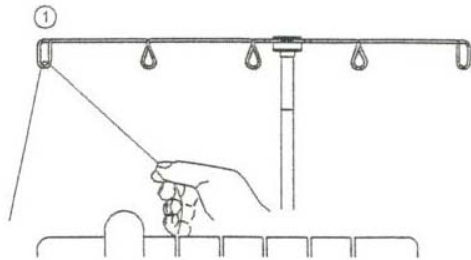

3. Thread the top cover thread guide by pulling the thread towards the left until it slips under the guide. Then pull the thread along the right side of the button as illustrated.

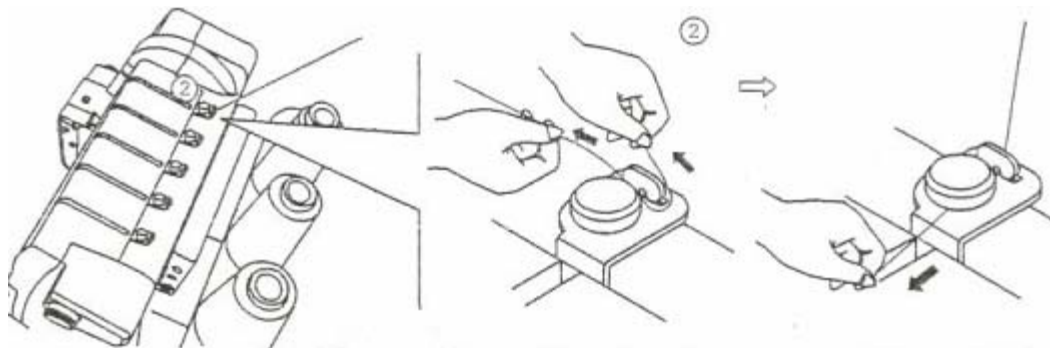

4. While holding the thread firmly, pull the thread between the tension disks.

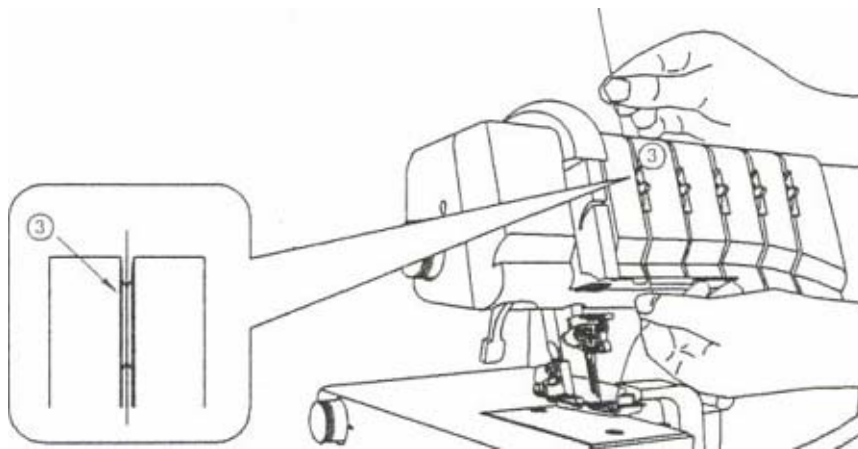

5. Continue to thread points 4-8. Slip the thread into the front slot of the thread guide ⑤. Go over the take up lever ⑥. Continue by slipping the thread into the left slots of the thread guides ⑦ and ⑧.
6. Before threading the eye of the needle, make sure the thread is in front of the thread guide located on the bottom of the needle clamp.

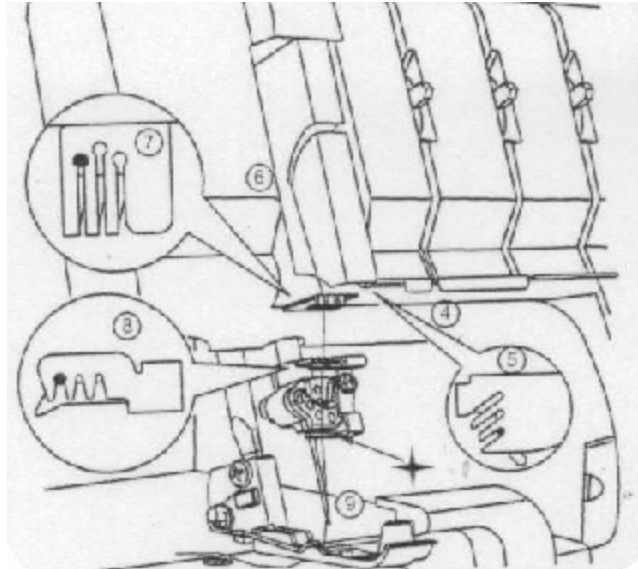

7. Thread the eye of the Left Cover Stitch Needle ⑨.

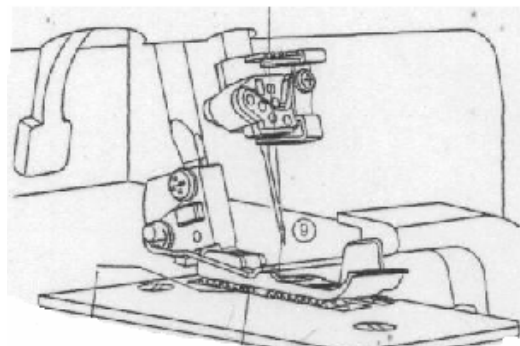

8. Draw about 4 inches of the thread through the needle eye towards the back of the machine.
9. Place the thread to the back, under the Presser Foot. Lower foot and sew.

# SINGER®

## Try It:

- ◆ Press a 1" hem into a knit fabric.
- ◆ Lift the Presser Foot to the highest position.
- ◆ Position the fabric right side up and under the needles.
- ◆ Align the fabric so that that the fabric fold is 1" to the right of the needles.
- ◆ Lower the Presser Foot.
- ◆ Turn the handwheel to assist in the stitch forming on the fabric. When sewing the Cover Hem Stitch it is necessary to have fabric under the needles while sewing. Sew off onto a scrap fabric.
- ◆ Sew using the seam guides for a straight hem and to ensure the fabric's raw edge is finished.
- ◆ As the machine sews it will finish the fabric's raw edge and sew three rows of topstitching.



## Triple Cover Stitch

This innovative stitch provides a very wide 5.6 mm professional and creative triple topstitch to sewing projects. Three needles create parallel rows of topstitching and one looper sews an edge finish on the underneath side. This is ideal for heavier fabrics traditionally used in home decorating. It also adds a unique accent for garment construction. In addition to sewing on woven fabrics, the Triple Cover Hem makes a beautiful topstitch and a strong hem on stretch fabrics. This stitch emulates hem finishing as seen on ready-to-wear garments.

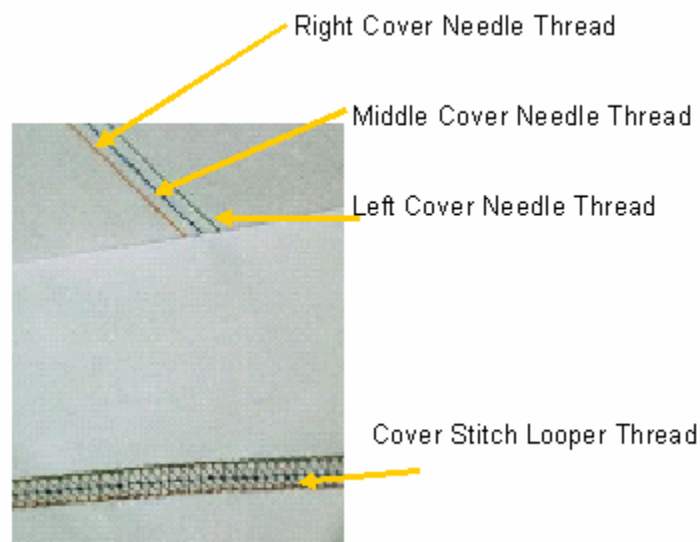

## Set up:

### Needles:

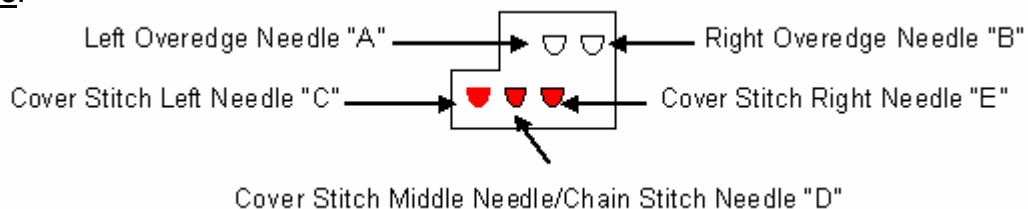

### Set at:

<b>ATD:</b> Auto Tension Dial	"J"
Left Cover Stitch Needle "C" (Orange)	Threaded
Middle Cover Stitch Nee- dle "D" (Blue)	Threaded
Right Cover Stitch Needle "E" (Green)	Threaded
Upper Looper	Looper Disengaged and Not Threaded
Spreader	Not Used
Lower Looper	Not Threaded
Chain Stitch Looper (Brown)	Threaded
Upper Looper Clutch	"C"
Upper Knife	Non-working Position
Seam Guide Plate	Installed
Seam Width Dial	"N"
Stitch Length Dial	"N"
Presser Foot Pressure	"N"
Differential Feed Dial	"N"
Stitch Finger	"R"

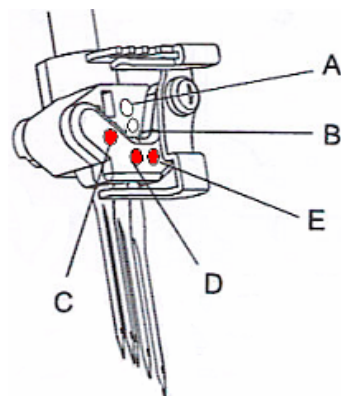



- ◆ Turn Auto Tension Dial to “J”.

- ◆ Turn Stitch Length Dial to “N”.

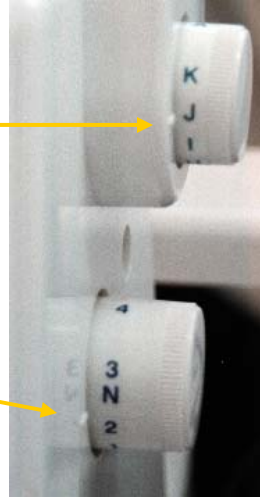

- ◆ Disengage Upper Knife. The knife will not trim the fabric when it is disengaged.
  1. Open Looper Cover.
  2. Pull the movable knife holder (silver screw) to the right as far as it will go.
  3. Turn the holder counter clockwise until the knife clicks into a lock position.

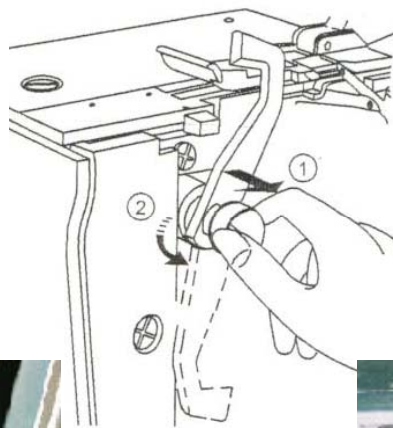

Upper Knife Engaged



Upper Knife Disengaged

# SINGER®

- ◆ Turn Presser Foot Pressure Dial to “N”.



- ◆ Turn Differential Feed Dial to “N”.



- ◆ Turn Seam Width Dial to “N”.

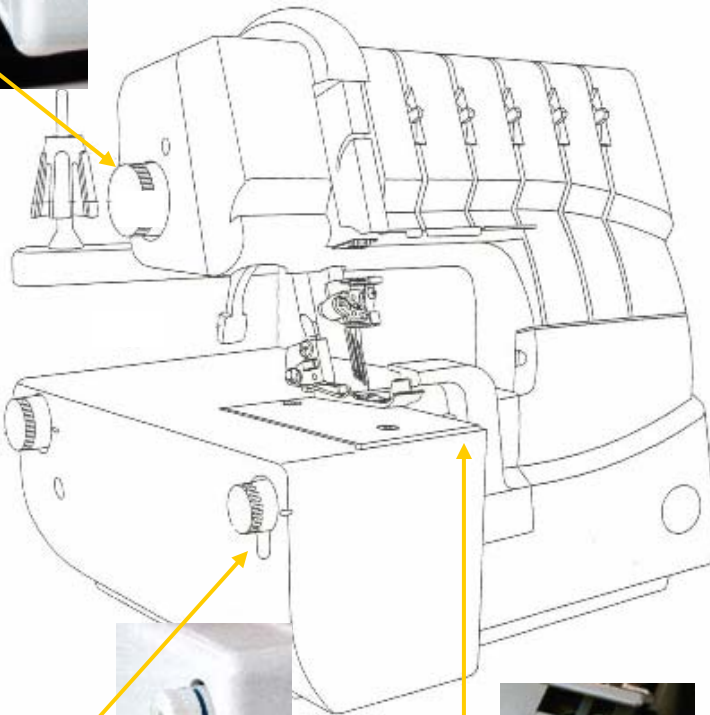

- ◆ Set Stitch Finger to “R”.

# SINGER®

- ◆ Install the Seam Guide Plate. The Seam Guide Plate provides a flat surface for the fabric and seam guides. It can only be used when the knife and the lower looper are disengaged. The Seam Guide Plate is used when sewing the Chainstitch, Cover Stitch and the Triple Cover Stitch.

1. Open Looper Cover.
2. Remove Knife Cover by pulling it toward you.
3. Slide the Seam Guide Plate into place.

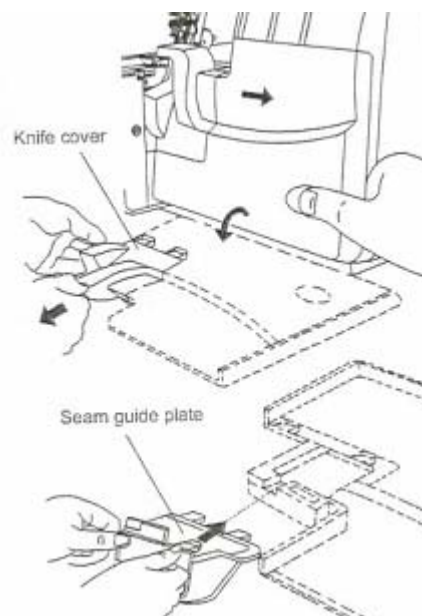

- ◆ Disengage Upper Looper. By disengaging the Upper Looper the looper no longer moves when sewing. It is nonoperative. If the looper was still engaged it would hit the Seam Guide Plate.

1. Turn handwheel until the Upper Looper is in the lowest position.
2. Push the clutch button to the left and up to disengage.

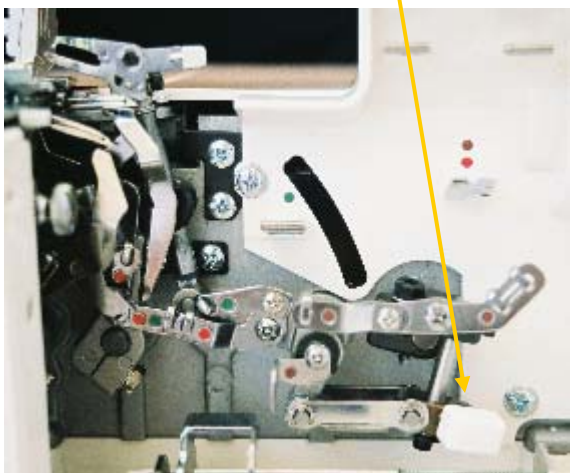

Upper Looper Engaged

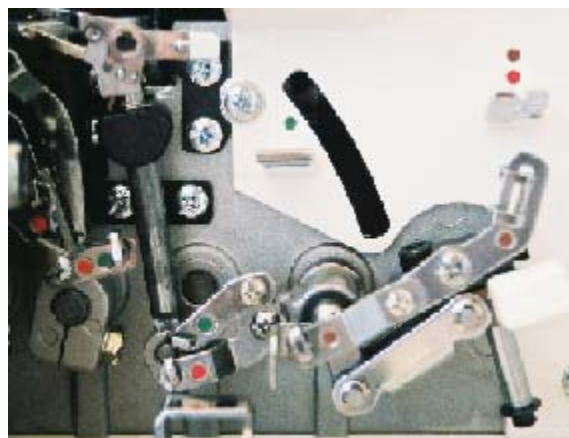
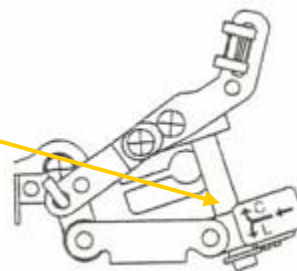

Upper Looper Disengaged

◆ Thread Chainstitch Looper with a regular overlock thread.

1. Raise the Presser Foot to release the tension disks. Pass the thread from the back to the front through the thread guide ①.

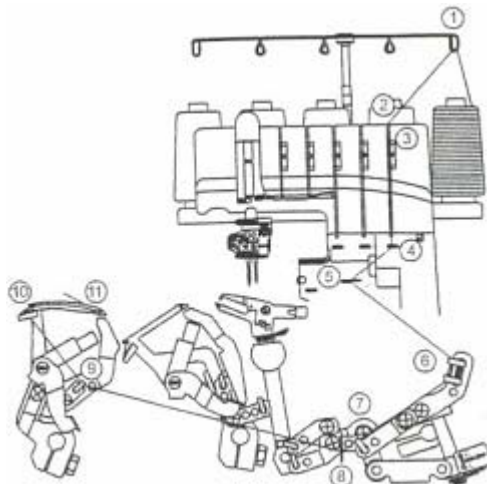
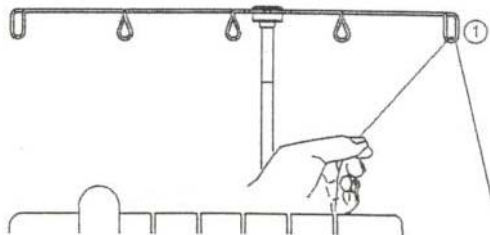

2. Thread the top cover thread guide by pulling the thread towards the left until it slips under the guide. Then pull thread along the right side of the button as illustrated.

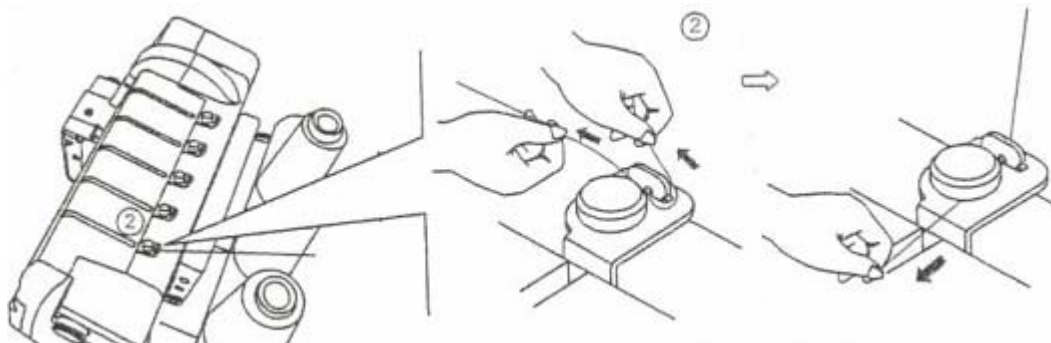

3. While holding the thread firmly, pull the thread between the tension disks.

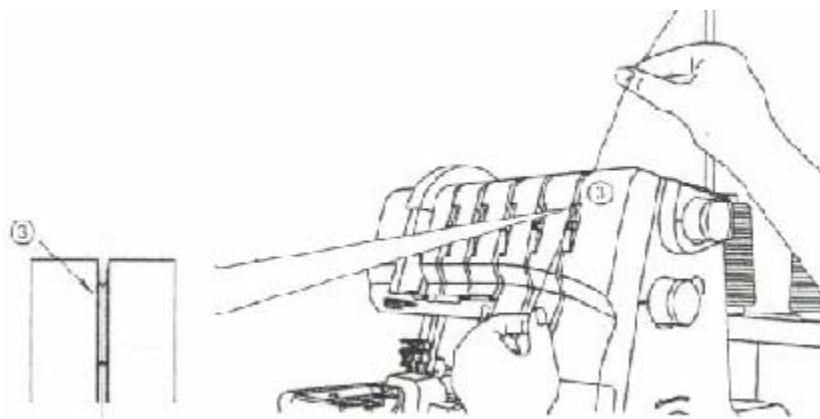

4. Turn the hand wheel toward you until the Chainstitch Looper extends out 10mm (approximately ½ inch) from the needle plate edge.



5. Thread the looper area of the machine following the brown color-coded thread guides 4-11. Use the tweezers provided in the accessory case to aid in threading the looper.

6. Place the thread through threading guides ④ and ⑤.

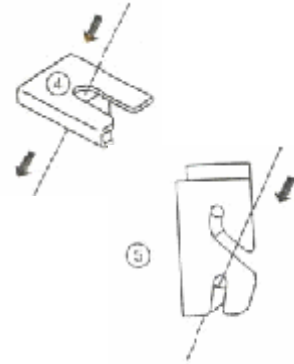

7. Continue threading guides ⑥, ⑦, ⑧ and ⑨.

8. Thread the looper eye (A) from front to back. Pull about 4 inches of thread through the looper. Position the thread into the V cutout (B) on the threader. Firmly hold the thread tail with your left hand and pull threader lever (C) up into place (D). Gently pull 5-6" of thread to the back of the machine.

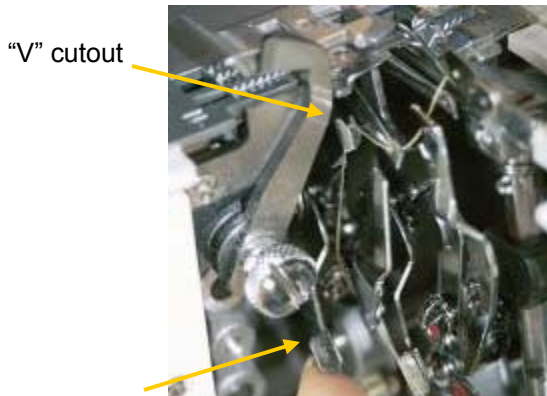
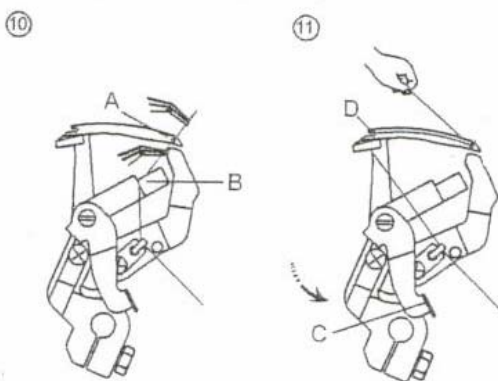

Threader Lever

◆ Thread Right Cover Stitch needle with regular thread.

1. Raise the Presser Foot to release the tension disks. Thread the left needle as illustrated 1-9.

2. Pass thread from back to the front through the thread guide ①.

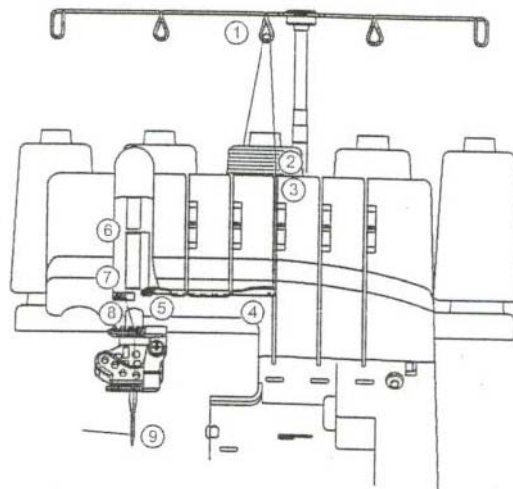
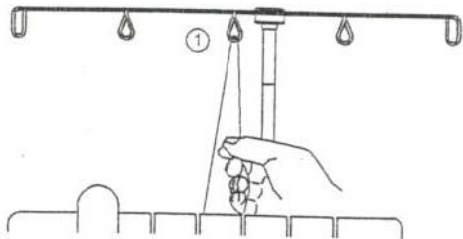

3. Thread the top cover thread guide by pulling the thread towards the left until it slips under the guide. Then pull the thread along the right side of the button as illustrated.

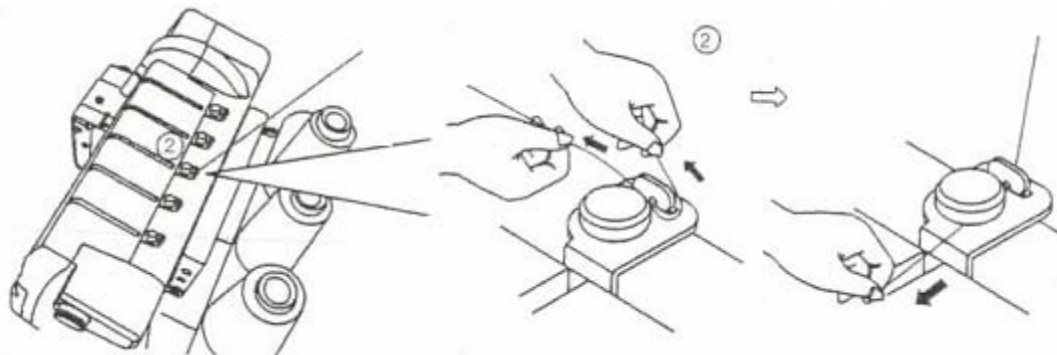

4. While holding the thread firmly, pull the thread between the tension disks.

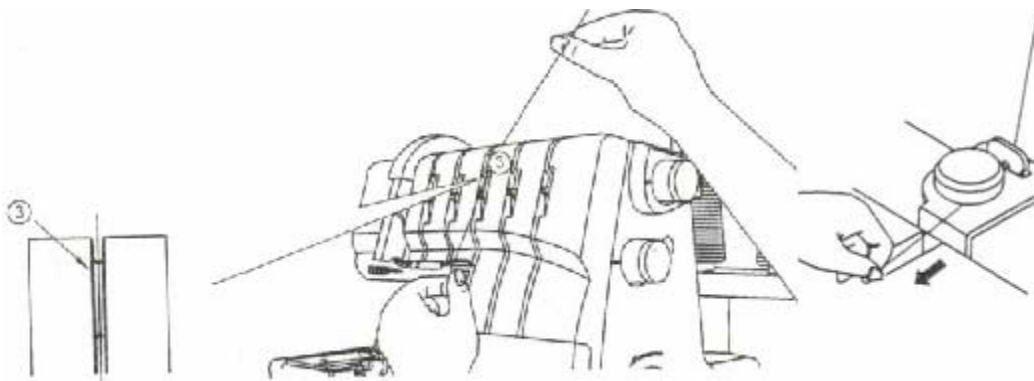

5. Continue to thread points 4-8. Slip the thread into the rear slot of the thread guide ⑤. Go over the take up lever ⑥. Continue by slipping the thread into the right slot of the thread guides ⑦ and ⑧.
6. Before threading the eye of the needle, make sure the thread is in front of the thread guide located on the bottom of the needle clamp.

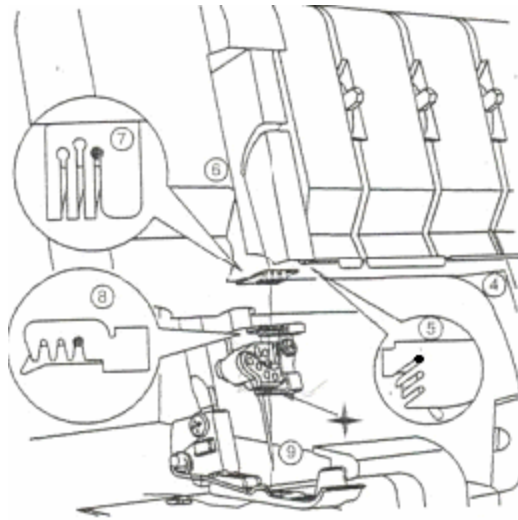

7. Thread the eye of the Right Cover Stitch Needle ⑨.



8. Draw about 4 inches of the thread through the needle eye towards the back of the machine.
9. Place the thread to the back, under the Presser Foot. Lower foot and sew.

◆ Thread Middle Cover needle with regular overlock thread.

1. Raise the Presser Foot to release the tension disks. Thread the Cover Stitch Middle/Chain Stitch needle as illustrated 1-9.
2. Pass thread from back to the front through the thread guide ①.

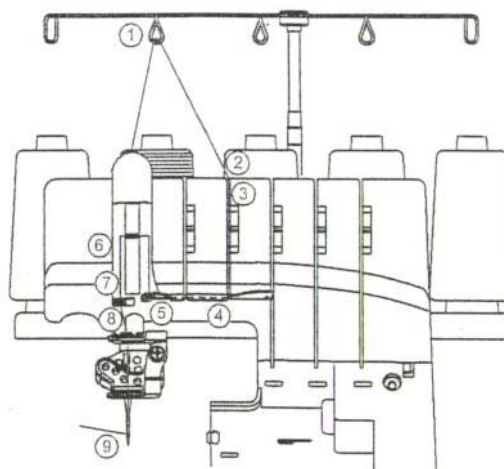

3. Thread the top cover thread guide by pulling the thread towards the left until it slips under the guide. Then pull the thread along the right side of the button as illustrated.

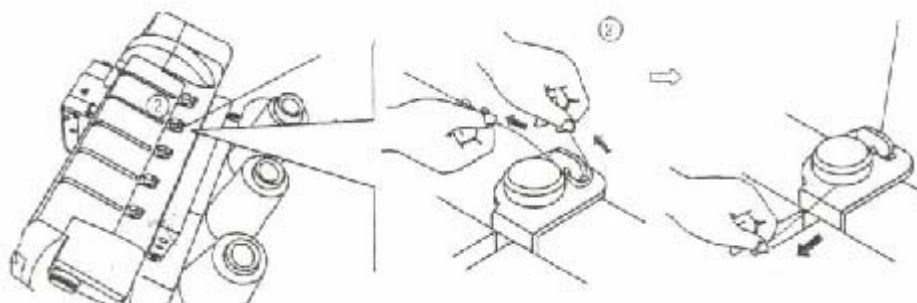

4. While holding the thread, firmly pull the thread between the tension disks.

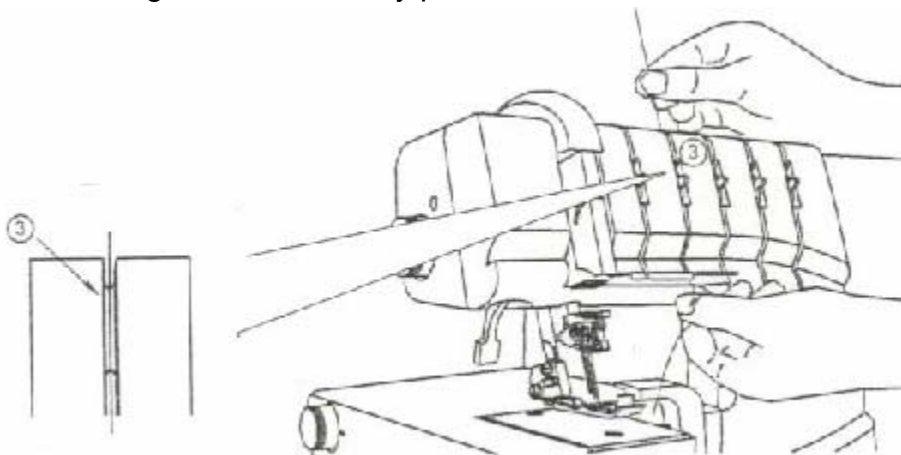



5. Continue to thread points 4-8. Slip the thread into the middle slot of the thread guide ⑤. Go over the take up lever ⑥. Continue by slipping the thread into the middle slot of the thread guides ⑦ and ⑧.
6. Before threading the eye of the needle, make sure the thread is in front of the thread guide located on the bottom of the needle clamp for the Cover Stitch or Chainstitch.

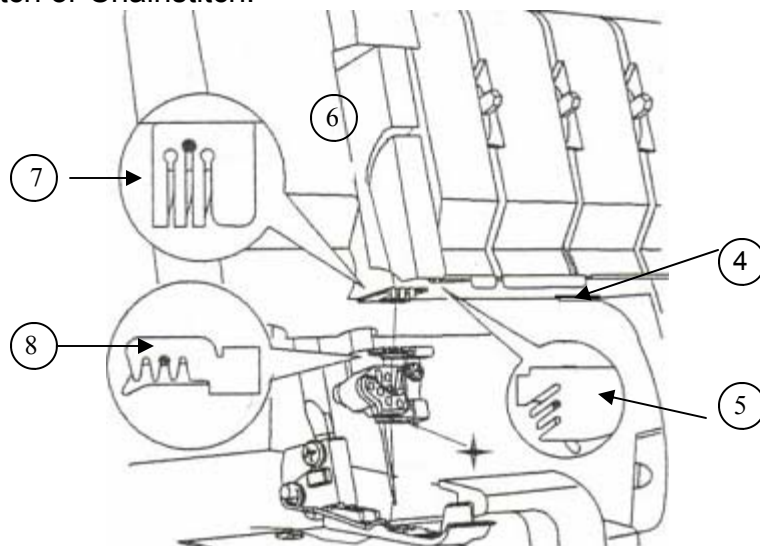

7. Thread the eye of the middle needle ⑨.

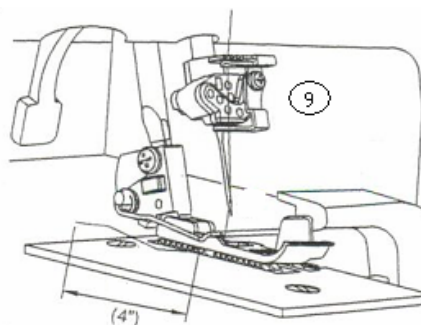

8. Draw about 4 inches of the thread through the needle eye towards the back of the machine.
9. Place the thread to the back, under the Presser Foot. Lower foot and sew.

◆ Thread Left Cover Stitch needle with regular thread.

1. Raise the Presser Foot to release the tension disks. Thread the left needle as illustrated 1-9.

2. Pass thread from back to the front through the thread guide ①.

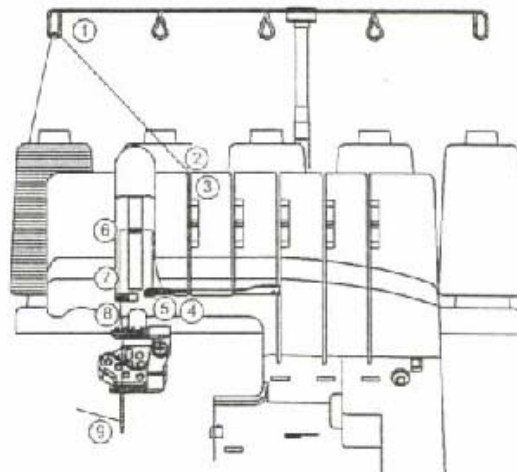
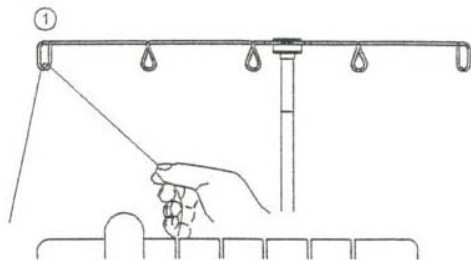

3. Thread the top cover thread guide by pulling the thread towards the left until it slips under the guide. Then pull the thread along the right side of the button as illustrated.

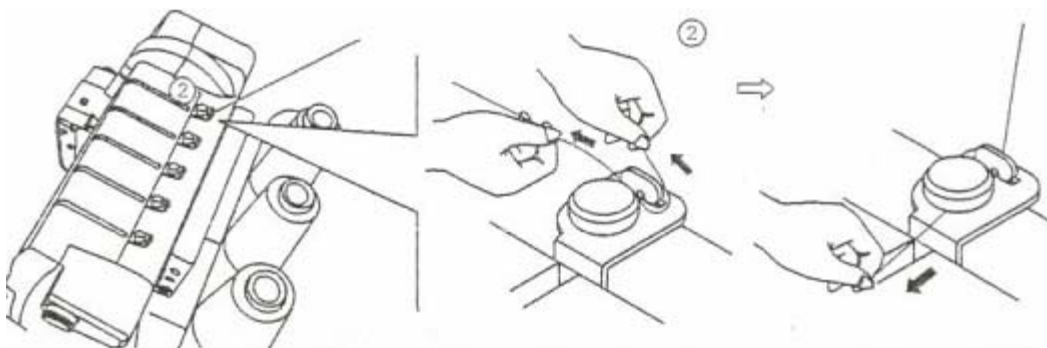

4. While holding the thread firmly, pull the thread between the tension disks.

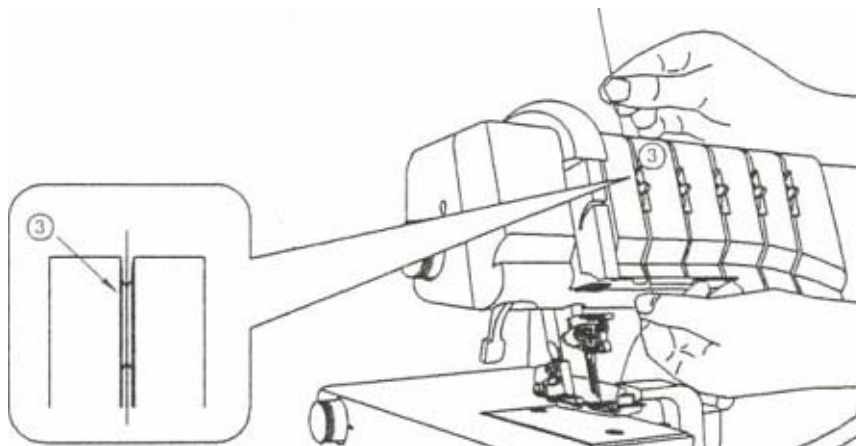

5. Continue to thread points 4-8. Slip the thread into the forward slot of the thread guide ⑤. Go over the take up lever ⑥. Continue by slipping the thread into the left slot of the thread guides ⑦ and ⑧.
6. Before threading the eye of the needle, make sure the thread is in front of the thread guide located on the bottom of the needle clamp.

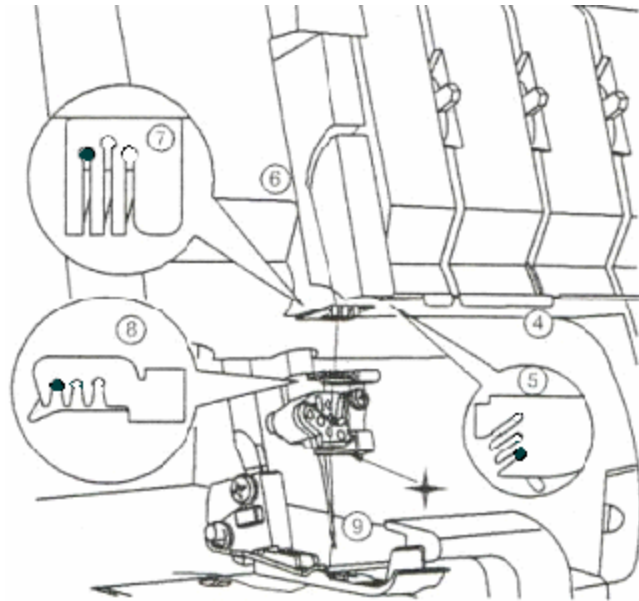

7. Thread the eye of the Left Cover Stitch Needle ⑨.



8. Draw about 4 inches of the thread through the needle eye towards the back of the machine.
9. Place the thread to the back, under the Presser Foot. Lower foot and sew.

# SINGER®

## Try It:

- ◆ Press a 3" hem into a woven home decorator fabric.
- ◆ Lift the Presser Foot to the highest position.
- ◆ Position the fabric right side up and under the needles.
- ◆ Align the fabric so that the fabric fold is 1" to the right of the needles.
- ◆ Lower the Presser Foot.
- ◆ Turn the handwheel to assist in the stitch forming on the fabric. When sewing the Triple Hem Stitch it is necessary to have fabric under the needles while sewing.
- ◆ Sew using the seam guides for a straight hem and to ensure the fabric's raw edge is finished.
- ◆ As the machine sews it will finish the fabric's raw edge and sew three rows of topstitching.

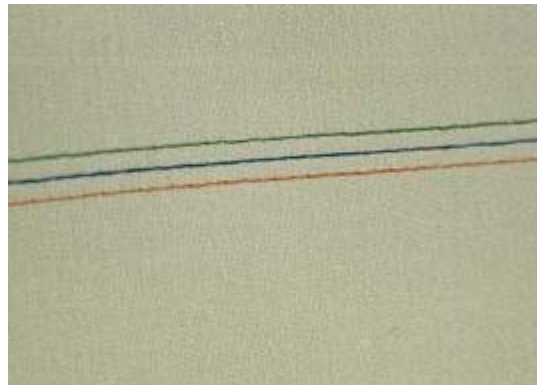

## Three-Thread Rolled Hem

The Rolled Hem Stitch is used to finish edges of scarves, ruffles, table linens, and some garments. It is suitable for lightweight to medium weight fabrics, such as sheers, silkies and broadcloth. Beautiful pintucks can be achieved with the rolled hem. They can enhance a yoke, heirloom sewing, wearable art and even home decorating projects. Note: Rolled hemming can only be performed with the Right Overedge needle all other needles must be removed.

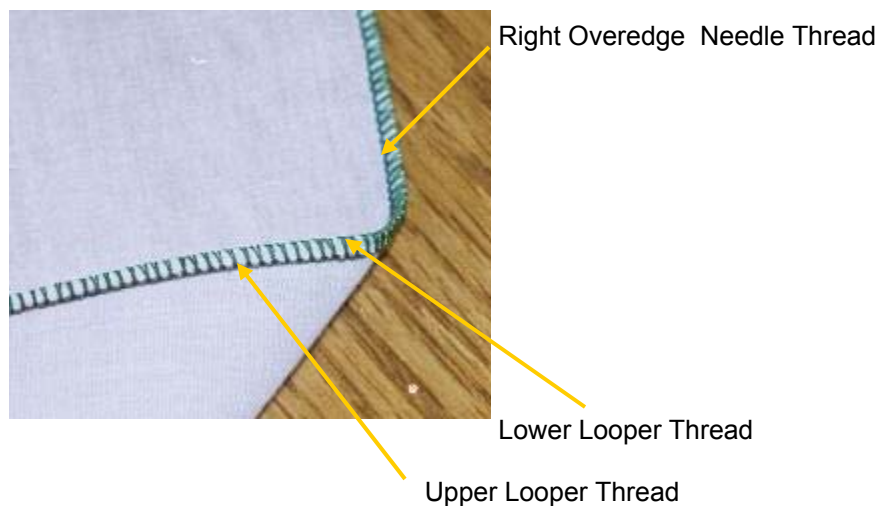
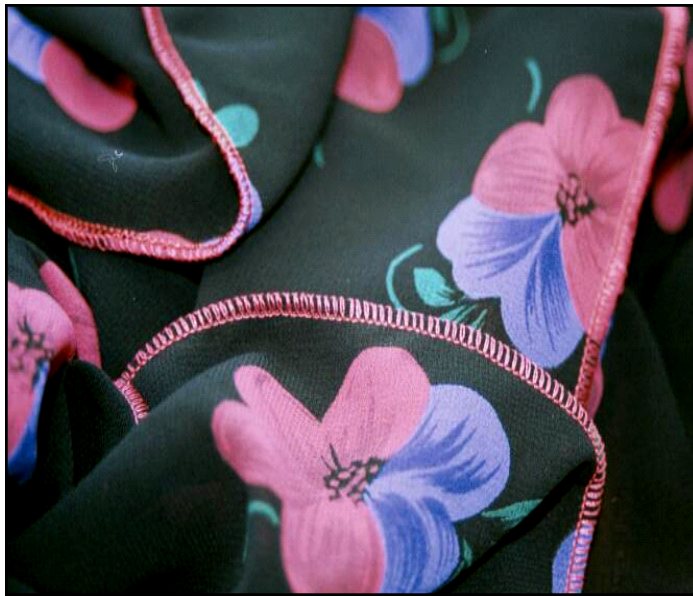

## Set up:

### Needles:

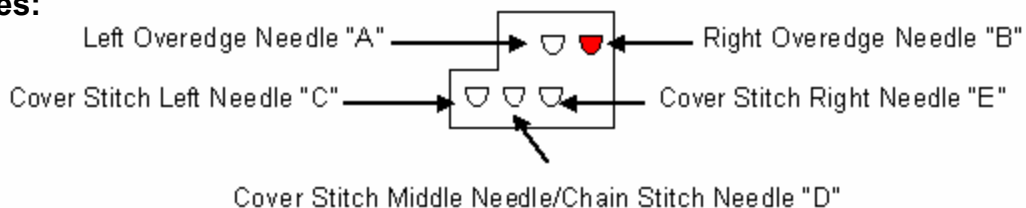

### Set at:

<b>ATD:</b> Auto Tension Dial	"C"
Left Cover Stitch Needle "C"	Not Threaded
Middle Cover Stitch Needle "D"	Not Threaded
Right Cover Stitch Needle "E"	Not Threaded
Overedge Left Needle "A"	Not Threaded
Overedge Right Needle "B" (Blue)	Threaded
Upper Looper (Green)	Looper Engaged and Threaded
Spreader	Not Used
Lower Looper (Red)	Threaded
Chain Stitch Looper (Brown)	Not Threaded
Upper Looper Clutch	"L"
Upper Knife	Engaged
Seam Guide Plate	Not Installed Use Knife Cover
Seam Width Dial	"N"
Stitch Length Dial	"1"
Presser Foot Pressure	"N"
Differential Feed Dial	"N"
Stitch Finger	"R"

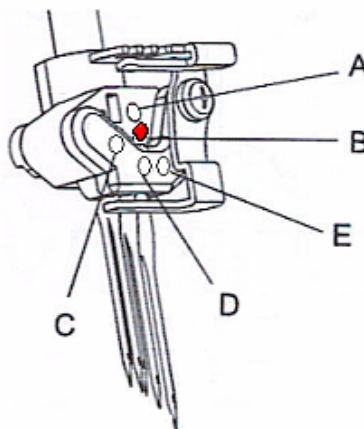

# SINGER®

- ◆ Turn Auto Tension Dial to “C”.

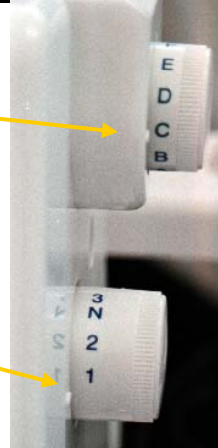

- ◆ Turn Stitch Length Dial to “1”.

- ◆ Engage Upper Knife. The knife will not trim the fabric when it is disengaged.
  1. Open Looper Cover.
  2. Pull the movable knife holder (silver screw) to the right as far as it will go.
  3. Turn the holder clockwise until the knife clicks into a lock position.

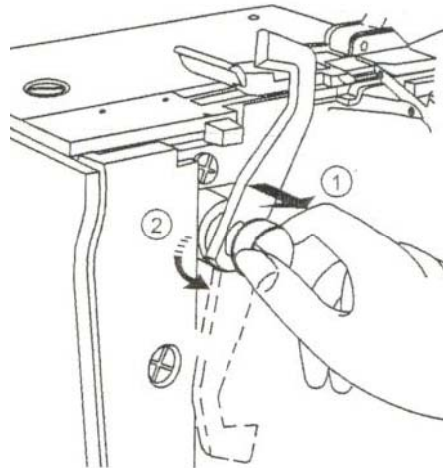

Upper Knife Disengaged



Upper Knife Engaged

- ◆ Turn Presser Foot Pressure Dial to “N”.



- ◆ Turn Differential Feed Dial to “N”.



- ◆ Turn Seam Width Dial to “N”.



- ◆ Set Stitch Finger to “R”.





# SINGER®

## ◆ Install the Knife Cover.

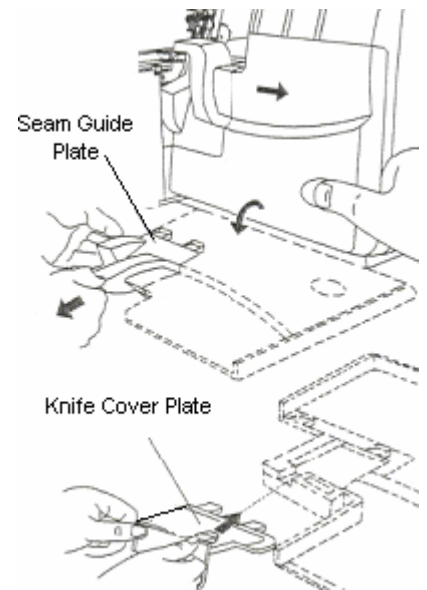

## ◆ Engage Upper Looper. Engaging the Upper Looper causes the looper to move when sewing. Even though the Upper Looper is not threaded it needs to be engaged.

1. Push the clutch button to the left and down to engage.
2. Turn handwheel.

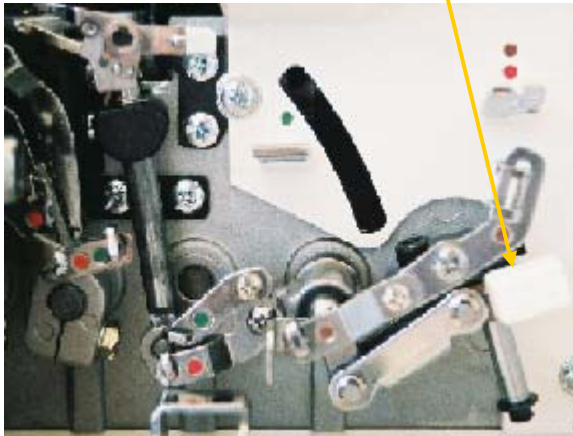

Upper Looper Disengaged

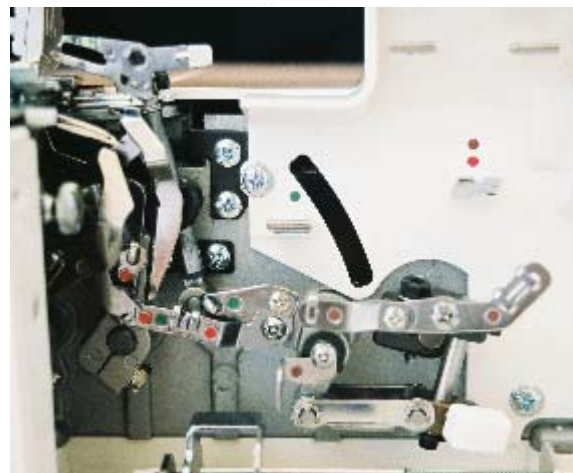
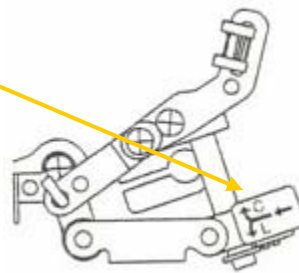

Upper Looper Engaged

- ◆ Disengage Spreader. The Upper Looter has a hole for the thread on the top of the looper. If the stitch requires that the looper be engaged, but not threaded then the Spreader is used. The Spreader simply plugs-in (or closes) the looper's hole. The Spreader is disengaged when the Upper Looter is engaged/operative and threaded. The Spreader is used with a stitch that requires only one looper thread. With the help of the Spreader the single looper thread wraps around the fabric's edge.
  1. Lower the white handle on the Spreader to open the eye of the Upper Looter.

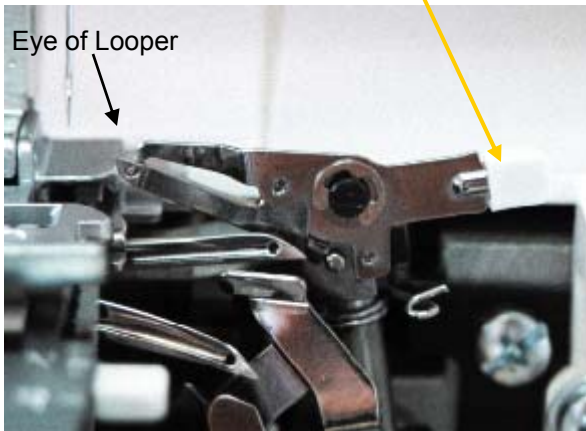

Spreader Engaged



Spreader Disengaged

- ◆ Thread Upper Looter with regular overlock thread.

1. Raise the Presser Foot to release the tension disks. Thread the Lower Looter as illustrated 1-9.

2. Pass thread from back to the front through the thread guide ①.

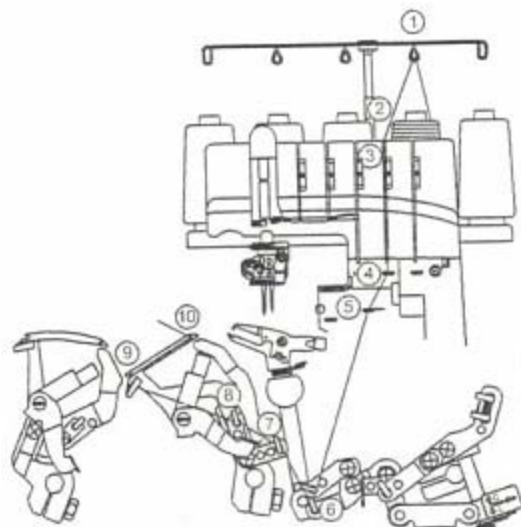
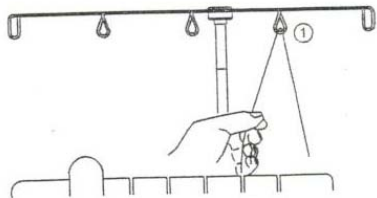

3. Thread the top cover thread guide by pulling the thread towards the left until it slips under the guide. Then pull the thread along the right side of the button as illustrated.

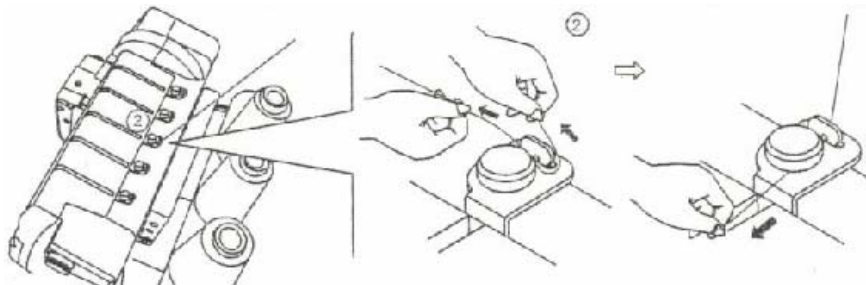

4. While holding the thread firmly, pull the thread between the tension disks.

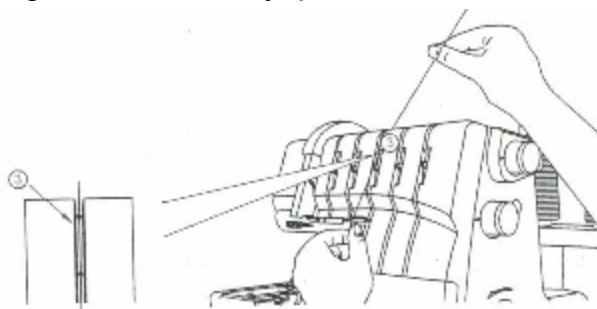

5. Turn the handwheel toward you until the lower looper extends 5-10mm (approximately 1/2 inch) from the needle plate edge.
6. Thread the looper area of the machine following the green color coded thread guides 4-9.

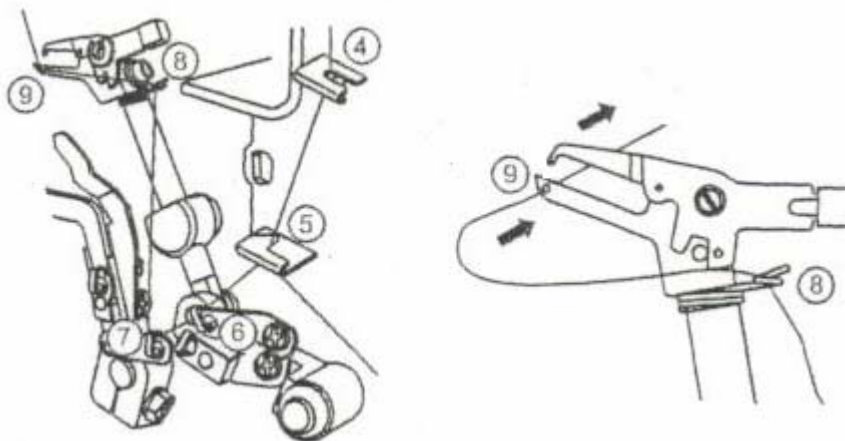

7. Thread the hole in the Upper Looter from front to back ⑨. Pull about 4 inches of thread through the looper and place to the back of the throat plate.

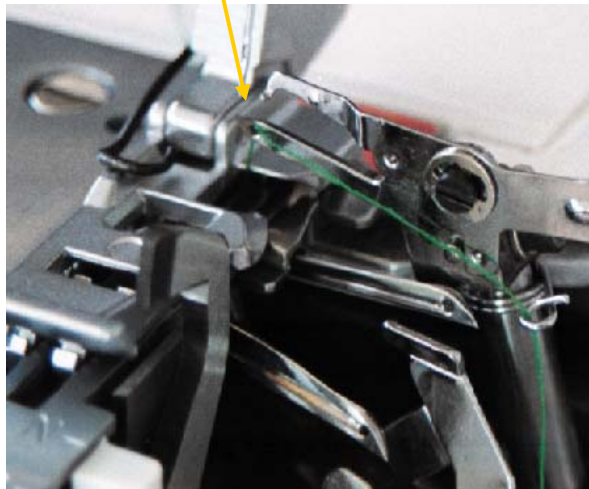

◆ Thread Lower Looter with regular overlock thread.

1. Raise the Presser Foot to release the tension disks. Thread the Lower Looter as illustrated 1-10.
2. Pass thread from back to the front through the thread guide ①.

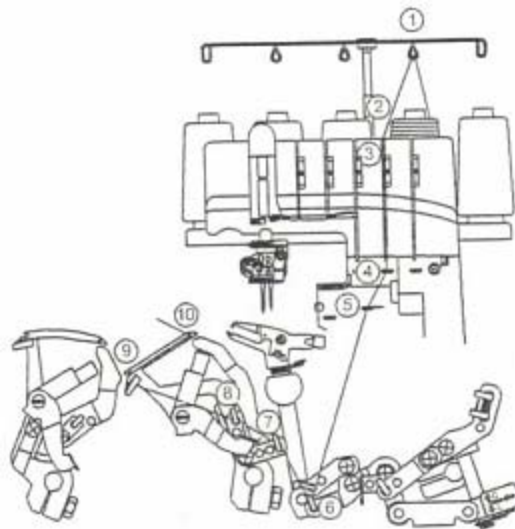
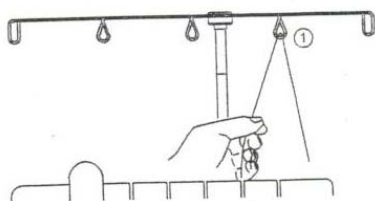

3. Thread the top cover thread guide by pulling the thread towards the left until it slips under the guide. Then pull the thread along the right side of the button as illustrated.

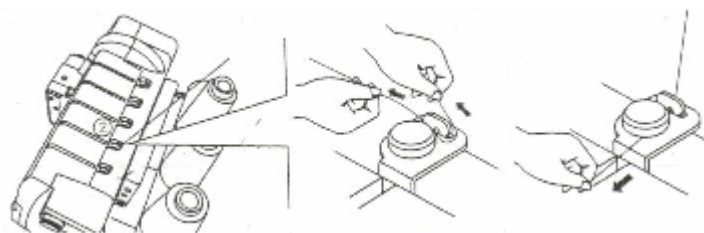

4. While holding the thread firmly, pull the thread between the tension disks.

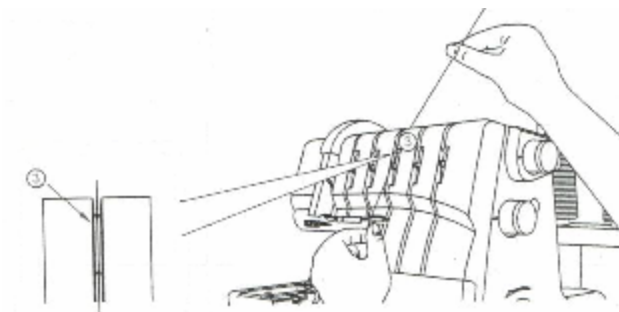

5. Turn the handwheel toward you until the lower looper extends 5-10mm (approximately ½ inch) from the needle plate edge.
6. Thread the looper area of the machine following the red color coded thread guides 4-10.

7. Place the thread slightly from left and to the right of threading guide ④.

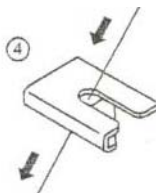

8. Place the thread slightly from the front and to the back of threading guide ⑤.

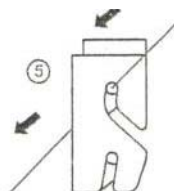

9. Place the thread through ⑥, ⑦ and ⑧.

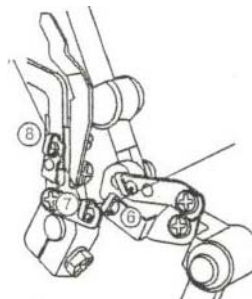

10. Thread the looper eye (A) from front to back. Pull about 4 inches of thread. Position thread into V cutout (B) on threader. Firmly hold thread tail with left hand and pull Threader lever (C) up into place (D).

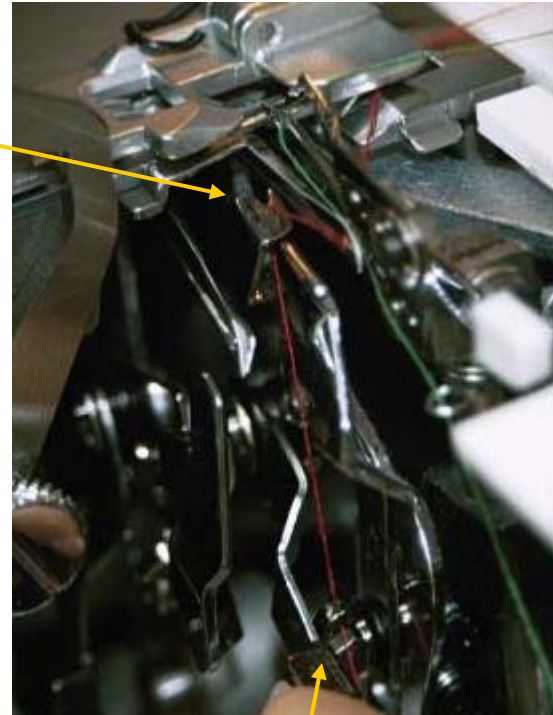
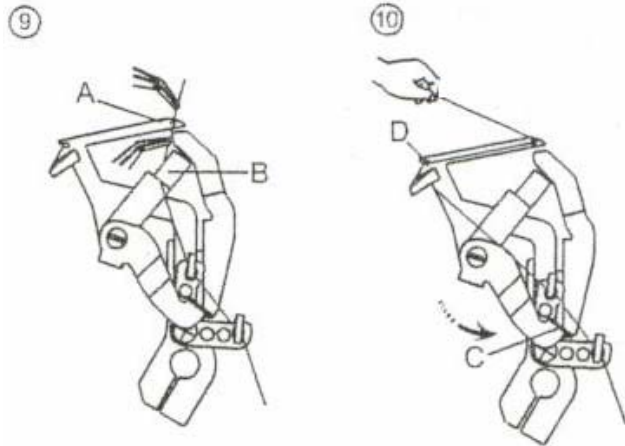

Threader Lever



NOTE: Make sure the Upper Looper thread is behind the Lower Looper thread.

◆ Thread Right Overedge needle with regular overlock thread.

1. Raise the Presser Foot to release the tension disks. Thread the right needle as illustrated 1-9.

2. Pass thread from back to the front through the thread guide ①.

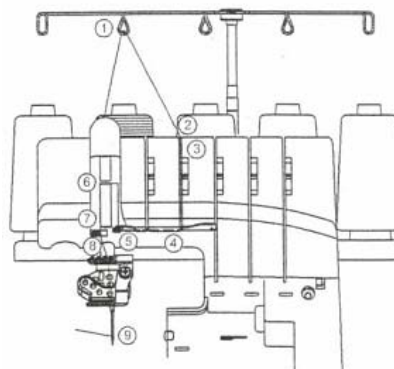
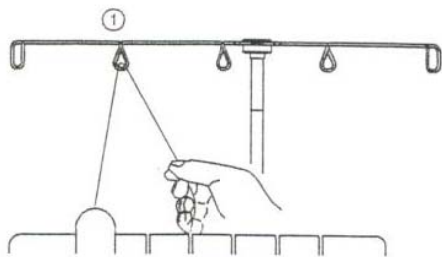

3. Thread the top cover thread guide by pulling the thread towards the left until it slips under the guide. Then pull the thread along the right side of the button as illustrated.

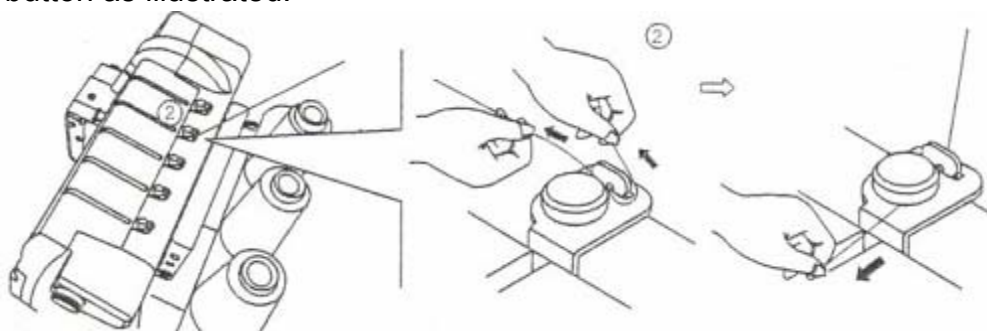

4. While holding the thread firmly, pull the thread between the tension disks.

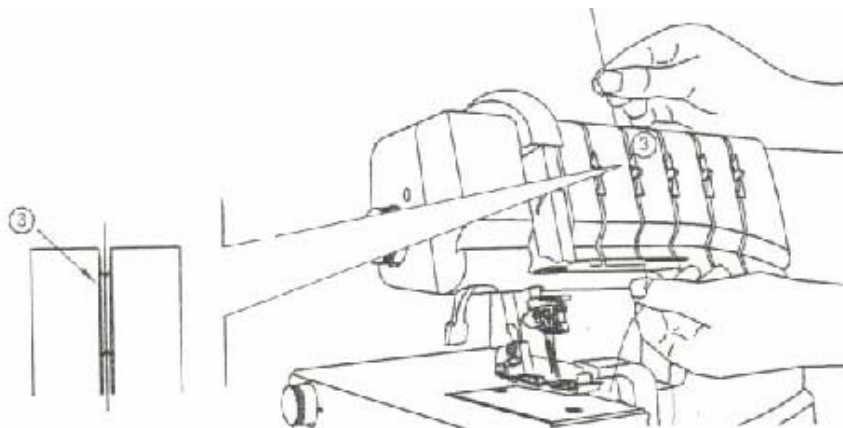

# SINGER®

5. Continue to thread points 4-8. Slip the thread into the rear slot of the thread guide ⑤. Go over the take up lever ⑥. Continue by slipping the thread into the right slots of the thread guides ⑦ and ⑧.
8. Before threading the eye of the needle, make sure the thread is behind the thread guide located on the bottom of the needle clamp.

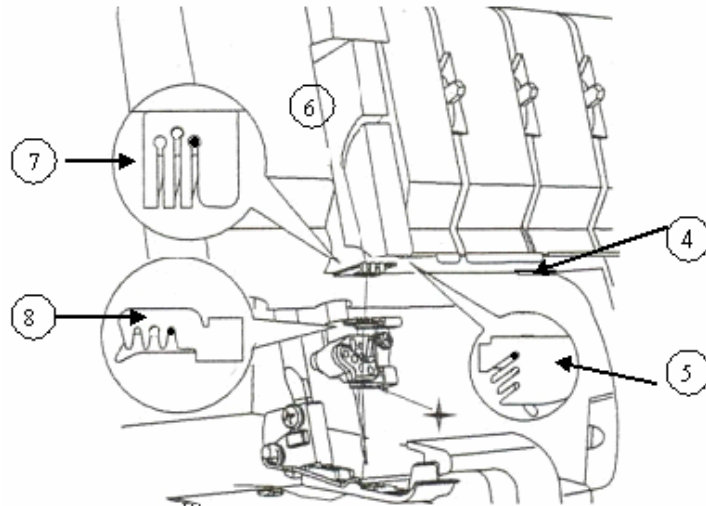

9. Draw about 4 inches of the thread through the needle eye towards the back of the machine.
10. Place the thread to the back, under the Presser Foot. Lower foot and sew.

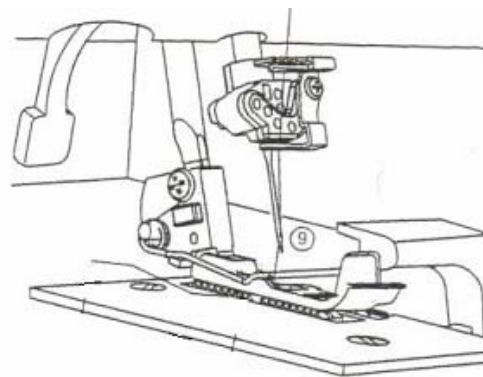



# SINGER®

## Try It:

- ◆ Align a piece of lightweight fabric so that the fabric's edge is being slightly trimmed by the knife.
- ◆ Sew.

