

MODEL 2111B PARTS DRAWING

3/5/2002

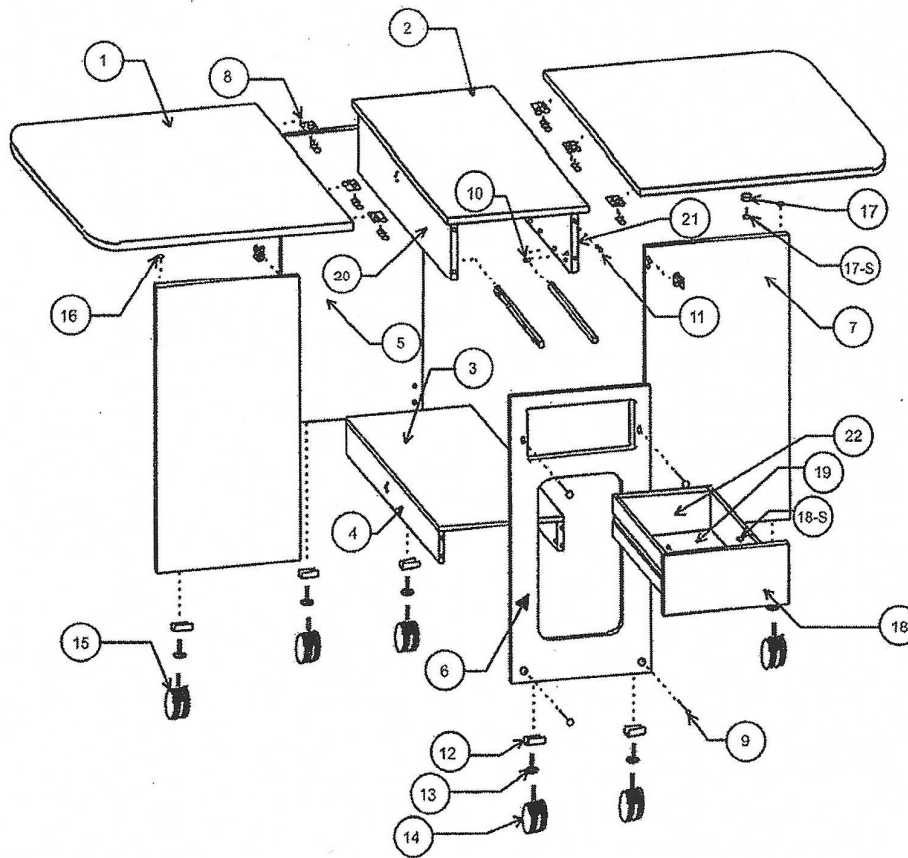

NOTE: WHEN ORDERING REPLACEMENT PARTS, PLEASE SPECIFY MODEL 2111B, PART NUMBER, AND COLOR.

PART NO.	DESCRIPTION	QUANT. REQ.	PART NO.	DESCRIPTION	QUANT. REQ.
2111B-1	DROP LEAF PANEL	2	2111B-13	CASTER PLASTIC SOCKET	6
2111B-2	CENTER TOP PANEL	1	2111B-14	NO LOCK CASTERS	4
2111B-3	BOTTOM SHELF PANEL	1	2111B-15	LOCK CASTER	2
2111B-4	BOTTOM STRETCHER RAILS	2	2111B-16	REST TACK	2
2111B-5	BACK END PANEL	1	2111B-17	PLASTIC STOP	2
2111B-6	FRONT END PANEL	1	2111B-17-S	STOP SCREWS 8 X 3/4" PH	4
2111B-7	SUPPORT PANELS	2	2111B-18	DRAWER FRONT	1
2111B-8	BUTT HINGE W/SCREWS	22	2111B-18-S	DR. FRONT SCREW 6 X 5/8" PH	4
2111B-9	CONNECTOR BOLTS	8	2111B-19	DRAWER BOTTOM	1
2111B-10	BARREL NUT	8	2111B-20	TOP LEFT STRETCHER RAIL	1
2111B-11	WOOD DOWEL	8	2111B-21	TOP RIGHT STRETCHER RAIL	1
2111B-12	CASTER BRACKET	6	2111B-22	PLASTIC DRAWER KIT INCLUDING SIDES-2, BACK-1, CONNECTORS-4 AND SLIDES-2.	1

HORN OF AMERICA INC.
P.O. BOX 608, SUTTON, WV 26601
1-800-882-8845

MEUBLES HORN INC./HORN FURNITURE INC.
42, RUE MONTCALM, ST-PIE (QUÉBEC) J0H 1W0
1-800-380-6661

MODEL 2111B HARDWARE

3/5/2002

1.

8-  1/4- 20x2 " CONNECTOR BOLT

2-  # 8X3/4 " PAN HEAD SCREW

4-  #6X9/16" PAN HEAD SCREW

30-  #5X9/16" FLAT HEAD SCREW

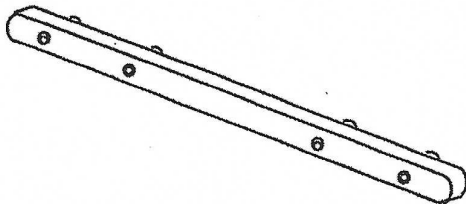

2- PLASTIC DRAWER SLIDE

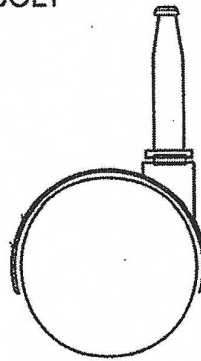

4- NON-LOCK
CASTER

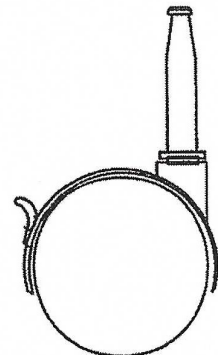

2- LOCK CASTER

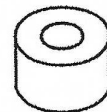

2- NYLON STOP

PANEL SUB-ASSEMBLY

1. INSTALL NYLON STOPS ON DROP LEAFS USING
(1) # 8X3/4 " SCREW FOR EACH NYLON STOP.
(NOTE : USE PRE-DRILLED HOLES FOR PROPER LOCATION.) REF. #1

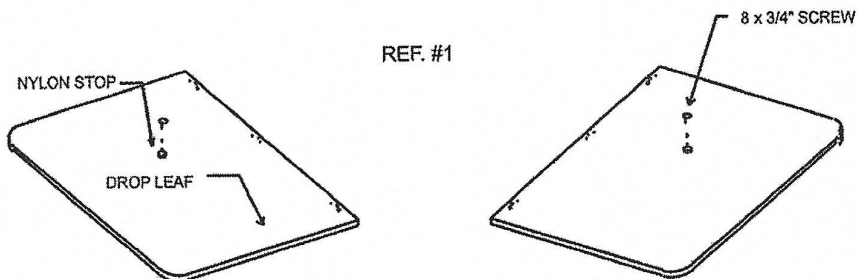

2. LAY TOP ASSEMBLY FLAT AND UNFOLD UPPER STRETCHER RAILS.
POSITION DRAWER SLIDES IN HOLES INSIDE UPPER STRETCHER RAILS
AND GENTLY TAP IN UNTIL SLIDES ARE FLAT ON PANEL. REF. #2

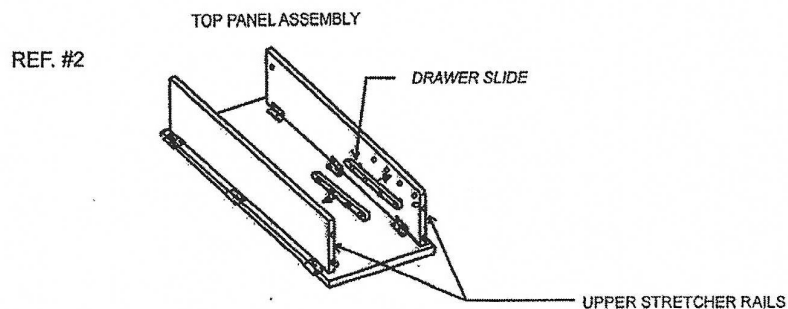

2111B ASSEMBLY INSTRUCTIONS

3/5/2002

2.

REF. #3

TOP PANEL ASSEMBLY

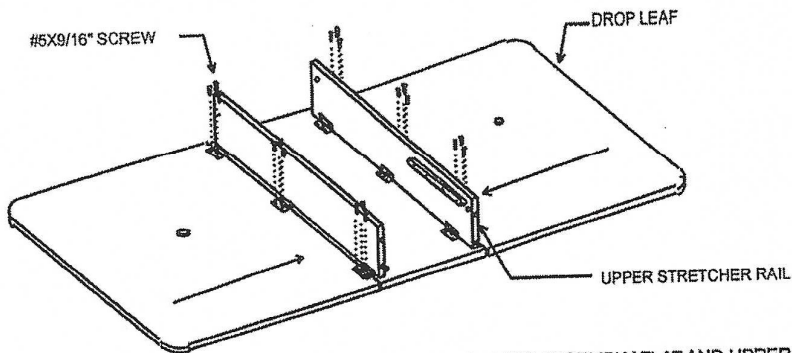

1. WITH TOP ASSEMBLY FLAT AND UPPER STRETCHER RAILS UNFOLDED, SLIDE DROP LEAF INTO POSITION. SECURE HINGES WITH (3) # 5X9/16" SCREWS PER HINGE. (NOTE : USE PRE-DRILLED PILOT HOLES FOR PROPER PANEL LOCATION.) REF. #3

REF. #4

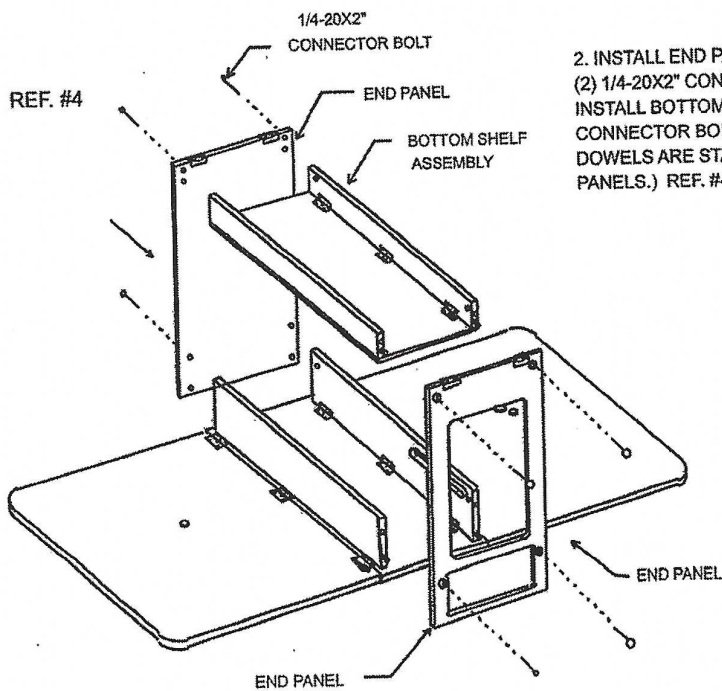

2. INSTALL END PANELS TO TOP ASSEMBLY USING (2) 1/4-20X2" CONNECTOR BOLTS PER PANEL. THEN INSTALL BOTTOM SHELF ASSEMBLY USING (2) 1/4-20X2" CONNECTOR BOLTS PER PANEL. (NOTE: MAKE SURE WOODEN DOWELS ARE STARTED IN END PANELS BEFORE SECURING PANELS.) REF. #4

2111B INSTRUCTIONS

3/5/2002

3.

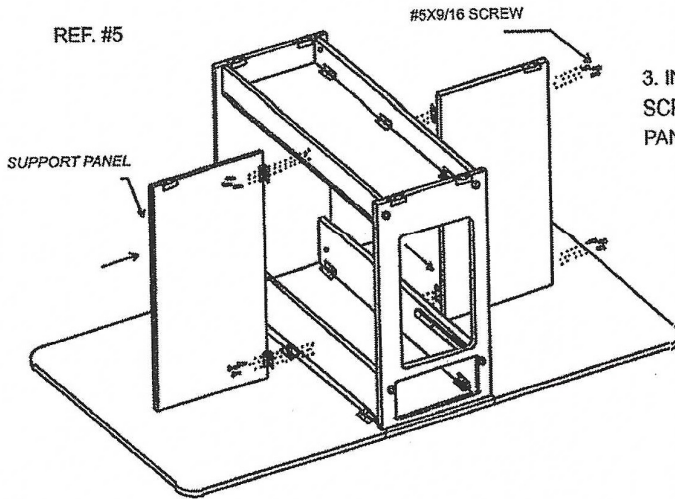

3. INSTALL SUPPORT PANELS USING (3) #5X9/16" SCREWS PER HINGE. (NOTE : PILOT HOLES FOR PROPER PANEL LOCATION.) REF. #5

4. INSTALL CASTERS: (1) LOCKING ON EACH SUPPORT PANEL; (4) NON-LOCKING ON END PANELS (NOTE: IF CASTERS WILL NOT GO IN BY HAND, USE A HAMMER AND A SMALL BLOCK OF WOOD AND TAP GENTLY INTO PLACE.) REF. #6

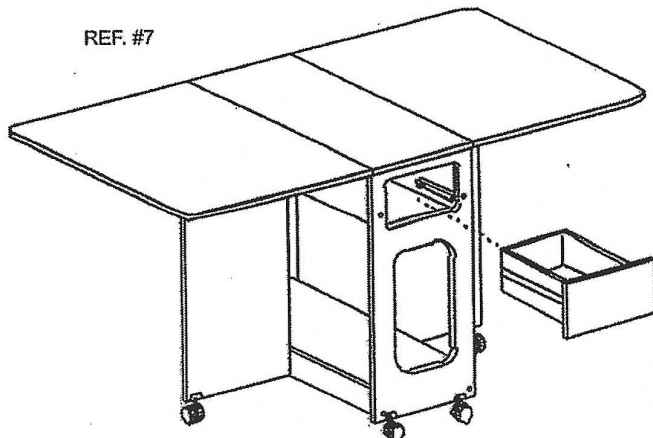
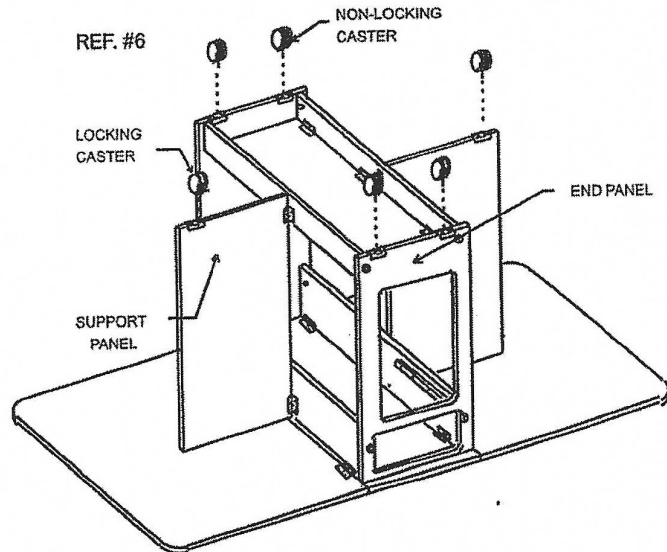

5. CLOSE SUPPORT PANELS AND FOLD DROP LEAFS TO CLOSED POSITION AND SLOWLY FLIP UNIT OVER TO UPRIGHT POSITION. UNFOLD DROP LEAVES AND SUPPORT PANELS AS SHOWN IN REF. #7. INSTALL DRAWER AS SHOWN.

2111B DRAWER ASSEMBLY INSTRUCTIONS.

3/5/2002

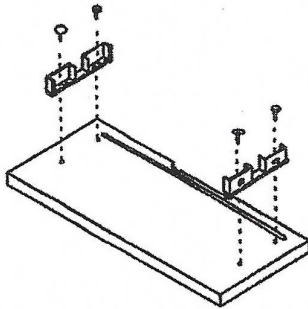

1. INSTALL PLASTIC BRACKETS TO DRAWER FRONT. USING FOUR (4) PAN HEAD ZINC SCREW (P/N 2111B-18-S). NOTE: ALIGN DRAWER BOTTOM GROOVE.

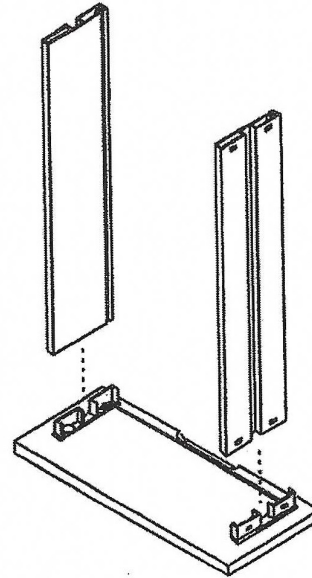

2. INSTALL PLASTIC DRAWER SIDES- NOTE: ALIGN DRAWER BOTTOM GROOVE.

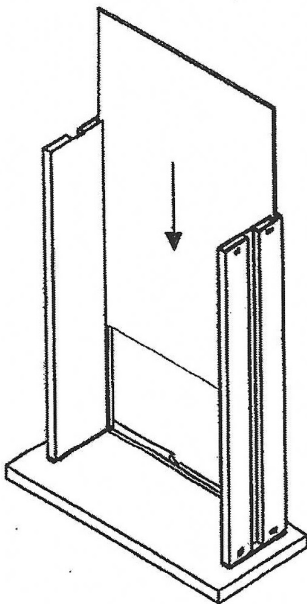

3. SLIDE DRAWER BOTTOM INTO PLACE AS SHOWN.

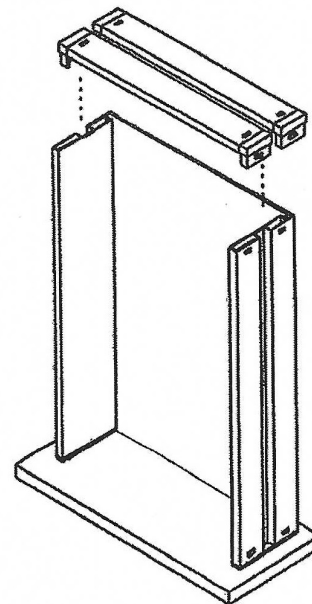

4. INSTALL BACK. NOTE: ALIGN DRAWER BOTTOM GROOVE.

WARNING

Drilling, sawing, sanding or machining wood products generates wood dust, a substance known to the State of California to cause cancer. Avoid inhaling wood dust or use a dust mask or other safeguards for personal protection.

AVERTISSEMENT

Percer, couper, sabler ou usiner des produits du bois génère de la poussière de bois, une substance connue de l'État de la Californie comme étant cancérigène. Évitez de respirer la poussière de bois ou utilisez un masque ou autre équipement de protection personnel.